



**Environmental  
Planning  
Commission**

**Agenda Item Number: 1**  
**Project #: PR-2023-009363**  
**Case #: SI-2023-01635/  
SI-2023-01638**  
**Hearing Date: April 11, 2024**

**Supplemental Staff Report - Remand (to be read in conjunction with the 11/16/23 Staff Report)**

<b>Agent</b>	Consensus Planning
<b>Applicant</b>	City of Albuquerque Parks and Recreation Department/New Mexico United Soccer
<b>Request</b>	<b>Major Amendment of a Master Development Plan/Site Plan for Subdivision</b> <b>Site Plan-EPC</b>
<b>Legal Description</b>	All or a portion of Tracts A-1 through G-1, Plat of Tracts A-1 through H-1, I-1-A & I-2-A, Tract I-A-A, Plat of Tracts A-1 through H-1, I-1A & I-2-A, and a fraction of Lot 2, located in NE ¼ NE ¼ Sec 11, T11N, R3E, a/k/a Tracts F & G, Heirs of Filiberto Gurule Tract
<b>Location</b>	Balloon Fiesta Park, between Paseo del Norte NE and Roy Avenue NE
<b>Size</b>	Approximately 7-acre portion of 367.5 acre site
<b>Zoning</b>	NR-PO-A

**Staff Recommendation**

**APPROVAL of SI-2023-01635, based on the Findings beginning on Page 11 & 19, and subject to the Conditions of Approval, beginning on Page 20.**

**APPROVAL OF SI-2023-01638, based on the Findings beginning on Page 21, and subject to the Conditions of Approval, beginning on Page 29.**

**Silvia Bolivar, PLA, ASLA  
Senior Planner**

**Summary of Analysis**

The request consists of three parts: 1) a Major Amendment to the 2012 Balloon Fiesta Park Master Development Plan (MDP) that would allow for the addition of a Multi-Use Stadium; 2) a Site Plan for Subdivision – the 2012 MDP included a Site Plan for Subdivision that the EPC approved. The Site Plan for Subdivision requires separate approval from the MDP, but the MDP nor the Site Plan for Subdivision cannot be approved without the other; 3) Site Plan - EPC that would facilitate development of the Multi-Use Stadium and additional parking on 7-acres north of the launch field thereby increasing BFP acreage to approximately 367.5 acres.

This case was heard at the November 16, 2023 EPC hearing, was appealed, and the Land Use Hearing Officer remanded the case back to the EPC for a new hearing, including the opportunity for cross examination. The case was re-scheduled for the March 21, 2024 EPC hearing but several requests for a deferral were received from members of the community. Additionally, the applicant requested a deferral. Out of abundance of caution, Staff opted to request the deferral to a special session on April 11, 2024. This decision was made to provide ample time for a study session, intended to refresh both EPC Commissioners and staff on cross-examination procedures. At the time of this writing, letters in support and opposition to the request were received. Staff recommends approval subject to conditions of approval to ensure requirements are met.

***Table of Contents***

I. Overview.....3  
    Update..... 3

II. Background..... 3  
    EPC Hearings .....3  
    Appeals & LUHO Hearing..... 3  
    Remand Instructions .....4

III. Analysis of Applicable Ordinances, Plans, and Policies .....4

IV. Site Plan – EPC ..... 4

V. Neighborhood Concerns ..... 6  
    Request for a Deferral ..... 7  
    Letters of Opposition ..... 7  
    Letters of Support ..... 7

VI. Additional Studies/Investigations ..... 9

VII. Conclusion..... 9

Findings, SI-2023-01635-MA..... 11

Findings, SI-2023-01635-Site Plan for Subdivision.....19

Conditions, SI-2023-01635-MA.....20

Findings, SI-2023-01638-Site Plan – EPC.....21

Conditions, SI-2023-01638-Site Plan.....29

*Attachments*

- 2 LUHO Remand Instructions
- 3 Applicant Information  
    Update to Justification Letter/ Traffic Impact Analysis/ Updated Lighting Analysis
- 4 Re-Notification
- 5 Post-LUHO Facilitated Meeting
- 6 Letters of Support
- 7 Neighborhood Concerns/Letters of Opposition
- 8 Deferral Request
- 9- Site Plan – EPC (Site Plan, Building & Structure Elevations/Contextual Analysis  
    /Renderings/Architectural Details)

**SEPARATE AGENDA ITEMS**

- Agenda\_1b\_PR-2023-009363\_SI-2023-01635\_SI-2023-01638\_BFP MDP Proposed Text Amendments
- Agenda\_1c\_PR-2023-009363\_SI-2023-01635\_SI-2023-01638\_BFP\_MDP\_SPS\_Site Plan-EPC  
    November 16, 2023 Staff Report
- Agenda-1d-AC-23-22-BFP\_Appeal Packet



## ***I. OVERVIEW***

The request comprises three components: 1) A Major Amendment to the 2012 Balloon Fiesta Park Master Development Plan (MDP), enabling the addition of a Multi-Use Stadium; 2) A Site Plan for Subdivision – the 2012 MDP originally included a Site Plan for Subdivision, which was approved by the EPC. This Site Plan for Subdivision necessitates separate approval from the MDP, and both the MDP and Site Plan for Subdivision are interdependent for approval; 3) A Site Plan – EPC that would facilitate the development of the Multi-Use Stadium and additional parking on 7-acres north of the launch field thereby increasing BFP acreage to approximately 367.5 acres.

### ***Update***

The request is now before the EPC because the Land Use Hearing Officer (LUHO) remanded the request to the EPC to be heard *de novo/a new*, due to incomplete notification of seven property owners west of Balloon Fiesta Park. Since the LUHO hearing, the agents (Consensus Planning) for the applicants mailed notification to all property owners within the 100-foot buffer, using both the property owner address and the site address if different from the property owner address. Notifications were sent to all properties along the east side of Edith Boulevard that were outside the buffer, property owner addresses that the appellants believed were required to be notified but were outside the buffer, and other nearby property owner addresses (see attachments).

On March 1<sup>st</sup>, the City Parks and Recreation Department conducted a canvassing operation in the area and placed notification letters at all property sites within the buffer and along the east side of Edith Boulevard. Consensus Planning provided verification to the Planning Department on March 4<sup>th</sup> confirming that all required notifications had been completed.

Consensus Planning also emailed notification of the remanded March 21, 2024 EPC hearing and a facilitated meeting was held on March 4<sup>th</sup> with the two City-recognized neighborhood associations (Wildflower and District 4) as well as the Alameda North Valley, North Edith Corridor, and Maria Diers neighborhood associations (see attachments). The facilitated meeting will be addressed further in the report.

Due to the case being deferred at the March 21, 2024 hearing, on March 27, 2024, Consensus Planning updated the posted signs to reflect the rescheduled special hearing date of April 11, 2024, after the case was deferred (see attachments).

## ***II. BACKGROUND***

### ***EPC Hearings***

The request was heard during the Environmental Planning Commission (EPC) hearing on November 16, 2023, received approval based on 22 findings for the Major Amendment/Site Plan for Subdivision and 18 findings for the new Site Plan-EPC.

The case was re-scheduled for the March 21, 2024 EPC hearing but several requests for a deferral were received from members of the community. Additionally, the applicant requested a deferral. Out of abundance of caution, Staff opted to request the deferral to a special session on April 11, 2024. This decision was made to provide ample time for a study session, intended to refresh both EPC Commissioners and staff on cross-examination procedures.

### ***Appeals & LUHO Hearing***

An appeal of the EPC's decision was filed by Pat Houser and other concerned parties (AC-23-22). The appellants cited improper mailed notice, errors in the decision-making process, and insufficient consideration of neighborhood concerns.

At the February 16, 2024 (LUHO) hearing, the appellants stipulated that at least nine property owners meeting the proximity criteria outlined in § 6-4(K)(3)(c) were not notified. Despite the appellant's desire to address the merits of their appeal during the hearing, the LUHO deemed it unnecessary, stating that a *de novo* remand hearing was required. The LUHO also reasoned that assessing the appeal's merits could prejudice a party in the subsequent remanded hearing before the EPC (see attachments).

### ***Remand Instructions***

The LUHO remanded the case to the EPC with specific directives: The remand must be *de novo*, reheard anew.

Notice shall be fully accomplished as required under the IDO: in areas in which the edge of that 100-foot buffer falls within any public right-of-way; adjacent properties will be included in the notice.

The new hearing must also satisfy *State ex rel. Battershell v. City of Albuquerque*, 1989-NMCA-045, including the provision which allows for the opportunity for testimony and cross-examination.

### ***EPC Role***

Please refer to page 8 of the November 16, 2023 Staff Report.

### ***Context***

Please refer to pages 9-10 of the November 16, 2023 Staff Report.

### ***History***

Please refer to pages 10-11 of the November 16, 2023 Staff Report.

### ***Transportation System, Comprehensive Plan Designations, Overlay Zones, Trails/Bikeways, Transit, and Public Facilities/Community Services***

Please refer to pages 11-13 of the November 16, 2023 Staff Report.

## ***III. ANALYSIS of APPLICABLE ORDINANCES, PLANS, AND POLICIES***

### ***Integrated Development Ordinance (IDO)***

Please refer to pages 13-19 of the November 16, 2023 Staff Report for the original policy analysis.

## ***IV. SITE PLAN – EPC***

### ***A. Site Plan Layout/Configuration***

This proposed site plan is for an approximately 7-acre portion of Balloon Fiesta Park (BFP) which would facilitate development of a 225' x 360' Outdoor Multi-Use Stadium, along with an associated

parking facility, and site improvements. The footprint of the multi-use stadium structure is approximately 185,000 square feet, stadium capacity will be 11,000 (9,600 seating and drink rail capacity/1400 berm seating and standing room capacity).

The proposed stadium is located on the northeastern side of Balloon Fiesta Park, to the south of Balloon Fiesta Parkway. To the north of the stadium, is the East Parking Lot, and there is a grassy berm picnic area located to the east of the proposed parking lot. Adjacent to the stadium's east side, there is a grass-bermed seating area featuring sloped concrete paving. New landscaping surrounds the Stadium and is located throughout the parking lot.

In light of concerns raised by the local community in multiple neighborhood gatherings and at the EPC hearing on November 16, 2023, the applicant made revisions to the site plan and building elevations. Specifically, the stadium has been relocated 18 feet eastward and 10 feet southward, now situated deeper within the escarpment. This relocation has facilitated the creation of an extra row of parking. Additionally, the updated site plan incorporates a redesigned roof and an ADA-compliant ramp along Gondola Gulch.

#### ***Building Design & Architecture***

The applicant has submitted a revised Context Analysis Drawing (Sheet 12) and revised Building and Structure Elevations (Sheet 9 & 10) (see attachments).

The revised drawings and updated memorandum indicate the following:

#### ***Reduced Structure Height:***

The stadium has been downsized to a 3-4 story structure with a maximum height of 65 feet above pitch level (relative to the 5058' contour). The reduction in height will allow for the stadium to blend in better with the surrounding escarpment.

#### ***Enhanced Landscape Features:***

More earthen berms will be incorporated at the base of the elevation, increasing the ability to buffer sound while offering more opportunities for passive park recreation.

#### ***Expanded West Side Roof:***

The roof overhang on the west side has been expanded to cover the entire seating bowl. This change aims to improve sound control within the stadium. Additionally, the broader roof will enhance the potential for installing a distributed sound system.

#### ***Adjusted Building Footprint:***

As per the memorandum providing updates, the stadium has been relocated 18 feet eastward and 10 feet southward, now situated deeper within the escarpment. This relocation has facilitated the creation of an extra row of parking. Additionally, the updated site plan incorporates a redesigned roof and an ADA-compliant ramp along Gondola Gulch.

Based on the site plan revision, the applicant will be required to update the following: Overall Landscape Plan, Landscape Plan – North & South, Overall Conceptual Utility Plan, Overall Grading & Drainage Plan, Grading & Drainage – North & South. In addition, the applicant will be required to update the Site Plan for Subdivision 2023 Amendments (Sheets 1-4). A condition of approval will be added to guarantee compliance with requirements and offer clarification as needed.

*Cross Sections*

The project architect has provided a cross-sectional view depicting the sightline from residences along Edith to the stadium area. The cross-section shows that the stadium will not be seen from the houses along Edith. However, the second-floor levels of some residences will have visibility of the stadium without obstructing views of the Sandia Mountains.

*Lighting/Architectural Details*

Update:

The east light pole height at the stadium has been reduced by 10 feet, from an initial 100 feet down to a maximum of 90 feet above the field. This change was implemented in order to address lighting-related concerns by nearby residents.

**V. NEIGHBORHOOD CONCERNS**

*Neighborhood/Public*

Notification requirements are found in 14-16-6, in the Procedures Table 6-1-1 and are further explained in 14-16-6-4(K), Public Notice. Following the LUHO hearing, agents representing the applicants sent notifications to all property owners residing within the 100-foot buffer zone, utilizing both property owner addresses and, if different, the site address. Notifications were distributed to properties situated along the east side of Edith Boulevard that fell outside the buffer, property owner addresses identified by the appellants as necessitating notification but located outside the buffer, and other neighboring property addresses.

On March 1<sup>st</sup>, the City Parks and Recreation Department carried out a canvassing operation, delivering notification letters to all property sites within the buffer and along the east side of Edith Boulevard. Consensus Planning provided confirmation to the Planning Department on March 4<sup>th</sup>, attesting to the completion of all requisite notifications.

Furthermore, Consensus Planning forwarded notification via email regarding the remanded March 21, 2024 EPC hearing. A facilitated meeting was held on March 4, 2024 with the participation of the two City-recognized neighborhood associations (Wildflower and District 4), as well as the Alameda North Valley, North Edith Corridor, and Maria Diers Neighborhood Associations.

Concerns – Neighborhood Associations/Residents Regarding Facilitated Meeting

Staff received multiple emails from neighborhood associations and residents expressing several concerns about the procedure and communication related to the facilitated meeting conducted on March 4, 2024 (see attachments). It is important to note that the remand instructions from the LUHO did not include provisions for a facilitated meeting.

Concerns include:

Short Notice: According to the commenters, the notice for the meeting appeared to be inadequate, providing less than 3 business days' notice, which may not allow concerned individuals and property owners enough time to plan effectively.

Location: The suggested locations for the meetings by residents, such as the City Council chambers or the County Chambers, were deemed neutral and appropriate to hold the facilitated meeting.

Accessibility: Concerns were expressed regarding the accessibility of the meeting, particularly for individuals who may not have internet access or who may have had prior commitments arranged before the short notice of the meeting.

Time Limit for Comments/Impact on Nearby Residents: The residents expressed concern that the limitation of 2 minutes is inadequate for discussing impacts that may be caused by the proposed multi-use outdoor stadium.

Concerns arose about the North Valley Coalition not receiving notification on behalf of the North Edith Corridor Association (NEC) regarding the facilitated meeting. The Office of Neighborhood Coordination (ONC) clarified that the omission occurred because NEC is not recognized within the City of Albuquerque.

#### Request for a Deferral

On March 8, 2024, Staff received an email from neighboring residents expressing their opposition to the stadium. They formally asked for the rescheduling of the EPC hearing from the March 2024 agenda to the April 2024 agenda, citing the need for sufficient preparation time and compliance with due process regulations by the applicants.

On March 21, 2024, Staff was contacted via email by members of the North Valley community and their neighborhood association, who requested a 90-day deferral. Additionally, concerns were raised regarding opposition members who attempted to comment during the discussion of the appeal at the March 21, 2024 hearing, despite the agenda item being closed for discussion, thus preventing any public comments. Staff replied to the received emails, assuring that the public would have an opportunity to express their concerns during the April 11, 2024 hearing, and directed that requests for the 90-day deferral should be addressed to the Chair.

#### Letters of Opposition

On March 8, 2024, an email was received from a local resident expressing opposition to the soccer stadium. The resident cited numerous concerns, notably regarding the potential adverse effects on the neighborhood and its rural ambience. Key concerns include the potential interference with geese flight paths due to the proposed stadium location, as well as noise and light pollution from soccer games, concerts, and other events. Moreover, worries about traffic congestion, threats to the rural lifestyle, and perceived lack of community engagement and meaningful dialogue with the applicant were also highlighted.

The majority of the emails express concern of increased traffic and no outlined measures for traffic management by New Mexico United, nor penalties for non-compliance or recourse for affected neighbors, existing issues of event attendees parking on adjoining streets and trespassing through private property during festivals, without adequate policing or traffic control, and lack of specificity in the team's promises regarding noise mitigation measures and impact of stadium lights of neighbors.

Overall, the concerns/opposition encompass traffic management, noise and light pollution, and safety issues arising from potential events at the proposed stadium, with a focus on preserving the quality of life in the area.

#### Letters of Support

Numerous emails were received endorsing the application (see attachments). While acknowledging valid concerns regarding traffic, it is argued that the impact of a Saturday night United match would be minimal compared to the massive crowds exceeding 800,000 visitors during Balloon Fiesta's ten-day duration. Most matches occur on weekend nights, so typical commute times for nearby residents would not be significantly affected. Moreover, the increased foot traffic would benefit local businesses along Alameda Boulevard and surrounding areas.

Supportive letters highlight favorable light and noise reports, suggesting that the city could embark on an innovative and bold endeavor by transforming an unused corner of the park into a revenue-generating venue. Such development would provide entertainment to citizens and offer New Mexico United a permanent home.

The Board of Directors of the Albuquerque Hispano Chamber expressed wholehearted support for the proposed stadium, seeing it as extending beyond soccer and enhancing New Mexico's profile while promoting youth sports, economic development, and tourism. They note that state-funded infrastructure improvements will enrich the park experience for all attendees, including those at the Albuquerque International Balloon Fiesta (AIBF). Furthermore, New Mexico United has pledged to ensure no interference with Balloon Fiesta programming, and the stadium's location under existing power lines will ensure no impact on fly zones.

#### Facilitated Meeting – March 4, 2024

This was the second facilitated meeting held regarding the application for the proposed multi-use outdoor stadium that requires changes in the language of the BFP Master Development Plan/Site Plan for Subdivision/Site Plan-EPC (see attachments).

Attendees included many residents of nearby neighborhoods who are overwhelmingly in opposition to the proposed stadium. They have cited issues regarding noise, lighting, traffic, community disruption, impact on the area's rural character, decreased property values, as well as the intensity of the proposed uses at the stadium.

Other issues that were discussed during the meeting included lease agreement concerns and inquiries regarding the business plan which are not the purview of the Environmental Planning Commission.

An email was received from a member of the community containing questions meant to be addressed during the facilitated meeting, yet those questions were not discussed.

## **VI. ADDITIONAL STUDIES/INVESTIGATIONS**

During the November 16, 2023 EPC Hearing, the traffic impact study report had not been included in the staff report although the agent discussed summary findings. Subsequently, the applicant submitted the report (see attachments), and a summary is outlined below.

### Traffic Impact Study

Overall, the proposed United Stadium is concluded to have a smaller impact compared to Balloon Fiesta event traffic. For the average stadium event with 60% percent of seating capacity filled, anticipated ingress and egress traffic result in traffic volumes when combined with non-event traffic to volumes comparable to the Alameda Blvd corridor operations under regular weekday rush hour traffic. For maximum attendance events, the combination of normal traffic with event traffic results in volumes approximating a single hour's worth of Balloon Fiesta demand. Regular United games would likely require about the same level and intensity as those implemented today for United games held at the Isotopes Park. Maximum attendance games are anticipated to require a level of traffic control closer to that seen during the Balloon Fiesta in scope but less intensive with regard to the implementation of traffic control devices (see attachments)

### New Mexico United Stadium Noise Study – March 6, 2024 Update

An update memorandum was provided in an effort to enhance the design and validate its suitability for minimizing sound migration from the stadium while complying with required ordinances (see attachment).

## **VII. CONCLUSION**

The request comprises three components: 1) A Major Amendment to the 2012 Balloon Fiesta Park Master Development Plan (MDP), enabling the addition of a Multi-Use Stadium; 2) A Site Plan for Subdivision – the 2012 MDP originally included a Site Plan for Subdivision, which was approved by the EPC. This Site Plan for Subdivision necessitates separate approval from the MDP, and both the MDP and Site Plan for Subdivision are interdependent for approval; 3) A Site Plan – EPC designated to facilitate the development of the Multi-Use Stadium and additional parking on 7-acres north of the launch field thereby increasing BFP acreage to approximately 367.5 acres.

The request was heard during the Environmental Planning Commission (EPC) hearing on November 16, 2023, received approval based on 22 findings for the Major Amendment/Site Plan for Subdivision and 18 findings for the new Site Plan-EPC.

An appeal of the EPC's decision was filed by Pat Houser and other concerned parties (AC-23-22). The appellants cited improper mailed notice, errors in the decision-making process, and insufficient consideration of neighborhood concerns.

At the February 16, 2024 Land Use Hearing Officer (LUHO) hearing, the appellants stipulated that at least nine property owners meeting the proximity criteria outlined in § 6-4(K)(3)(c) were not notified. Despite the appellant's desire to address the merits of their appeal during the hearing, the LUHO deemed it unnecessary, stating that a *de novo* remand hearing was required. The LUHO also reasoned that assessing the appeal's merits could prejudice a party in the subsequent remanded hearing before the EPC.

In response to neighborhood concerns expressed during several neighborhood meetings and, during the November 16, 2023 EPC hearing, the applicant revised the building elevations and will be updating the site plan.

The stadium has been downsized to a 3-4 story structure with a maximum height of 65 feet above pitch level (relative to the 5058' contour). The reduction in height will allow for the stadium to blend in better with the surrounding escarpment.

More earthen berms will be incorporated at the base of the elevation, increasing the ability to buffer sound while offering more opportunities for passive park recreation.

The roof overhang on the west side has been expanded to cover the entire seating bowl. This change aims to improve sound control within the stadium. Additionally, the broader roof will enhance the potential for installing a distributed sound system.

As per the memorandum providing updates, the stadium's building footprint has been shifted approximately 16 to 18 feet further east and 5 to 10 feet to the south. The adjustment will increase the embedment of the stadium into the escarpment, potentially improving the overall suitability and integration with the surrounding landscape.

The project architect has provided a cross-sectional view depicting the sightline from residences along Edith to the stadium area. The cross-section shows that the stadium will not be seen from the houses along Edith. However, the second-floor levels of some residences will have visibility of the stadium without obstructing views of the Sandia Mountains.

The east light poles' height at the stadium has been reduced by 10 feet, from an initial 100 feet down to a maximum of 90 feet above the field. This change was implemented in order to address lighting-related concerns by nearby residents.

The subject site is zoned NR-PO-A (Non-residential – Parks & Open Space, City-Owned or Managed Park). It is located in an Area of Consistency and within the North I-25 Character Protection Overlay Zone (CPO-10).

The request is generally consistent with applicable Comprehensive Plan goals and Policies. Staff has crafted conditions of approval to create compliance with applicable IDO standards and to provide internal consistency in the Balloon Fiesta Master Development Plan, and provide clarity for the future.

On March 8, 2024, staff received an email from neighboring residents expressing their opposition to the stadium. They formally asked for the rescheduling of the EPC hearing from the March 2024 agenda to the April 2024 agenda. As of this writing, Staff has received several letters of support and opposition to the request (see attachments).

Staff recommends approval subject to Conditions #1 & #2 on Page 20 of this report.



---

***FINDINGS – PR-2023-009363, SI-2023-01635, Major Amendment to the Balloon Fiesta Park Master Development Plan (MDP)/Site Plan for Subdivision - March 21, 2024***

1. The request is for text amendments to the Balloon Fiesta Park (BFP) Master Development Plan (MDP) enabling the addition of a Multi-Use Stadium and a Site Plan for Subdivision. The 2012 MDP originally included a Site Plan for Subdivision, which was approved by the EPC. This Site Plan for Subdivision necessitates separate approval from the MDP, and both the MDP and Site Plan for Subdivision are interdependent for approval. The site is legally described as all or a portion of Tracts A-1 through G-1, Plat of Tracts A-1 through H-1, I-1-A & I-2-A, Tract I-A-A, Plat of Tracts A-1 through H-1, I-1A & I-2-A, and a fraction of Lot 2, located in NE ¼ NE ¼ Sec 11, T11N, R3E, a/k/a Tracts F & G, Heirs of Filiberto Gurule Tract, between Paseo del Norte NE and Roy Avenue NE (the “subject site”).
2. The subject site is zoned NR-PO-A (Non-Residential Park and Open Space, city owned or managed Park Zone District), a zoning designation received upon adoption of the IDO. The subject site was formerly zoned SU-2 for Balloon Park Museum & Related Uses.
3. The EPC is hearing the request because, as per the Integrated Development Ordinance (IDO), all pre-IDO MDS on City-owned properties must follow the amendment process identified in IDO 14-16-6-4(Z)(3).
4. The request was heard and approved during the November 16, 2023 EPC hearing. Aggrieved parties appealed the decision citing improper mailed notice, errors in the decision-making process, and insufficient consideration of neighborhood concerns.
5. On February 16, 2024, the Land Use Hearing Officer (LUHO) remanded the case back to the EPC for a new hearing due to improper notification. The remand instructions state: The remand must be de novo, reheard anew.

“Notice shall be fully accomplished as required under the IDO; in areas in which the edge of that 100-foot buffer falls within any public right-of-way, adjacent properties will be included in the notice”.

The new hearing must also satisfy State ex rel. Battershell v. City of Albuquerque, 1989-NMCA-045, including the provision which allows for the opportunity for testimony and cross-examination.

6. The City’s Parks and Recreation Department holds the responsibility of overseeing the development as well as the management and operations at Balloon Fiesta Park, as defined by the Master Development Plan (MDP). The MDP, originally approved by City Council in 1998, serves as the primary governing document for Balloon Fiesta Park.
7. The applicant wishes amend the Balloon Fiesta MDP: to 1) eliminate the language that currently prohibits the use of an Outdoor Multi-Use Stadium; 2) Modifying the MDP and the associated Site Plan for Subdivision to include the Outdoor Multi-Use Stadium in the area where a 5-6 multi-story parking structure was initially permitted under the approved MDP; 3) Modifying the light standards as outlined in Section 6: Design Performance Standards to allow for stadium lighting; 4) Replacing the Northeast Outdoor recreation Area with surface parking; 5) introducing an

additional adjacent tract for Balloon Fiesta's parking needs, facilitating the creation of 750 more parking spaces and expanding the park's total acreage from 358 acres to 367.5 acres

8. Upon receiving approval of this request, the applicant would be required to update the Master Plan layout with all previous administrative amendments to create consistency and reflect the current and future BFP MDP programming
9. The subject site is located in an Area of Consistency and is in the North I-25 Community Planning Area (CPA).
10. The Albuquerque/Bernalillo County Comprehensive Plan, the Balloon Fiesta Park Master Development Plan, and the Integrated Development Ordinance (IDO) are incorporated herein by reference and made part of the record for all purposes.
11. The request is consistent with the following Comprehensive Plan Goal and Policies regarding Character from Chapter 4: Community Identity.

A. Goal 4.1 Character: Enhance, protect, and preserve distinct communities

The subject site is located in an Area of Consistency, and the proposed request is consistent with the goal of enhancing, protecting, and preserving the distinct character of the community. This consistency is achieved by establishing the Multi-Use Stadium within the existing Balloon Fiesta Park, in line with the objectives outlined in the Master Development Plan. Balloon Fiesta Park is a vital part of the North I-25 community, and the introduction of a new stadium, along with associated infrastructure improvements, aims to enhance, protect, and preserve this distinct community by offering an additional use/amenity that caters to the preferences of both local and statewide residents.

B. Policy 4.1.1 Distinct Communities: Encourage quality development that is consistent with the distinct character of communities.

The request would facilitate quality development that is consistent with the distinct character of the community because the proposed site plan is required to follow MDP design standards. The stadium's design, as depicted in the Site Plan, exemplifies high-quality development that matches the unique character of the North I-25 community. The layout adheres to the Balloon Fiesta Park Master Development Plan initially created in 1998 and updated in 2012. The amendments to the MDP will outline the desired development quality for this regional park facility that hosts the state's signature event while providing a range of indoor and outdoor recreational and cultural activities for residents, statewide residents, and visitors.

C. Policy 4.1.2 Identity and Design: Protect the identity and cohesiveness of neighborhoods by ensuring the appropriate scale and location of development, mix of uses, and character of building design.

The request would generally protect the identity and cohesiveness of neighborhoods nearby by ensuring the appropriate scale and location of development, mix of uses, and character of building design within the existing Balloon Fiesta Park. The scale and intensity of use shown on the Site Plan, Landscape Plan, and building elevations have been designed to reflect and improve existing site conditions while implementing the vision of the MDP. The stadium's

height is less than the maximum height of 26 feet above the east property line/escarpment allowed by the MDP, which will further protect the identity and cohesiveness of nearby neighborhoods. While the Balloon Museum reaches a height of 75 feet, the proposed stadium, like the Golf Training Center and Sid Cutter Pilot's Pavilion, was designed to harmonize with the area's character.

- D. Policy 4.1.3 Placemaking: Protect and enhance special places in the built environment that contribute to distinct identity and sense of place.

The request is consistent with this policy because Balloon Fiesta Park's unique status within the built environment contributes to the distinct identity and sense of place in the North I-25 area. The proposed amendments will allow for the development of the stadium, that has been designed to preserve the natural and man-made features of the park while enhancing the east escarpment and the northern side of Gondola Gulch. The area will further be protected and enhanced because the stadium's development will help address concerns related to the Nazareth Landfill by implementing measures to mitigate landfill gasses in coordination with Environmental Health.

12. The request is consistent with the following Comprehensive Plan Goals and Policies regarding land use and Areas of Consistency from Chapter 5: Land Use.

- A. Goal 5.2 Complete Communities: Foster communities where residents can live, work, earn, shop, and play together. r and needs.

The request is consistent with this Goal because the Site Plan and Major Amendment are designed to foster a community where residents can live, work, learn, shop, and socialize together. The introduction of the stadium to Balloon Fiesta Park will amplify opportunities for social engagement and leisure, all while generating new employment possibilities for residents. The stadium's construction and ongoing functions will provide job openings for community members, encompassing roles for construction workers, stadium personnel, and event-related services such as hospitality and concessions.

- B. Policy 5.2.1 – Land Uses: Create healthy, sustainable, and distinct communities with a mix of uses that are conveniently accessible from surrounding neighborhoods.

The request would contribute to a healthy, sustainable, and distinct community in the North I-25 CPA and its' neighborhoods because the Site Plan and Major Amendment would allow for additional use at BFP, making it easily accessible to nearby neighborhoods. The park is well connected to the City's trail network including the North Diversion Channel. In addition, the subject site is accessible to pedestrians, bicyclists, and transit users nearby via internal trails, sidewalks and a bike route along Alameda Boulevard.

- C. Policy 5.6.3 – Areas of Consistency: Protect and enhance the character of existing single-family neighborhoods, areas outside of Centers and Corridors, parks, and Major Public Open Space.

The request would generally enhance the existing park and protect the character of neighborhoods located in an Area of Consistency by thoughtfully siting the stadium within the park and avoiding the placement of incompatible uses.

13. The request is consistent with the following Comprehensive Plan Goal and Policies regarding Development Quality and Context from Chapter 7: Urban Design.

- A. Goal 7.3 – Sense of Place: Reinforce sense of place through context-sensitive design of development and streetscapes.

The proposed Site Plan, Landscape Plan, and building elevations, as outlined by the Site Plan – EPC, are guided by the MDP and are consistent with this Goal. The placement of the stadium has been carefully considered and is designed to seamlessly integrate within the escarpment while remaining below the high-voltage power lines. The MDP recognizes the advantages and challenges posed by the escarpment at Balloon Fiesta Park, including erosion issues affecting the park’s functionality. Balloon Fiesta Park is an integral part of the North I-25 community, and the introduction of the new stadium, along with associated infrastructure improvements, is focused on the development and streetscape design that harmonizes with the local context.

- B. Policy 7.3.5 – Development Quality: Encourage innovative and high-quality design in all development.

The Site Plan, building elevations, and stadium placement are consistent with this policy because the design is innovative and has high-quality features consistent with the proposed major amendment of the MDP. The stadium’s location has been carefully chosen and is nestled within the escarpment and positioned beneath the high-voltage lines, effectively incorporating the escarpment as a prominent architectural element. The design includes sloped walkways, grassy berm seating, and picnic areas.

- C. Goal 7.5 – Context Sensitive Site Design: Design sites, buildings, and landscape elements to respond to the high desert environment.

The building and landscape plans are consistent with this policy because they are specifically tailored to address the challenges of the high desert climate by incorporating shade features, canopies, and shade trees.

- D. Policy 7.5.1 – Landscape Design: Encourage landscape treatments that are consistent with the high desert climate to enhance our sense of place.

The Landscape Plan, a fundamental element of the Site Plan-EPC and in compliance with the MDP’s recommendations, is consistent with this policy because the designed landscape and plant selection are specifically tailored to thrive in Albuquerque’s high desert climate. The plant palette consists of trees, shrubs, groundcovers, and ornamental plants suited for this environment, contributing to the distinctive ambiance of Balloon Fiesta Park.

14. The request is consistent with the following Comprehensive Plan Goal and Policies regarding Facilities, Access & Universal Design from Chapter 10: Parks & Open Space.

- A. Policy 10.1 – Facilities & Access: Provide parks, Open Space, and recreation facilities that meet the needs of all residents and use natural resources responsibly.

The Site Plan and Major Amendment to the MDP are consistent with this Goal because they facilitate the development of a new section within Balloon Fiesta Park to cater to the needs of all residents while responsibly utilizing natural resources. The stadium and its associated improvements are designed for use by people of all ages and occupy an underutilized portion of the Park initially designated for a multi-story parking structure. The Major Amendment will allow for an increase in parking capacity compared to the original MDP as land was acquired to the north for parking purposes, with the Site Plan showcasing a more efficient parking layout in this area.

- B. Policy 10.1.2 – Universal Design: Plan, design, program and maintain parks, Open Space, and recreation facilities for use by people of all age groups and physical abilities.

The Site Plan and Major Amendment to the MDP are consistent with this policy because the stadium and its surrounding improvements have been designed to accommodate to residents of all ages and physical abilities. The Site Plan also features improvements to the Gondola Gulch and the slope, improving accessibility for both pedestrians and vehicles within the Park. The project includes permanent restrooms that comply with the Americans with Disabilities Act (ADA) standards, ensuring accessibility for all visitors. Furthermore, the parking area to the north has been thoughtfully designed to include ADA, electric vehicle (EV), and motorcycle parking spaces, thereby increasing access and usability for people of all ages and physical abilities.

- C. Goal 10.2 – Parks: Provide opportunities for outdoor education, recreation, and cultural activities that meet community needs, enhance quality of life, and promote community involvement for all residents.

The request is consistent with this goal because the Site Plan and MDP Amendment will facilitate the expansion of outdoor activities at Balloon Fiesta Park. While the Stadium's primary purpose will be to host the New Mexico United soccer games (anticipated 17 annual home games), it is also designed to accommodate a diverse array of activities, including music events, food festivals, and cultural gatherings, all promoting community involvement. The Stadium's design is adaptable and will cater to various functions at Balloon Fiesta Park.

- D. Policy 10.2.1 – Park Types: Plan and implement a system of parks to meet a range of needs at different scales, including small neighborhood parks, community parks, active parks, regional parks, and linear parks.

The request is consistent with this policy because it will allow the City to improve its park system by adding more recreational amenities at Balloon Fiesta Park. The MDP Amendment will increase the park's size from 358 to 367.5 acres, solidifying its role as a primary regional park facility. The building and site will incorporate ADA design standards to serve the needs of persons of various ages and physical abilities.

- E. Goal 10.4 – Coordination: Coordinate across disciplines, jurisdictions, and geographies to leverage limited resources, maximize efficiencies, and best serve the public's need for parks and recreation facilities.

The Site Plan and Major Amendment to the MDP are consistent with this Goal because they will efficiently utilize constrained resources to bolster the continued growth of Balloon Fiesta Park and meet the community's need for parks and recreational amenities. A state-funded

capital outlay of \$13.5 million has been allocated to address much-needed improvements in infrastructure, encompassing electrical, water, sewer, and telecommunications systems and networks within Balloon Fiesta Park. Additionally, private investments are designated for the construction of the Stadium.

- F. Policy 10.4.3 – Co-located Facilities: Maximize opportunities for multi-functional, co-located, and joint use of compatible parks, Open Space, trails, and recreation facilities to best leverage public investment.

State funds have been allocated for capital outlay that will extend and improve the infrastructure at Balloon Fiesta Park to attract significant private investments to support the construction of the Stadium. The request is consistent with this policy because the Site Plan will maximize the opportunities for a multi-functional park that enhances both passive/active recreation and community events.

15. The request is consistent with the following Comprehensive Plan Goal and Policy from Chapter 12: Infrastructure, Community Facilities & Services

- A. Goal 12.2 – Community Facilities: Provide communities facilities that have convenient access and a wide range of programs for residents from all cultural, age, geographical, and educational groups to enhance quality of life and promote community involvement.

The Site Plan and Major Amendment to the MDP are consistent with this goal because Balloon Fiesta Park benefits from accessible entry via I-25 through Balloon Fiesta Parkway. The proposed stadium, if the Major Amendment to the MDP is approved, will expand the existing array of programs and amenities, catering to a diverse audience of local and statewide residents, encompassing individuals of all ages, cultures, and educational backgrounds.

- B. Policy 12.2.3 – New Facilities: Site new facilities in areas with excellent access to provide services to underserved and developing areas.

The request is consistent with this policy because introducing a new facility at Balloon Fiesta Park, will leverage its excellent accessibility via Interstate 25 and Balloon Fiesta Parkway. Balloon Fiesta Park is designed to cater to a substantial number of visitors, and its location offers access to an area that is comparatively underutilized and underserved.

16. The request meets the Site Plan-EPC Review & Decision Criteria in IDO Section 14-16-6-6(J)(3) as follows:

- A. 14-16-6-6(J)(3)(a) As demonstrated by the policy analysis, the request is consistent with applicable Comprehensive Goals and Policies.
- B. 14-16-6-6(J)(3)(b) Before the adoption of the IDO, the subject site was zoned SU-2 for Balloon Park Museum & Related Uses. The subject site was never zoned NR-SU or PD. The existing zoning is under the jurisdiction of the established Master Development Plan (MDP), which details the regulations and protocols for proposed development. The MDP encompasses the guidelines for the review and approval process by the EPC, specifically for structures exceeding 10,000 square feet.

The existing language within the MDP explicitly prohibits the establishment of an Outdoor Sports Stadium at Balloon Fiesta Park. The Applicants are seeking a modification to the MDP permit development of an Outdoor Multi-Use Stadium. If the revised master plan is approved, all its terms and conditions will be adhered to.

- C. 14-16-6-6(J)(3)(c) The subject site must comply with all applicable provisions of the IDO, the DPM, and other adopted City regulations, including the Balloon Fiesta Park Master Plan.
  - D. 14-16-6-6(J)(3)(d) The City's existing infrastructure and public improvements have adequate capacity to support the Stadium project, with the exception of the electrical, water, and sewer systems. A state-funded capital outlay of \$13.5 million has been allocated to address much-needed improvements in infrastructure, encompassing electrical, water, sewer, and telecommunications systems and networks within Balloon Fiesta Park
  - E. 14-16-6-6(J)(3)(e) The future, proposed development would be required to comply with the decisions made by the EPC. The EPC's conditions of approval would improve compliance with the IDO, which contains regulations to mitigate site plan impacts to surrounding areas.
  - F. 14-16-6-6(J)(3)(f) The subject property is within the Balloon Fiesta Park Master Development Plan and the Site Plan meets relevant standards in the Balloon Fiesta Park Master Development plan and applicable standards in the NR-PO-A zone.
  - G. 14-16-6-6(J)(3)(g) A portion of the subject site falls within the Railroad and Spur Area, the proposed Stadium is not within 1,320 feet of a Residential zone district or a lot containing a residential use in any Mixed-Use zone District. In addition, the Stadium is not within 660 feet of another use as described in Subsection 5-2(E)(1)(c).
17. Following the LUHO hearing, agents representing the applicants sent notifications to all property owners residing within the 100-foot buffer zone, utilizing both property owner addresses and, if different, the site address. Notifications were distributed to properties situated along the east side of Edith Boulevard that fell outside the buffer, property owner addresses identified by the appellants as necessitating notification but located outside the buffer, and other neighboring property addresses.
- On March 1<sup>st</sup>, the City Parks and Recreation Department carried out a canvassing operation, delivering notification letters to all property sites within the buffer along the east side of Edith Boulevard. Consensus Planning provided confirmation to the Planning Department on March 4<sup>th</sup>, attesting to the completion of all requisite notification.
- Furthermore, Consensus Planning forwarded notification via email regarding the remanded March 21, 2024 EPC hearing. A facilitated meeting was held on March 4, 2024 with the participation of the two City-recognized neighborhood associations (Wildflower and District 4), as well as the Alameda North Valley, North Edith Corridor, and Maria Diers Neighborhood Associations.
18. The A facilitated meeting was held on September 9, 2023 with the affected Neighborhood Associations. The community raised various issues, including heightened traffic, noise and lighting, funding concerns, and reservations about the pre-application meeting notification. These concerns and questions were duly acknowledged and addressed. Although a number of speakers, expressed their enthusiasm for the stadium, there were no explicit opposing comments.
19. On October 22, 2023, a meeting took place with three Project Team members in attendance, namely Matt Proctor from the Improve Group, and Ron Patel and David Wiese-Carl from NM

United. This meeting was organized by residents of the North Alameda neighborhood and included representatives from the Wildflower neighborhood and other nearby areas. Approximately 30 people attended the meeting.

20. On November 2, 2023, an additional meeting was held with the Wildflower Neighborhood Association to discuss the proposed major amendment to the proposed multi-use stadium. During the meeting, members of the project team presented information related to the proposed developments including how the stadium's design has considered mitigating noise and light issues and information was shared about noise, sound, and traffic studies. The meeting included a question-and-answer period where attendees had the opportunity to ask questions and seek clarification on the presented information.

Overall, the meeting served as a platform for the Wildflower Neighborhood Association to engage with the Project Team, understand the proposed development, and express their concerns and inquiries regarding the Balloon Fiesta Park Master Development Plan Amendment and multi-use stadium plans.

21. Additional meetings following the submission of the application took place on multiple occasions during the planning process, involving the Alameda North Valley NA, Wildflower NA, Maria Diers NA, and the North Edith Corridor Association. On November 13, 2023 a meeting was held with industry representatives to provide them an opportunity to discuss the proposed project.
22. On March 4, 2024 a second facilitated meeting was held regarding the application for the proposed multi-use outdoor stadium that requires changes in the language of the BFP Master Development Plan/Site Plan for Subdivision/Site Plan-EPC. Attendees included many residents of nearby neighborhoods who are overwhelmingly in opposition to the proposed stadium. They have cited issues regarding noise, lighting, traffic, community disruption, impact on the area's rural character, decreased property values, as well as the intensity of the proposed uses at the stadium.

Other issues were discussed including the lease agreement concerns and inquiries regarding the business plan which are not the purview of the Environmental Planning Commission. In addition, an email was received from a member of the community containing questions meant to be addressed during the facilitated meeting, yet those questions were not discussed.

23. An email was received from a member of the community containing questions meant to be addressed during the facilitated meeting, yet those questions were not discussed.
24. On March 8, 2024, staff received an email from neighboring residents expressing their opposition to the stadium. They formally asked for the rescheduling of the EPC hearing from the March 2024 agenda to the April 2024 agenda, citing the need for sufficient preparation time and compliance with due process regulations by the applicants.
25. On March 21, 2024, Staff was contacted via email by members of the North Valley community and their neighborhood association, who requested a 90-day deferral. Additionally, concerns were raised regarding opposition members who attempted to comment during the discussion of the appeal at the March 21, 2024 hearing, despite the agenda item being closed for discussion, thus preventing any public comments.



26. Staff has received several emails in support and opposition at the time of this writing.

---

***FINDINGS: SITE PLAN FOR SUBDIVISION***

27. As noted in the Request on Page 8, the 2012 MDP initially contained a Site Plan for Subdivision, which received approval from the EPC. The Site Plan for Subdivision requires separate approval within the MDP framework, and both the MDP and the Site Plan for Subdivision are interdependent for their respective approvals.

Given that the MDP must encompass all components essential to a site plan for subdivision, encompassing design criteria for structures, landscaping, lighting, and signage, the procedure for this update will involve amending the Site Plan for Subdivision. The update includes all the textual revisions, impacting solely two sections for the MDP: Section 4, which deals with the Site Plan for Subdivision, and Section 6, which focuses on Design Performance Standards.

In addition to the revised textual content, the update incorporates site plan for subdivision sheets that show the location of existing and proposed developments within Balloon Fiesta Park. The updated sheets include a Site Plan Illustrative, a Site Plan for Subdivision Amendment, a Landscape Master Plan Major Amendment, and a Fencing Plan.

The updates include:

- a. Modifying the Site Plan for Subdivision to include the Outdoor Multi-Use Stadium in the area where a 5-6 multi-story parking structure was initially permitted under the approved MDP.
- b. Modifying the light standards as outlined in Section 6: Design Performance Standards.
- c. Replacing the Northeast Outdoor Recreation Area with surface parking.
- d. Introducing an additional adjacent tract for Balloon Fiesta Park's parking needs, facilitating the creation of 750 more parking spaces and expanding the park's total acreage from 358 acres to 367.5 acres.

***RECOMMENDATION – PR-2023-009363, SI-2023-01635, Major Amendment to the Balloon Fiesta Park Master Development Plan (MDP)/Site Plan for Subdivision***

***APPROVAL with conditions of Project # 2023-009363, SI-2023-01635, a Major Amendment request for an approximately 7-acre portion of a 367.5 acre site legally described as all or a portion of Tracts A-1 through G-1, Plat of Tracts A-1 through H-1, I-1-A & I-2-A, Tract I-A-A, Plat of Tracts A-1 through H-1, I-1A & I-2-A, and a fraction of Lot 2, located in NE ¼ NE ¼ Sec 11, T11N, R3E, a/k/a Tracts F & G, Heirs of Filiberto Gurule Tract, between Paseo del Norte NE and Roy Avenue NE, Zoned NR-PO-A, based on the preceding Findings and subject to the following Conditions of Approval.***

***CONDITIONS OF APPROVAL – PR-2023-009363, SI-2023-01635***

1. Upon approval by the EPC, the applicant shall coordinate with the Staff Planner to ensure that all conditions have been met within 6 months of the appeal period expiration date.

2. The applicant shall provide an updated Master Plan document to reflect this 2023 Major Amendment request and all previous administrative amendments to be posted on the City website within 6 months of the appeal period expiration date.

---

***FINDINGS – SI-2023-01638, Site Plan-EPC, March 21, 2024***

1. The request is a Site Plan – EPC Major Amendment for an approximately 7-acre portion of a 367.5 acre site legally described as all or a portion of Tracts A-1 through G-1, Plat of Tracts A-1 through H-1, I-1-A & I-2-A, Tract I-A-A, Plat of Tracts A-1 through H-1, I-1A & I-2-A, and a fraction of Lot 2, located in NE ¼ NE ¼ Sec 11, T11N, R3E, a/k/a Tracts F & G, Heirs of Filiberto Gurule Tract, between Paseo del Norte NE and Roy Avenue NE (the “subject site”).
2. The subject site is zoned NR-PO-A (Non-Residential Park and Open Space, city owned or managed Park Zone District), a zoning designation received upon adoption of the IDO. The subject site was formerly zoned SU-2 for Balloon Park Museum & Related Uses.
3. The EPC is hearing the request because, as per the Integrated Development Ordinance (IDO), a Site Plan – EPC because Site Plan approval is required on the 7-acre portion of BFP located north of the balloon launch field.
4. The request was heard and approved during the November 16, 2023 EPC hearing. Aggrieved parties appealed the decision citing improper mailed notice, errors in the decision-making process, and insufficient consideration of neighborhood concerns.
5. On February 16, 2024, the Land Use Hearing Officer (LUHO) remanded the case back to the EPC for a new hearing due to improper notification. The remand instructions state: The remand must be de novo, reheard anew.

“Notice shall be fully accomplished as required under the IDO: in areas in which the edge of that 100-foot buffer falls within any public right-of-way, adjacent properties will be included in the notice”.

The new hearing must also satisfy State ex. Rel. Battershell v. City of Albuquerque, 1989-NMCA-045, including the provision which allows for the opportunity for testimony and cross-examination.

6. The City’s Parks and Recreation Department holds the responsibility of overseeing the development as well as the management and operations at Balloon Fiesta Park, as defined by the Master Development Plan (MDP). The MDP, originally approved by City Council in 1998, serves as the primary governing document for Balloon Fiesta Park.
7. The applicant wishes amend the Balloon Fiesta MDP: to 1) eliminate the language that currently prohibits the use of an Outdoor Multi-Use Stadium; 2) Modifying the MDP and the associated Site Plan for Subdivision to include the Outdoor Multi-Use Stadium in the area where a 5-6 multi-story parking structure was initially permitted under the approved MDP; 3) Modifying the light standards as outlined in Section 6: Design Performance Standards to allow for stadium lighting; 4) Replacing the Northeast Outdoor recreation Area with surface parking; 5) introducing an additional adjacent tract for Balloon Fiesta’s parking needs, facilitating the creation of 750 more parking spaces and expanding the park’s total acreage from 358 acres to 367.5 acres
8. The subject site is located in an Area of Consistency and is in the North I-25 Community Planning Area (CPA). Alameda Boulevard is a designated Commuter Corridor as designated in the

Comprehensive Plan. The Little League section of BFP and the parking area at the Old Balloon Launch Field are within the boundaries of the Alameda Boulevard Design Overlay. Character Zones 1, 2, and 3 are under Bernalillo County's jurisdiction, while the majority of Character Zone 4 is situated within the City of Albuquerque.

9. The Albuquerque/Bernalillo County Comprehensive Plan, the Balloon Fiesta Park Master Development Plan, and the Integrated Development Ordinance (IDO) are incorporated herein by reference and made part of the record for all purposes.
10. The request is consistent with the following Comprehensive Plan Goal and Policies regarding Character from Chapter 4: Community Identity.

A. Goal 4.1 Character: Enhance, protect, and preserve distinct communities

The subject site is located in an Area of Consistency, and the proposed request is consistent with the goal of enhancing, protecting, and preserving the distinct character of the community. This consistency is achieved by establishing the Multi-Use Stadium within the existing Balloon Fiesta Park, in line with the objectives outlined in the Master Development Plan. Balloon Fiesta Park is a vital part of the North I-25 community, and the introduction of a new stadium, along with associated infrastructure improvements, aims to enhance, protect, and preserve this distinct community by offering an additional use/amenity that caters to the preferences of both local and statewide residents.

B. Policy 4.1.1 Distinct Communities: Encourage quality development that is consistent with the distinct character of communities.

The request would facilitate quality development that is consistent with the distinct character of the community because the proposed site plan is required to follow MDP design standards. The stadium's design, as depicted in the Site Plan, exemplifies high-quality development that matches the unique character of the North I-25 community. The layout adheres to the Balloon Fiesta Park Master Development Plan initially created in 1998 and updated in 2012. The amendments to the MDP will outline the desired development quality for this regional park facility that hosts the state's signature event while providing a range of indoor and outdoor recreational and cultural activities for residents, statewide residents, and visitors.

C. Policy 4.1.2 Identity and Design: Protect the identity and cohesiveness of neighborhoods by ensuring the appropriate scale and location of development, mix of uses, and character of building design.

The request would generally protect the identity and cohesiveness of neighborhoods nearby by ensuring the appropriate scale and location of development, mix of uses, and character of building design within the existing Balloon Fiesta Park. The scale and intensity of use shown on the Site Plan, Landscape Plan, and building elevations have been designed to reflect and improve existing site conditions while implementing the vision of the MDP. The stadium's height is less than the maximum height of 26 feet above the east property line/escarpment allowed by the MDP, which will further protect the identity and cohesiveness of nearby neighborhoods. While the Balloon Museum reaches a height of 75 feet, the proposed

stadium, like the Golf Training Center and Sid Cutter Pilot's Pavilion, was designed to harmonize with the area's character.

- D. Policy 4.1.3 Placemaking: Protect and enhance special places in the built environment that contribute to distinct identity and sense of place.

The request is consistent with this policy because Balloon Fiesta Park's unique status within the built environment contributes to the distinct identity and sense of place in the North I-25 area. The proposed amendments will allow for the development of the stadium, that has been designed to preserve the natural and man-made features of the park while enhancing the east escarpment and the northern side of Gondola Gulch. The area will further be protected and enhanced because the stadium's development will help address concerns related to the Nazareth Landfill by implementing measures to mitigate landfill gasses in coordination with Environmental Health.

11. The request is consistent with the following Comprehensive Plan Goals and Policies regarding land use and Areas of Consistency from Chapter 5: Land Use.

- A. Goal 5.2 Complete Communities: Foster communities where residents can live, work, earn, shop, and play together. r and needs.

The request is consistent with this Goal because the Site Plan and Major Amendment are designed to foster a community where residents can live, work, learn, shop, and socialize together. The introduction of the stadium to Balloon Fiesta Park will amplify opportunities for social engagement and leisure, all while generating new employment possibilities for residents. The stadium's construction and ongoing functions will provide job openings for community members, encompassing roles for construction workers, stadium personnel, and event-related services such as hospitality and concessions.

- B. Policy 5.2.1 – Land Uses: Create healthy, sustainable, and distinct communities with a mix of uses that are conveniently accessible from surrounding neighborhoods.

The request would contribute to a healthy, sustainable, and distinct community in the North I-25 CPA and its' neighborhoods because the Site Plan and Major Amendment would allow for additional use at BFP, making it easily accessible to nearby neighborhoods. The park is well connected to the City's trail network including the North Diversion Channel. In addition, the subject site is accessible to pedestrians, bicyclists, and transit users nearby via internal trails, sidewalks and a bike route along Alameda Boulevard.

- C. Policy 5.6.3 – Areas of Consistency: Protect and enhance the character of existing single-family neighborhoods, areas outside of Centers and Corridors, parks, and Major Public Open Space.

The request would generally enhance the existing park and protect the character of neighborhoods located in an Area of Consistency by thoughtfully siting the stadium within the park and avoiding the placement of incompatible uses.

12. The request is consistent with the following Comprehensive Plan Goal and Policies regarding Development Quality and Context from Chapter 7: Urban Design.

- A. Goal 7.3 – Sense of Place: Reinforce sense of place through context-sensitive design of development and streetscapes.

The proposed Site Plan, Landscape Plan, and building elevations, as outlined by the Site Plan – EPC, are guided by the MDP and are consistent with this Goal. The placement of the stadium has been carefully considered and is designed to seamlessly integrate within the escarpment while remaining below the high-voltage power lines. The MDP recognizes the advantages and challenges posed by the escarpment at Balloon Fiesta Park, including erosion issues affecting the park’s functionality. Balloon Fiesta Park is an integral part of the North I-25 community, and the introduction of the new stadium, along with associated infrastructure improvements, is focused on the development and streetscape design that harmonizes with the local context.

- B. Policy 7.3.5 – Development Quality: Encourage innovative and high-quality design in all development.

The Site Plan, building elevations, and stadium placement are consistent with this policy because the design is innovative and has high-quality features consistent with the proposed major amendment of the MDP. The stadium’s location has been carefully chosen and is nestled within the escarpment and positioned beneath the high-voltage lines, effectively incorporating the escarpment as a prominent architectural element. The design includes sloped walkways, grassy berm seating, and picnic areas.

- C. Goal 7.5 – Context Sensitive Site Design: Design sites, buildings, and landscape elements to respond to the high desert environment.

The building and landscape plans are consistent with this policy because they are specifically tailored to address the challenges of the high desert climate by incorporating shade features, canopies, and shade trees.

- D. Policy 7.5.1 – Landscape Design: Encourage landscape treatments that are consistent with the high desert climate to enhance our sense of place.

The Landscape Plan, a fundamental element of the Site Plan-EPC and in compliance with the MDP’s recommendations, is consistent with this policy because the designed landscape and plant selection are specifically tailored to thrive in Albuquerque’s high desert climate. The plant palette consists of trees, shrubs, groundcovers, and ornamental plants suited for this environment, contributing to the distinctive ambiance of Balloon Fiesta Park.

13. The request is consistent with the following Comprehensive Plan Goal and Policies regarding Facilities, Access & Universal Design from Chapter 10: Parks & Open Space.

- A. Policy 10.1 – Facilities & Access: Provide parks, Open Space, and recreation facilities that meet the needs of all residents and use natural resources responsibly.

The Site Plan and Major Amendment to the MDP are consistent with this Goal because they facilitate the development of a new section within Balloon Fiesta Park to cater to the needs of all residents while responsibly utilizing natural resources. The stadium and its associated improvements are designed for use by people of all ages and occupy an underutilized portion

of the Park initially designated for a multi-story parking structure. The Major Amendment will allow for an increase in parking capacity compared to the original MDP as land was acquired to the north for parking purposes, with the Site Plan showcasing a more efficient parking layout in this area.

- B. Policy 10.1.2 – Universal Design: Plan, design, program and maintain parks, Open Space, and recreation facilities for use by people of all age groups and physical abilities.

The Site Plan and Major Amendment to the MDP are consistent with this policy because the stadium and its surrounding improvements have been designed to accommodate to residents of all ages and physical abilities. The Site Plan also features improvements to the Gondola Gulch and the slope, improving accessibility for both pedestrians and vehicles within the Park. The project includes permanent restrooms that comply with the Americans with Disabilities Act (ADA) standards, ensuring accessibility for all visitors. Furthermore, the parking area to the north has been thoughtfully designed to include ADA, electric vehicle (EV), and motorcycle parking spaces, thereby increasing access and usability for people of all ages and physical abilities.

- C. Goal 10.2 – Parks: Provide opportunities for outdoor education, recreation, and cultural activities that meet community needs, enhance quality of life, and promote community involvement for all residents.

The request is consistent with this goal because the Site Plan and MDP Amendment will facilitate the expansion of outdoor activities at Balloon Fiesta Park. While the Stadium's primary purpose will be to host the New Mexico United soccer games (anticipated 17 annual home games), it is also designed to accommodate a diverse array of activities, including music events, food festivals, and cultural gatherings, all promoting community involvement. The Stadium's design is adaptable and will cater to various functions at Balloon Fiesta Park.

- D. Policy 10.2.1 – Park Types: Plan and implement a system of parks to meet a range of needs at different scales, including small neighborhood parks, community parks, active parks, regional parks, and linear parks.

The request is consistent with this policy because it will allow the City to improve its park system by adding more recreational amenities at Balloon Fiesta Park. The MDP Amendment will increase the park's size from 358 to 367.5 acres, solidifying its role as a primary regional park facility. The building and site will incorporate ADA design standards to serve the needs of persons of various ages and physical abilities.

- E. Goal 10.4 – Coordination: Coordinate across disciplines, jurisdictions, and geographies to leverage limited resources, maximize efficiencies, and best serve the public's need for parks and recreation facilities.

The Site Plan and Major Amendment to the MDP are consistent with this Goal because they will efficiently utilize constrained resources to bolster the continued growth of Balloon Fiesta Park and meet the community's need for parks and recreational amenities. A state-funded capital outlay of \$13.5 million has been allocated to address much-needed improvements in infrastructure, encompassing electrical, water, sewer, and telecommunications systems and networks within Balloon Fiesta Park. Additionally, private investments are designated for the construction of the Stadium.

- F. Policy 10.4.3 – Co-located Facilities: Maximize opportunities for multi-functional, co-located, and joint use of compatible parks, Open Space, trails, and recreation facilities to best leverage public investment.

State funds have been allocated for capital outlay that will extend and improve the infrastructure at Balloon Fiesta Park to attract significant private investments to support the construction of the Stadium. The request is consistent with this policy because the Site Plan will maximize the opportunities for a multi-functional park that enhances both passive/active recreation and community events.

14. The request is consistent with the following Comprehensive Plan Goal and Policy from Chapter 12: Infrastructure, Community Facilities & Services

- A. Goal 12.2 – Community Facilities: Provide communities facilities that have convenient access and a wide range of programs for residents from all cultural, age, geographical, and educational groups to enhance quality of life and promote community involvement.

The Site Plan and Major Amendment to the MDP are consistent with this goal because Balloon Fiesta Park benefits from accessible entry via I-25 through Balloon Fiesta Parkway. The proposed stadium, if the Major Amendment to the MDP is approved, will expand the existing array of programs and amenities, catering to a diverse audience of local and statewide residents, encompassing individuals of all ages, cultures, and educational backgrounds.

- B. Policy 12.2.3 – New Facilities: Site new facilities in areas with excellent access to provide services to underserved and developing areas.

The request is consistent with this policy because introducing a new facility at Balloon Fiesta Park, will leverage its excellent accessibility via Interstate 25 and Balloon Fiesta Parkway. Balloon Fiesta Park is designed to cater to a substantial number of visitors, and its location offers access to an area that is comparatively underutilized and underserved.

15. The request meets the Site Plan-EPC Review & Decision Criteria in IDO Section 14-16-6-6(J)(3) as follows:

- A. 14-16-6-6(J)(3)(a) As demonstrated by the policy analysis, the request is consistent with applicable Comprehensive Goals and Policies.
- B. 14-16-6-6(J)(3)(b) Before the adoption of the IDO, the subject site was zoned SU-2 for Balloon Park Museum & Related Uses. The subject site was never zoned NR-SU or PD. The existing zoning is under the jurisdiction of the established Master Development Plan (MDP), which details the regulations and protocols for proposed development. The MDP encompasses the guidelines for the review and approval process by the EPC, specifically for structures exceeding 10,000 square feet.

The existing language within the MDP explicitly prohibits the establishment of an Outdoor Sports Stadium at Balloon Fiesta Park. The Applicants are seeking a modification to the MDP permit development of an Outdoor Multi-Use Stadium. If the revised master plan is approved, all its terms and conditions will be adhered to.



- C. 14-16-6-6(J)(3)(c) The subject site must comply with all applicable provisions of the IDO, the DPM, and other adopted City regulations, including the Balloon Fiesta Park Master Plan.
  - D. 14-16-6-6(J)(3)(d) The City's existing infrastructure and public improvements have adequate capacity to support the Stadium project, with the exception of the electrical, water, and sewer systems. A state-funded capital outlay of \$13.5 million has been allocated to address much-needed improvements in infrastructure, encompassing electrical, water, sewer, and telecommunications systems and networks within Balloon Fiesta Park
  - E. 14-16-6-6(J)(3)(e) The future, proposed development would be required to comply with the decisions made by the EPC. The EPC's conditions of approval would improve compliance with the IDO, which contains regulations to mitigate site plan impacts to surrounding areas.
  - F. 14-16-6-6(J)(3)(f) The subject property is within the Balloon Fiesta Park Master Development Plan and the Site Plan meets relevant standards in the Balloon Fiesta Park Master Development plan and applicable standards in the NR-PO-A zone.
  - G. 14-16-6-6(J)(3)(g) A portion of the subject site falls within the Railroad and Spur Area, the proposed Stadium is not within 1,320 feet of a Residential zone district or a lot containing a residential use in any Mixed-Use zone District. In addition, the Stadium is not within 660 feet of another use as described in Subsection 5-2(E)(1)(c).
16. Following the LUHO hearing, agents representing the applicants sent notifications to all property owners residing within the 100-foot buffer zone, utilizing both property owner addresses and, if different, the site address. Notifications were distributed to properties situated along the east side of Edith Boulevard that fell outside the buffer, property owner addresses identified by the appellants as necessitating notification but located outside the buffer, and other neighboring property addresses.
- On March 1<sup>st</sup>, the City Parks and Recreation Department carried out a canvassing operation, delivering notification letters to all property sites within the buffer along the east side of Edith Boulevard. Consensus Planning provided confirmation to the Planning Department on March 4<sup>th</sup>, attesting to the completion of all requisite notification.
- Furthermore, Consensus Planning forwarded notification via email regarding the remanded March 21, 2024 EPC hearing. A facilitated meeting was held on March 4, 2024 with the participation of the two City-recognized neighborhood associations (Wildflower and District 4), as well as the Alameda North Valley, North Edith Corridor, and Maria Diers Neighborhood Associations.
17. A facilitated meeting was held on September 9, 2023 with the affected Neighborhood Associations. The community raised various issues, including heightened traffic, noise and lighting, funding concerns, and reservations about the pre-application meeting notification. These concerns and questions were duly acknowledged and addressed. Although a number of speakers, expressed their enthusiasm for the stadium, there were no explicit opposing comments.
18. On October 22, 2023, a meeting took place with three Project Team members in attendance, namely Matt Proctor from the Improve Group, and Ron Patel and David Wiese-Carl from NM United. This meeting was organized by residents of the North Alameda neighborhood and included representatives from the Wildflower neighborhood and other nearby areas. Approximately 30 people attended the meeting.

19. On November 2, 2023, an additional meeting was held with the Wildflower Neighborhood Association to discuss the proposed major amendment to the proposed multi-use stadium. During the meeting, members of the project team presented information related to the proposed developments including how the stadium's design has considered mitigating noise and light issues and information was shared about noise, sound, and traffic studies. The meeting included a question-and-answer period where attendees had the opportunity to ask questions and seek clarification on the presented information.

Overall, the meeting served as a platform for the Wildflower Neighborhood Association to engage with the Project Team, understand the proposed development, and express their concerns and inquiries regarding the Balloon Fiesta Park Master Development Plan Amendment and multi-use stadium plans.

20. Additional meetings following the submission of the application took place on multiple occasions during the planning process, involving the Alameda North Valley NA, Wildflower NA, Maria Diers NA, and the North Edith Corridor Association. On November 13, 2023 a meeting was held with industry representatives to provide them an opportunity to discuss the proposed project.
21. On March 4, 2024 a second facilitated meeting was held regarding the application for the proposed multi-use outdoor stadium that requires changes in the language of the BFP Master Development Plan/Site Plan for Subdivision/Site Plan-EPC. Attendees included many residents of nearby neighborhoods who are overwhelmingly in opposition to the proposed stadium. They have cited issues regarding noise, lighting, traffic, community disruption, impact on the area's rural character, decreased property values, as well as the intensity of the proposed uses at the stadium.

Other issues were discussed including the lease agreement concerns and inquiries regarding the business plan which are not the purview of the Environmental Planning Commission. In addition, an email was received from a member of the community containing questions meant to be addressed during the facilitated meeting, yet those questions were not discussed.

22. An email was received from a member of the community containing questions meant to be addressed during the facilitated meeting, yet those questions were not discussed.
23. On March 8, 2024, staff received an email from neighboring residents expressing their opposition to the stadium. They formally asked for the rescheduling of the EPC hearing from the March 2024 agenda to the April 2024 agenda, citing the need for sufficient preparation time and compliance with due process regulations by the applicants.
24. On March 21, 2024, Staff was contacted via email by members of the North Valley community and their neighborhood association, who requested a 90-day deferral. Additionally, concerns were raised regarding opposition members who attempted to comment during the discussion of the appeal at the March 21, 2024 hearing, despite the agenda item being closed for discussion, thus preventing any public comments.
25. Staff has received several emails in support and opposition at the time of this writing.

**RECOMMENDATION – PR-2023-009363, SI-2023-01638**

***APPROVAL with conditions of Project # 2023-009363, SI-2023-01638, a Site Plan-EPC request for an approximately 7-acre portion of a 367.5 acre site legally described as all or a portion of Tracts A-1 through G-1, Plat of Tracts A-1 through H-1, I-1-A & I-2-A, Tract I-A-A, Plat of Tracts A-1 through H-1, I-1A & I-2-A, and a fraction of Lot 2, located in NE ¼ NE ¼ Sec 11, T11N, R3E, a/k/a Tracts F & G, Heirs of Filiberto Gurule Tract, between Paseo del Norte NE and Roy Avenue NE, Zoned NR-PO-A, based on the preceding Findings and subject to the following Conditions of Approval.***

**CONDITIONS OF APPROVAL – PR-2023-009363, SI-2023-01638**

1. Upon approval by the EPC, the proposed site plan shall go to the Development Facilitation Team (DFAT) for final sign-off. The reviewer is responsible for ensuring that the EPC Conditions have been satisfied and that other applicable City requirements are met.
2. Based on the site plan revision, the applicant will be required to revise and provide finalized versions of the following documents to accommodate the new building footprint and extra row of parking:
  - A. Overall Landscape Plan
  - B. Landscape Plan – North & South
  - C. Overall Conceptual Utility Plan
  - D. Overall Grading & Drainage Plan
  - E. Grading & Drainage – North & South
3. The applicant shall coordinate with the Staff Planner prior to submitting to the DFT to ensure that EPC conditions have been met.
4. Site Lighting:
  - A. Parking area light pole maximum height shall not exceed 20’ as per the MDP.
  - B. Light fixtures shall be shielded using full cutoff light fixtures.
5. Vehicular Access, Circulation & Parking
  - A. Parking calculations shall be revised (Sheet 1)
  - B. Project date sheet for all parking shall be revised (Sheet 1).
6. Landscaping, Buffering & Screening
  - A. The Overall Landscape Plan shall be revised to correspond with the Site Plan parking calculations (Sheet 2).
7. Grading & Drainage Plan

- A. Pursuant to IDO Section 14-16-5-4(J)(4), grading in a Special Flood Hazard Area without an approved drainage report and financial guarantees for the permanent improvement is prohibited. The applicant shall supply an approved drainage report/financial guarantee.
8. Conditions from Crime Prevention Through Environmental Design.
  - A. Applicant shall coordinate with the Albuquerque Police Department regrading comments provided for Crime Prevention Through Environmental Design.
9. Condition from AMAFCA:
  - A. A Letter of Map Revision (LOMR) shall be prepared and accepted by FEMA to revise the limits of the floodplain for development to occur.
10. Condition from Environmental Services Division:
  - A. The final design and installation of landfill gas mitigations will be performed. Conditional EPC approval as related to landfill gas mitigation concerns appear to be a reasonable approach for development at this site.
11. Conditions from the Public Service Company of New Mexico (PNM) shall be addressed:
  - A. It is the applicant's obligation to determine if existing utility easements or rights-of-way are located on or adjacent to the property and to abide by any conditions or terms of those easements.
  - B. Any existing easements may have to be revised and/or new easements may need to be created for any electric facilities as determined by PNM. If existing electric lines or facilities need to be moved, then that is at the applicant's expense.
  - C. Any existing and/or new PNM easements and facilities need to be reflected on the Site Plan and any resulting Plat.
  - D. Typical electric utility easements widths vary depending on the type of facility. On-site transformers should have a five-foot clear area on the sides and rear and ten-foot front to allow for access and maintenance.
  - E. Structures, especially those made of metal like storage buildings, canopies, and stadiums should not be within or near PNM easements without close coordination with and agreement from PNM.
  - F. Perimeter and interior landscape design should abide by any easement restrictions and not impact PNM facilities. Please adhere to the landscape standards contained in IDO Section 14-16-5-6(C)(10) as applicable.

---

*Silvia Bolivar*

**Silvia Bolivar, PLA, ASLA  
Senior Planner**

CC:

City of Albuquerque/New Mexico United Soccer, [info@newmexicoutd.com](mailto:info@newmexicoutd.com)  
Consensus Planning, Jacqueline Fishman, Principal AICP, [fishman@consensusplanning.com](mailto:fishman@consensusplanning.com)  
Alameda North Valley Association Steve Wentworth [anvanews@aol.com](mailto:anvanews@aol.com)  
District 4 Coalition of Neighborhood Associations, Ellen Dueweke [edueweke@juno.com](mailto:edueweke@juno.com)  
District 4 Coalition of Neighborhood Associations, Mildred Griffiee [mgriffiee@noreste.org](mailto:mgriffiee@noreste.org)  
Wildflower Area NA Glenn Garcia [ggarcia103@comcast.net](mailto:ggarcia103@comcast.net)  
Wildflower Area NA Larry Caudill [ltcaudill@comcast.net](mailto:ltcaudill@comcast.net)  
Sandy Zuschlag, [szuschlag58@gmail.com](mailto:szuschlag58@gmail.com)  
Steve Wentworth, [swent999@aol.com](mailto:swent999@aol.com)  
Pat Houser, [hdhauser@comcast.net](mailto:hdhauser@comcast.net)  
Michael Haederle, [haederle@yahoo.com](mailto:haederle@yahoo.com)  
Kevin Murray, [claystorm@gmail.com](mailto:claystorm@gmail.com)  
Aaron Reeder, [aaron.reederiv@gmail.com](mailto:aaron.reederiv@gmail.com)  
Annette Pitera, [annette@ahcnm.org](mailto:annette@ahcnm.org)  
Joanie Griffin, [jgriffin@sunny505.com](mailto:jgriffin@sunny505.com)  
David Carl, [dave.carl923@gmail.com](mailto:dave.carl923@gmail.com)  
Randi Guthrie, [homesbyrandi@gmail.com](mailto:homesbyrandi@gmail.com)  
Ellen Jones, [ellenotr3@gmail.com](mailto:ellenotr3@gmail.com)  
Rachel Jones, [Rachel.johnson@navihealth.com](mailto:Rachel.johnson@navihealth.com)  
Joshua Martin, [joshisjosh83@gmail.com](mailto:joshisjosh83@gmail.com)  
Gloria Faber, [office@nmyma.net](mailto:office@nmyma.net)  
Rachel Babb – [rachel72babb@gmail.com](mailto:rachel72babb@gmail.com)  
William Babb, [wbabb@salud.unm.edu](mailto:wbabb@salud.unm.edu)  
Robert Romero, [rgoalierob@icloud.com](mailto:rgoalierob@icloud.com)  
Thomas Cooley, Ph.D., [thomas.cooley@comcast.net](mailto:thomas.cooley@comcast.net)  
Annette Santiago Kitts, [cbear5434@gmail.com](mailto:cbear5434@gmail.com)  
LuElena Gonzales, [luelenagonzales@hotmail.com](mailto:luelenagonzales@hotmail.com)  
Maggie Rose, [gyppy.rose46@gmail.com](mailto:gyppy.rose46@gmail.com)  
Brooke Jordy, [brookemjordy@gmail.com](mailto:brookemjordy@gmail.com)  
Tina Villegas, [t-marie-v@hotmail.com](mailto:t-marie-v@hotmail.com)  
Amy Rehfeld, [amyrehfeld@gmail.com](mailto:amyrehfeld@gmail.com)  
Andrew Hageman, [andyhageman@comcast.net](mailto:andyhageman@comcast.net)  
Danette Medina, [danettemedina@yahoo.com](mailto:danettemedina@yahoo.com)  
Debbie & Pat Bryan, [pdbryan57@gmail.com](mailto:pdbryan57@gmail.com)  
Glenn Felty, [glenn@sunstatesolar.net](mailto:glenn@sunstatesolar.net)  
D'Val Westphal, Greater Albuquerque Chamber of Commerce, [dwestphal@greaterabq.com](mailto:dwestphal@greaterabq.com)  
Annette Pitera, Hispano Chamber of Commerce, [Annette@ahcnm.org](mailto:Annette@ahcnm.org)  
United Way of North Central New Mexico, [Tracy.Brooks@uwncnm.org](mailto:Tracy.Brooks@uwncnm.org)  
Jake Gutierrez, [kickingtv@gmail.com](mailto:kickingtv@gmail.com)  
Karl Wiese, [wiesepi@gmail.com](mailto:wiesepi@gmail.com)  
Michael Lewis, [michael@michaelslewis.com](mailto:michael@michaelslewis.com)  
Randi Guthrie, [homesbyrandi@gmail.com](mailto:homesbyrandi@gmail.com)  
Robert Dunham, [durhamabq@comcast.net](mailto:durhamabq@comcast.net)  
Robert Romero, [rgoalierob@icloud.com](mailto:rgoalierob@icloud.com)  
Rodney Prunty\_United Way of Central NM  
Terrye Mola, [terryemola@gmail.com](mailto:terryemola@gmail.com)  
Thomas Colley, [Thomas.cooley@comcast.net](mailto:Thomas.cooley@comcast.net)

Tim Spears, [tspears@ultramain.com](mailto:tspears@ultramain.com)  
Tom Kennedy, [tk37ford@gmail.com](mailto:tk37ford@gmail.com)  
Peggy Norton, [peggynorton@yahoo.com](mailto:peggynorton@yahoo.com)  
Angela Stell, [angela@nmdog.org](mailto:angela@nmdog.org)  
Anthony Lovato, [antonylovato@comcast.net](mailto:antonylovato@comcast.net)  
Rosalie Johnson, [rosiegi44@yahoo.com](mailto:rosiegi44@yahoo.com)  
Edie Myers, [emyers\\_11@yahoo.com](mailto:emyers_11@yahoo.com)  
James Welty, [jawelty@comcast.net](mailto:jawelty@comcast.net)  
Sarah Shortle, [sarahshortle@comcast.net](mailto:sarahshortle@comcast.net)  
Leslie Linthicum, [leslielinthicum@gmail.com](mailto:leslielinthicum@gmail.com)  
Regina Jolley, [gjolley007@gmail.com](mailto:gjolley007@gmail.com)  
Tania Gonzalez, [tserafin30@gmail.com](mailto:tserafin30@gmail.com)  
Bari Harvey, [boyznbari@msn.com](mailto:boyznbari@msn.com)  
Becca Hall, [kbbh@hotmail.com](mailto:kbbh@hotmail.com)  
Sacheen Harris, [sacheen.harris@icloud.com](mailto:sacheen.harris@icloud.com)  
Lauren Ferguson, [Ferguson.lauren.e@gmail.com](mailto:Ferguson.lauren.e@gmail.com)  
Jo Ann Wildenstein, [jawildenstein@gmail.com](mailto:jawildenstein@gmail.com)  
Mary Cooley, [mary.cooley@comcast.net](mailto:mary.cooley@comcast.net)  
Jeff Janas, Greater Albuquerque Chamber of Commerce, [jjanas@greaterabq.com](mailto:jjanas@greaterabq.com)  
Aaron Reeder, [aaron.reederiv@gmail.com](mailto:aaron.reederiv@gmail.com)  
Annette Pitera, [Annette@ahcnm.org](mailto:Annette@ahcnm.org)  
David Carl, [dave.carl923@gmail.com](mailto:dave.carl923@gmail.com)  
Ellen Jones, [ellenotr3@gmail.com](mailto:ellenotr3@gmail.com)  
Rachel James, [Rachel.johnson@navihealth.com](mailto:Rachel.johnson@navihealth.com)  
Joshua Martin, [joshisjosh83@gmail.com](mailto:joshisjosh83@gmail.com)  
Legal, [Dking@cabq.gov](mailto:Dking@cabq.gov)  
EPC file

LAND USE HEARING OFFICER (LUHO)

REMAND INSTRUCTIONS

AC-23-22

1  
2  
3  
4  
5  
**CITY OF ALBUQUERQUE**  
**LAND USE APPEAL UNDER THE IDO**  
**BEFORE AN INDEPENDENT**  
**LAND USE HEARING OFFICER**

6 **APPEAL NO. AC-23-22**

7 PR-2023-0093363; SI-2023-01635; SI-2023-01638; VA-2023-00356

8  
9 Patrick Hauser, *et al.*,

10  
11 Appellants.

12  
13 Consensus Planning, agents for  
14 City of Albuquerque/ New Mexico United,

15  
16 Appellees/ Party Opponents.

17  
18 **REMAND**

19  
20 Patrick Hauser and 66 other Appellants appealed a decision made by the Environmental  
21 Planning Commission (EPC) at a public hearing held on November 16, 2023. At that hearing,  
22 the EPC approved an application for a Major Amendment to the Balloon Fiesta Park Master  
23 Development Plan. The EPC also approved an associated site plan to replace the existing site  
24 plan. The intent of the Master Plan Amendment and new site plan is to allow for a new outdoor  
25 multi-use stadium at the Balloon Fiesta Park.

26 The appeal was timely filed. Among the issues raised by Appellants in their appeal was  
27 that notice of the EPC hearing to at least nine property owners and potentially more, as required  
28 by § 6-4(K)(3) of the Integrated Development Ordinance (IDO), was not accomplished. It is  
29 not disputed that the manner of notice to interested property owners within 100-feet of the  
30 application site is encompassed in IDO, § 6-4(K)(3)(c).



31 At the appeal hearing held on February 16, 2024, the Appellee-Party Opponents  
32 through their able legal counsel stipulated that at least nine property owners who meet the  
33 proximity regulation encompassed in § 6-4(K)(3)(c) were not sent notice. In addition, the  
34 Appellee-Party Opponents agree that a remand is necessary.

35 There is no dispute that the EPC is a quasi-judicial body. And even though the technical  
36 rules of evidence and the Rules of Civil Procedure Courts follow do not apply in EPC hearings,  
37 there are various legal principles and rules which must be followed under New Mexico law.  
38 For example, as a quasi-judicial body, the provisions of constitutional due process as well as  
39 the fundamental rules of fairness must be adhered to. Notice of hearings, the right to be heard,  
40 and the right to cross examine witnesses are corner stones of due process. See generally *State*  
41 *ex rel. Battershell v. City of Albuquerque*, 1989-NMCA-045.

42 A remand would not only be expeditious to a final resolution of the appeal, but it is  
43 quintessential to remedying the notice deprivation. The remand must be *de novo*, reheard anew.  
44 Although Appellants wish to have the substantive merits of their appeal heard now, there is no  
45 benefit in examining the substantive merits of the appeal when a *de novo* remand hearing is  
46 necessary. Because this matter must be remanded, an examination of the merits of the appeal  
47 now could prejudice a party in the subsequent remanded hearing.

48 Accordingly, this matter is remanded to the EPC for a new hearing. Notice shall be  
49 fully accomplished as required under the IDO; in areas in which the edge of that 100-foot  
50 buffer falls within any public right-of-way, adjacent properties will be included in the notice.

51 The new hearing must also satisfy *State ex rel. Battershell v. City of Albuquerque*, 1989-  
52 NMCA-045, including the provision which allows for the opportunity for testimony and cross-  
53 examination.

54 Respectfully Submitted:

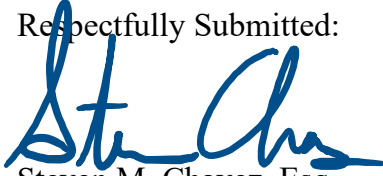
55 

56 Steven M. Chavez, Esq.  
57 Land Use Hearing Officer  
58 February 17, 2024

59 Copies to:

60 City Council  
61 Appellants  
62 Appellees/ Party Opponents  
63 Planning Staff

64  
65

## APPLICANT INFORMATION

UPDATE TO JUSTIFICATION LETTER

TRAFFIC IMPACT ANALYSIS

UPDATED LIGHTING ANALYSIS



# Memorandum

**To:** Silvia Bolivar  
**From:** Jacqueline Fishman, AICP, Principal  
**Date:** March 6, 2024  
**Re:** **Balloon Fiesta Park / United Soccer Stadium**

The purpose of this memo is to document the actions and revisions that have been made to our application for Major Amendment to the Balloon Fiesta Park Master Development Plan and the Site Plan-EPC for a Multi-purpose Stadium. This memo is accompanied by a revised set of building elevations and cross sections from the east edge of the residential development to the west of Balloon Fiesta Park to the location of the proposed stadium.

## 1) Notification

The LUHO remanded the request to the Environmental Planning Commission based on incomplete notification to seven property owners west of the Park. The Applicants requested the remand, acknowledging the mistake. On February 28<sup>th</sup> and 29<sup>th</sup>, Consensus Planning emailed notification of the remanded March 21<sup>st</sup> EPC hearing and a facilitated meeting on March 4<sup>th</sup> to the two City-recognized neighborhood associations (Wildflower and District 4), plus Alameda North Valley, North Edith Corridor, and Maria Diers neighborhood associations; and mailed notification to all property owners within the 100-foot buffer, both at the property owner address and the site address if it was different than the property owner address; all properties along the east side of Edith Boulevard that were outside the buffer; property owner addresses that the appellants thought were required to be notified but were outside the buffer; and other nearby property owner addresses. On March 1<sup>st</sup>, City Parks and Recreation also canvassed the area and placed notification letters at all property sites within the buffer and along the east side of Edith Boulevard. Consensus Planning provided verification to the Planning Department on March 4<sup>th</sup> that all said notification was completed.

## 2) Facilitated Meeting

Given the issues with notification, we decided that it would make sense to hold a facilitated meeting even though one was not required by the LUHO in remanding the case to EPC. The facilitated meeting was held on March 4<sup>th</sup> via Google Meet. The meeting date was agreed to by Brooke Jordy, who stated that she was asked by the primary appellant, Pat Hauser, to call me after I had left messages for Mr. Hauser regarding scheduling a facilitated meeting. Ms. Jordy also appeared before the LUHO and briefly spoke for the appellants. In our phone conversation, Ms. Jordy agreed to the facilitation meeting being held on March 4<sup>th</sup>. I have attached email communication regarding the facilitated meeting between myself and the neighborhood representatives. It appears that some of the neighborhood representatives were unhappy about the timing of the facilitated meeting; however, it also appeared most of them were in attendance. Given their concerns about the limited amount of time given to speakers at the EPC hearings, the facilitated meeting was primarily intended as a listening session to give participants an extended amount of time to voice their concerns and ask questions. Most of the speakers

expressed their opposition to the project. Please reference the facilitation report for detailed information.

### **3) Building Elevations**

In response to concerns expressed by some of the neighbors, the Applicant has made revisions to the building elevations, which are attached to this memo. Details regarding those changes include:

- The stadium has been reduced to a 3-4 story structure with a maximum building height of 65 feet above pitch level (which is relative to the 5058') contour). The lower profile further diminishes scale and allows the stadium to further blend in with the height of the surrounding escarpment. At the base of the elevation there will be more earthen berms incorporated, which will increase ability to buffer sound and create more landscape / passive park recreation opportunities.
- The west side roof overhang has been increased to cover the entire west side seating bowl in order to further improve sound control. The broader roof also improves the ability to install a distributed sound system.
- The stadium building footprint has been moved approximately 16 to 18 feet further to the east and 5 to 10 feet to the south in order to increase embedment into the escarpment.

### **4) Cross Sections**

The project architect has created a cross section showing a sight line from houses along Edith to the stadium area, which is attached to this memo. The cross section shows that the stadium cannot be seen from the houses. The second floor levels of some houses will see the stadium but views of the Sandias are not blocked.

### **5) Light Poles**

The height of the east light poles at the stadium have been reduced by 10 feet, from 100 feet down to a maximum of 90 feet above the field. This responds to concerns over lighting.

### **6) Sound Impact Analysis**

A memo to the original Sound Study has been provided further clarifying conformance with Noise Ordinances and outlining future steps to do on-site acoustical testing and validation of parameters.

Please do not hesitate to contact me with any questions you may have regarding the Site Plan or any other aspect of the project.

**From:** [Jackie Fishman](#)  
**To:** [Pat Hauser](#); [thummell@cabq.gov](mailto:thummell@cabq.gov); [phcrumpsf@gmail.com](mailto:phcrumpsf@gmail.com); [sabolivar@cabq.gov](mailto:sabolivar@cabq.gov)  
**Cc:** [Maggie Rose](#); [Michael Haederle](#); [Steve Wentworth](#); [Peggy Norton](#); [Evelyn Harris](#); [Brooke Jordy](#); [boyznbari@msn.com](mailto:boyznbari@msn.com); [Sandy Zuschlag](#); [Steve Taylor](#); ["Steve Horchheimer"](#); ["Edie Myers"](#); [t-marie-v@hotmail.com](mailto:t-marie-v@hotmail.com); [Christine Benavidez](#); ["Lorraine Montoya"](#)  
**Subject:** Re: Balloon Fiesta Park and NM United  
**Date:** Thursday, February 29, 2024 12:49:58 PM

---

For clarification, the remand is based on the seven property owner addresses that were inexplicably not included in the original notice of hearing last October. Hearing notification is required 15 days before the hearing- we have done this well in advance of the required timeframe.

This is what the LUHO's decision said:

“Notice shall be fully accomplished as required under the IDO; in areas in which the edge of that 100-foot buffer falls within any public right-of-way, adjacent properties will be included in the notice.”

We have notified the two City recognized associations, as well as Alameda North Valley, who apparently is no longer recognized, Maria Diers, and North Edith. We have also sent notice to the addresses in the buffer area and added other property owner addresses that were not required to be notified.

City Parks and NM United will be out canvassing the area on Saturday with copies if the notice.

To clarify regarding the meeting on Monday, this was not required by the remand, but we wanted to have a neutral facilitator conduct the meeting and prepare the report that goes to EPC. We can discuss whether further discussion is needed beyond the Monday meeting.

I've copied the two meeting facilitators, Phillip and Tyson, on this email as well as the case planner, Silvia. If you have further questions about the facilitated meeting, remand process, or the EPC hearing, please direct to them.

Jackie Fishman, AICP  
Principal

---

**From:** Jackie Fishman <[fishman@consensusplanning.com](mailto:fishman@consensusplanning.com)>  
**Sent:** Wednesday, February 28, 2024 2:04 PM  
**To:** Pat Hauser <[hdhauser@comcast.net](mailto:hdhauser@comcast.net)>; thummell@cabq.gov <[thummell@cabq.gov](mailto:thummell@cabq.gov)>; phcrumpsf@gmail.com <[phcrumpsf@gmail.com](mailto:phcrumpsf@gmail.com)>  
**Cc:** Maggie Rose <[gypsy.rose46@gmail.com](mailto:gypsy.rose46@gmail.com)>; Michael Haederle <[haederle@yahoo.com](mailto:haederle@yahoo.com)>; Steve Wentworth <[Anvanews@aol.com](mailto:Anvanews@aol.com)>; Peggy Norton <[peggynorton@yahoo.com](mailto:peggynorton@yahoo.com)>; Evelyn Harris <[grumpyeh46@comcast.net](mailto:grumpyeh46@comcast.net)>; Brooke Jordy <[brookemjordy@gmail.com](mailto:brookemjordy@gmail.com)>; boyznbari@msn.com <[boyznbari@msn.com](mailto:boyznbari@msn.com)>; Sandy Zuschlag <[szuschlag58@gmail.com](mailto:szuschlag58@gmail.com)>; Steve Taylor <[staylor@taylortowers.com](mailto:staylor@taylortowers.com)>; 'Steve Horchheimer' <[stemax1@aol.com](mailto:stemax1@aol.com)>; 'Edie

Myers' <emyers\_11@yahoo.com>; t-marie-v@hotmail.com <t-marie-v@hotmail.com>;  
Christine Benavidez <christinebnvdz@aol.com>; 'Lorraine Montoya'  
<alamedamontoya@gmail.com>

**Subject:** RE: Balloon Fiesta Park and NM United

Pat –

I agree that the meeting shouldn't be during the day as that would prevent working people from participating. The meeting would be via Zoom and in the evening.

I spoke with Brooke this morning and proposed this coming Monday evening for the facilitated meeting. She was agreeable to that date and so I have notified our team. I'm hoping that is agreeable to you as well.

Our intent is to be back in front of the EPC for the March 21<sup>st</sup> hearing. We are gearing up this afternoon to start sending out notifications today. The representatives from the City recognized associations, as well as representatives from the County neighborhood associations, will be receiving an official email notification today from my office. We are also sending out certified mail notices to all property owners within the 100-foot buffer; that list has been vetted and confirmed with the Planning Department's GIS Manager. We are also sending first class mail to the other property owners that were on your map, everyone who attended any of the seven meetings that provided a mailing address, and every address along the east side of Edith. Parks and Rec will be going door to door with copies of the notice as well. This means some people will likely get 2 or 3 notices in our effort.

I suspect the main agenda item is going to be sound. Let me know if there are specific other items that you would like our team to address.

Please feel free to give me a call to discuss.

Jacqueline Fishman, AICP  
Principal  
Consensus Planning, Inc.  
302 Eighth Street NW  
Albuquerque, NM 87102  
P: 505.764.9801

---

**From:** Pat Hauser <hdhauser@comcast.net>

**Sent:** Wednesday, February 28, 2024 11:50 AM

**To:** Jackie Fishman <fishman@consensusplanning.com>

**Cc:** Maggie Rose <gypsy.rose46@gmail.com>; Michael Haederle <haederle@yahoo.com>; Steve Wentworth <Anvanews@aol.com>; Peggy Norton <peggynorton@yahoo.com>; Evelyn Harris

<grumpyeh46@comcast.net>; Brooke Jordy <brookemjordy@gmail.com>; boyznbari@msn.com; Sandy Zuschlag <szuschlag58@gmail.com>; Steve Taylor <staylor@taylortowers.com>; 'Steve Horchheimer' <stemax1@aol.com>; 'Edie Myers' <emyers\_11@yahoo.com>; t-marie-v@hotmail.com; Christine Benavidez <christinebnvdz@aol.com>; 'Lorraine Montoya' <alamedamontoya@gmail.com>

**Subject:** RE: Balloon Fiesta Park and NM United

Good morning Ms. Fishman: Thanks for the message regarding the proposed meeting. Your telephone number was blocked on my cellphone as a potential Spam number. Not sure why maybe since you are not in my contact list.

Based on my limited knowledge regarding the meeting it would seem as if it is being planned as a Zoom or something of that nature.

My experience has been that if such a meeting is conducted during the day it seriously hampers many individuals from attending due to their business or work schedules.

I would like to contact several of the other Associations and get their input regarding a possible best time to proceed with such a meeting.

It would also be helpful to know the agenda items and what is planned for possible discussion items that will impact we the property owners.

I have taken the liberty to copy several individuals in on our communication regarding a proposed meeting.

Thanks in advance for working with us on this subject.

Regards: Pat Hauser

---

**From:** Jackie Fishman <[fishman@consensusplanning.com](mailto:fishman@consensusplanning.com)>

**Sent:** Wednesday, February 28, 2024 8:51 AM

**To:** [hdhauser@comcast.net](mailto:hdhauser@comcast.net)

**Cc:** [gypsy.rose46@gmail.com](mailto:gypsy.rose46@gmail.com); [phcrumpsf@gmail.com](mailto:phcrumpsf@gmail.com)

**Subject:** Balloon Fiesta Park and NM United

**Importance:** High

Hi Pat –

I left you a voicemail yesterday in regard to the EPC remand. We would like to schedule a meeting to discuss the project and I've copied the meeting facilitator. We are working on notification and have greatly expanded the list of who we will be sending notification to. Given the number of associations and individuals involved, I would like to work with you to pick a meeting date next week and then my office will add the date to the notification. Could you or



Maggie please either email me back or call me to discuss your availability next week?

Thanks, and hope to hear from you soon.

Jacqueline Fishman, AICP  
Principal  
Consensus Planning, Inc.  
302 Eighth Street NW  
Albuquerque, NM 87102  
P: 505.764.9801

**TO: IMPROVE GROUP**

NM UNITED STADIUM NOISE STUDY

March 6, 2024

In the ongoing efforts to further test, analyze and validate suitability of the design, which will reduce sound migration from the stadium to the greatest extent and within required ordinances, the following additional information and future work narrative is provided.

Scope of Work relative to a future site visit to further validate environmental conditions and acoustical modeling criteria:

1. Refer to the initial acoustical model for projected stadium sound system performance levels.
  - a. Building and orientation updates to the model will be provided as needed.
2. Measure current [ambient] SPL (sound pressure levels) at the specific neighborhood locations in question in order to establish control data for the testing process.
3. Provide a portable loudspeaker system to generate Pink Noise at sufficient SPL from a single point at or near the proposed stadium location.
4. Acquire SPL measurements at the noise generation point.
5. Acquire SPL measurements at specified neighborhood test locations, with the Pink Noise audio generated from the center of the proposed stadium location.
6. Timing and conditions of test will conform to the primary time of soccer games & events.
7. Log the measurements for inclusion in the site test report.
8. Create a narrative describing the test findings and associated descriptive recommendations.

Considerations and details relative to testing, recommendations, and design criteria. The City, County, and Park Noise Ordinance guidelines have been reviewed and are assumed applicable in the following:

1. The City's Noise Ordinance states that sound pressure levels shall not exceed 50 dBA at any noise sensitive property line between 10 p.m. and 7 a.m.
2. Where ambient local level exceeds 50 dBA, the criteria shall be ambient, plus 5 dBA.
3. Amplified sound is allowed between the hours of 7 a.m. and 10 p.m. only but shall not exceed the noise limits as stated above.
4. Where ambient local noise level exceeds 50 dBA, the sound level shall not exceed ambient plus 5 dBA.
5. No person at an event shall be exposed to amplified sound over 90 dBA at any time.
6. Exceptions for short-term special events and lessees may be allowed on a case-by-case basis under a temporary permit obtained through the Environmental Health Department.
  - a. If approved, this would allow limited, short duration, non-compliance with the Noise Ordinance standards. The event operator shall monitor noise to ensure it meets the standards of the City's Noise Ordinance and the special provisions of permits and leases.
  - b. The event operator shall monitor noise to ensure it meets the standards of the City's Noise Ordinance and the special provisions of permits and leases.
7. Soccer and other public events at the new stadium are planned to end prior to 10:00 PM MST.
8. Should a special event be considered that extends past this timeframe, the management of the venue will follow the City Noise Ordinance guidelines and apply for a temporary permit prior to scheduling said event.

9. Sound system technologies and design methods for the new stadium include containing as much of the amplified audio as possible within the stadium, in an effort to reduce SPL leakage into the surrounding neighborhoods.
  - a. This design has been successfully installed at Boston College's football stadium and is currently in the process of being installed at the Rose Bowl in Pasadena, CA and is proposed for the new White Soccer Stadium in Boston, MA.
  - b. Utilizing construction design methods in the stadium to block and reduce the intensity of SPL within the stadium is also planned.
  - c. Physical orientation of the stage location for special events will be addressed in the building design.
  - d. Technology will be integrated in the sound system to allow the facility management to monitor and immediately mute audio tie-lines from concert events should the system operator exceed the stated noise ordinance levels.



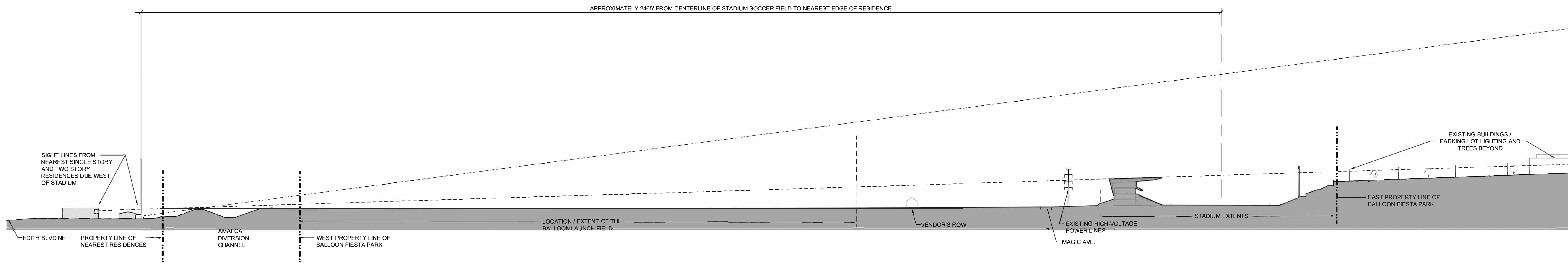

WEST - EAST CROSS SECTION VIEW OF OVER 1/2 MILE FROM EDITH BLVD. TO FAR EAST PARK LIMITS  
1" = 100'-0"



EXISTING SITE CONDITIONS GEOGRAPHIC PROFILE DIAGRAM  
NTS

BALLOON FIESTA PARK  
**MULTI-USE  
STADIUM**

CITY OF ALBUQUERQUE

**PROJECT TEAM**  
PLANNING/LANDSCAPE ARCHITECTURE  
CONSENSUS PLANNING  
ARCHITECTURE  
IMPROVE GROUP +  
ODELL A LABELLA COMPANY  
ENGINEERING  
BOHANNAN HUSTON

SITE DEVELOPMENT PLAN FOR BUILDING PERMIT  
Context Analysis Drawings



January 16, 2024

Olin Brown, PE  
Bohannon Huston  
7500 Jefferson St NE  
Albuquerque, NM 87109

**Re: *Proposed United Stadium and Balloon Fiesta Park Traffic Comparison***

## Introduction

This memo details the procedures and findings of an Initial Traffic Assessment performed by Lee Engineering for Bohannon Huston. The memo and analysis conducted herein were performed for the proposed United Soccer League (USL) stadium in Albuquerque, NM, within the Balloon Fiesta Park area. The stadium is expected to generate 3,167 passenger vehicle trips at maximum capacity and 1,900 passenger vehicle trips for regular season games with average attendance. The proposed stadium will provide approximately 2,850 parking spaces, with 1,090 optional parking spaces in the surrounding lots.

This assessment examines the impacts of the proposed development on surrounding traffic conditions and discusses the potential impacts of trips generated by the development on the study intersections. Regular season United games are scheduled to begin at 7 PM; this analysis concentrates on the hours between 4 PM and 10 PM. Potential impacts are examined using HCS traffic analysis software, and results are presented in comparison with previously collected Balloon Fiesta event and non-event data. Finally, a traffic control concept is established.

## Results Summary

The trip generation for an average attendance United game resulted in 1,900 ingress and egress trips, with 3,167 projected for a maximum capacity attendance event. These results are based on a vehicle occupancy rate of 3.6 persons per vehicle calculated from United's current attendance and parking data. The vehicle-per-hour processing capacity is roughly 2,000 vehicles based on the vehicle counts and video observations conducted by Lee Engineering during Balloon Fiesta ingress and egress.

The average attendance trips combined with the normal area traffic during the identified ingress and egress periods are comparable to weekday PM peak hour conditions and will require a similar level and intensity of traffic control as presently implemented for the United games held at the Isotopes Park. When combined with the normal background traffic, maximum attendance stadium event traffic results in traffic demand volumes surpassing the gateway intersection's capacity and requires a more significant traffic control footprint.

## Study Area and Site Routing

The proposed stadium location is adjacent to the Balloon Fiesta Park grounds. Figure 1 depicts the study vicinity along with the gateway and internal intersections. Figure 2 shows the stadium's location within the park, and the proposed access routing for stadium ingress and egress traffic is shown in Figure 3.

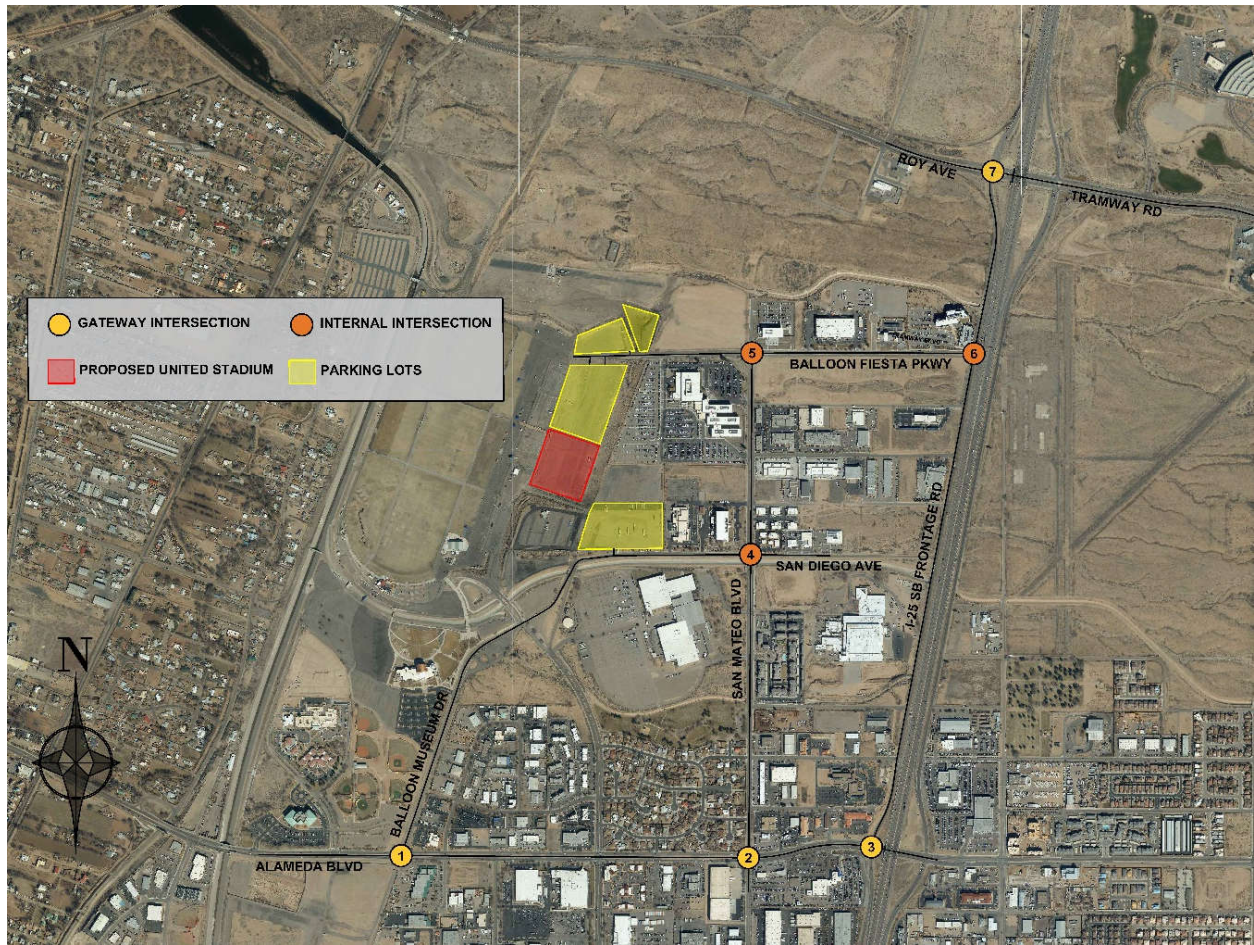

Figure 1: Vicinity Map



Figure 2: Proposed United Soccer League Stadium and Parking Site Plan



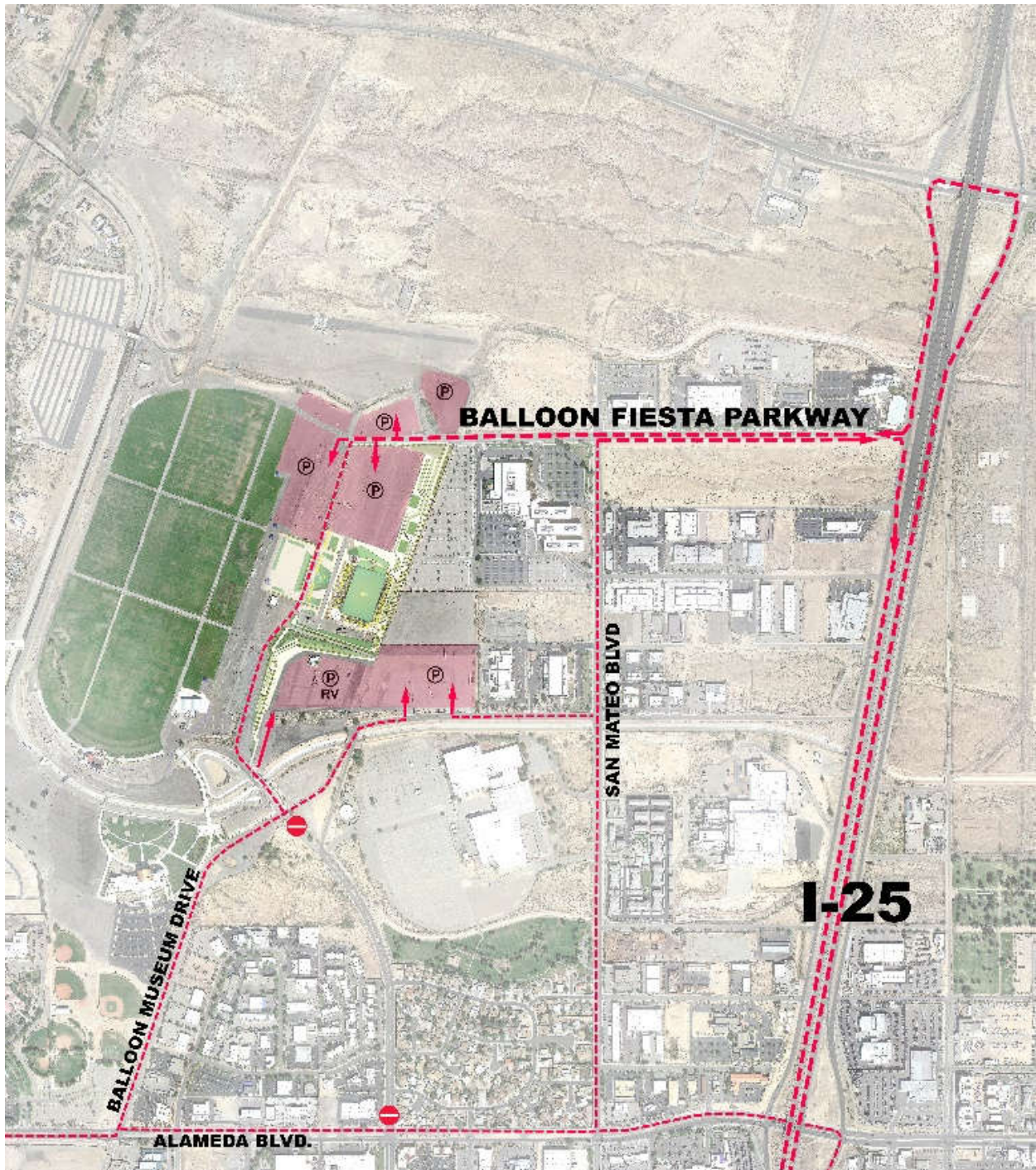

Figure 3: Proposed Vehicle Ingress and Egress Routing



The four signalized intersections bordering the Balloon Fiesta Park study area that carry ingress and egress traffic streams are as follows:

- Alameda Blvd and Balloon Museum Dr
- Alameda Blvd and San Mateo Blvd
- Alameda Blvd and Southbound Pan American Frontage Rd
- Roy Ave/Tramway Blvd and Southbound Pan American Frontage Rd

For simplicity, all of the four intersections above are hereafter referred to as gateway intersections. However, to be clear, only three of these signalized intersections listed above serve as gateways to the Balloon Fiesta Park. Per the proposed ingress and egress route, all stadium-bound traffic would pass through one of these: Alameda Blvd and Balloon Museum Dr, Alameda Blvd, and San Mateo Blvd, and Roy Ave and Pan American Frontage Rd.

In addition to the signalized intersections bordering the Balloon Fiesta Park area, there are three stop-controlled intersections within the study area pivotal to ingress and egress flow:

- San Mateo Blvd and San Diego Ave
- San Mateo Blvd and Balloon Fiesta Pkwy
- Southbound Pan American Frontage Rd and Balloon Fiesta Pkwy

These intersections were identified for study based on the proposed ingress and egress route to determine the potential effect of the stadium-generated traffic volumes on their operational performance. Additionally, the results of these determinations were used to identify the locations and scope of potential traffic control measures, such as active traffic management at intersections by police officers or special event signal timing plans. The following are descriptions of each of these intersections:

### **Intersection Descriptions**

**Alameda Blvd and Balloon Museum Dr** is a four-legged signalized intersection with available pedestrian facilities on all approaches. The northbound approach on Balloon Museum Dr includes two travel lanes from the South RV Lot Entrance, which remains closed until the Balloon Fiesta Event. The east and westbound approaches on Alameda Blvd have two travel lanes and a left turn lane separated by a chevron-striped buffer. The eastbound approach also includes a channelized right turn lane with a marked crosswalk. The southbound approach on Balloon Museum Dr includes three travel lanes.

**Alameda Blvd and San Mateo Blvd** is a four-legged signalized intersection with pedestrian facilities available on all approaches. The north and southbound approaches on San Mateo Blvd have two travel lanes. The eastbound approach on Alameda Blvd has three travel lanes. The westbound approach on Alameda Blvd has two travel lanes and a left turn lane separated by a chevron-striped buffer.

**Alameda Blvd and Southbound Pan American Frontage Rd** is a four-legged, signalized intersection with pedestrian facilities available on all approaches. The Southbound Pan American Frontage Rd is a one-way roadway that leads up to I-25 just south of this intersection. It has four travel lanes up to the

intersection. The eastbound approach on Alameda Blvd has three travel lanes. The westbound approach on Alameda Blvd has four travel lanes.

**Roy Ave / Tramway Blvd and Southbound Pan American Frontage Rd** is a four-legged, signalized intersection with pedestrian facilities available on all approaches. The Southbound Pan American Frontage Rd is a one-way roadway leading up to Alameda Blvd, about 1.3 miles south of this intersection. It has four travel lanes up to the intersection. The eastbound approach on Roy Ave has two travel lanes. The westbound approach on Roy Ave has four travel lanes.

**San Mateo Blvd and Balloon Fiesta Pkwy** is a four-legged, two-way, stop-controlled intersection with pedestrian facilities available at all corners. However, there are no marked crossings.

**Southbound Pan American Frontage Rd and Balloon Fiesta Pkwy** is a three-legged, one-way stop-controlled intersection with pedestrian facilities on the west side of the Southbound Pan American Frontage Rd. The Southbound Pan American Frontage Rd is a one-way roadway with two travel lanes. The eastbound approach on Balloon Fiesta Parkway has one regular travel lane. However, a second lane is striped against use but opened for the Balloon Fiesta to carry event traffic to the Southbound Pan American Frontage Rd to I-25.

### **Transit Service Description**

There is transit service on Alameda Blvd (Route 98) and on Jefferson St and San Diego (Route 140), with two bus stops on San Diego Ave. Route 98 is a commuter route that is currently suspended. Route 140 provides service Monday-Friday, currently during peak hours only, although standard service is every 30 minutes from 6 AM to 6 PM Monday through Friday. For a current map of stops, routes, and frequencies, see <https://abqride-cabq.hub.arcgis.com/>, and for route schedules, see <https://www.cabq.gov/transit/routes-and-schedules>. From ABQ Ride Transit:

*This development would provide better multi-modal access to transit service and the larger area if a sidewalk along San Diego was provided across Tract A to connect to the existing sidewalk on the north side of San Diego Avenue, as well as providing an accessible route between the stadium and San Diego Avenue. This would allow access for pedestrians, bicyclists, and transit users to more safely access this new destination. See IDO Sections 5-3(D)(2)(b) and 5-3(D)(3)(b).*

## **Balloon Fiesta Area Event and Non-Event Data Review**

### **Ballon Fiesta Non-Event Hourly Traffic Profile and Existing Levels of Service**

#### Normal Operations Hourly Traffic Profile

Normal operations, as evaluated here, are based on the turning movement counts collected from a non-event impacted Thursday evening. Balloon Fiesta non-event turning movement count data was collected on October 14, 2021. This assessment considered the data as a point of comparison and relevance based on the location of the proposed stadium. Drivers in the area are familiar with existing traffic patterns and rush hour congestion, making comparison of stadium event traffic to the rush hour operations relatable.

Figure 4 below depicts the hourly profile for the three gateway intersections over six hours from 4 PM to 10 PM.

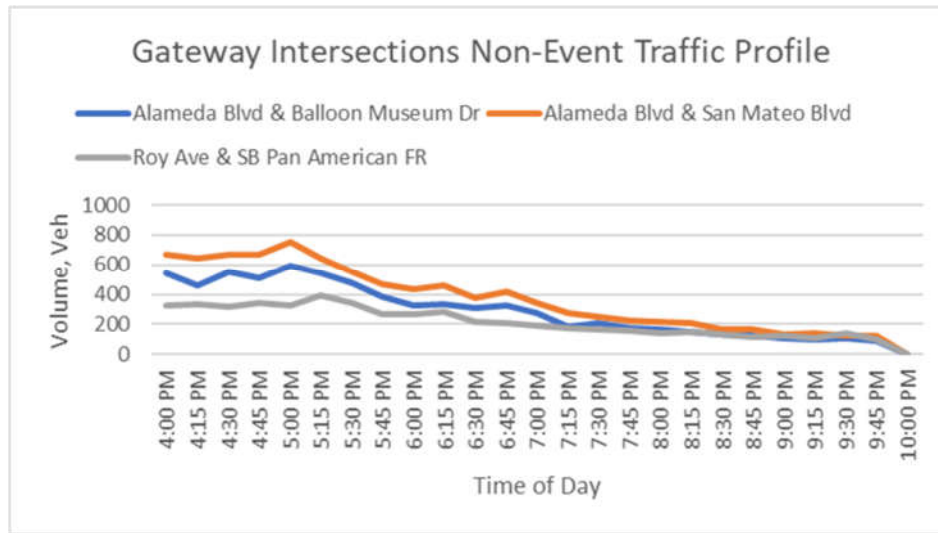

**Figure 4: Gateway Intersections PM Peak Hour Profile**

The non-event hourly traffic profile shows expected roadway trends with high peak hour volumes in the late afternoon and a steady decline in traffic volumes as the evening progresses.

### Existing Levels of Service

Highway Capacity Software (HCS) was used to analyze the study intersections for Level of Service (LOS) and 95<sup>th</sup> percentile queueing conditions. HCS implements methods and procedures detailed by the Highway Capacity Manual (HCM). Per the HCM, LOS is presented as a letter grade (A through F) based on the calculated average delay for an intersection or movement. Delay is calculated as a function of several variables, including signal phasing operations, cycle length, traffic volumes, and opposing traffic volumes, and is a measurement of the average wait time a driver can expect when moving through an intersection. Factors such as total cycle time (for all movements), queueing restrictions, and vehicle volumes can affect measurements of delay, especially for lower-volume movements and side streets. Generally, these factors are only realized when delays reach or exceed LOS E thresholds. Existing levels of service for each intersection were determined by conducting the analysis on the Balloon Fiesta non-event PM peak hour data. The calculated system peak hour is 4:30 PM to 5:30 PM.

Intersection delay and level of service for stop-controlled intersections are reported as the delay and level of service for the worst-case movement at each intersection. Detailed HCS output sheets can be found in Appendix D. Table 1 and Table 2 below, reproduced from the Highway Capacity Manual, show delay thresholds and the associated Level of Service assigned to delay ranges.

**Table 1: LOS Criteria and Descriptions for Signalized Intersections**

Level of Service	Average Control Delay (sec/vehicle)	General Description (Signalized Intersections)
A	≤10	Free flow
B	>10 – 20	Stable flow (slight delays)
C	>20 – 35	Stable flow (acceptable delays)
D	>35 – 55	Approaching unstable flow (tolerable delay, occasionally wait through more than one signal cycle before proceeding)
E	>55 – 80	Unstable flow (intolerable delay)
F	>80	Forced flow (jammed)

**Table 2: LOS Criteria and Descriptions for Unsignalized Intersections**

Level of Service	Average Control Delay (sec/veh)
A	≤10
B	>10 – 15
C	>15 – 25
D	>25 – 35
E	>35 – 50
F	>50

Queue length is reported in feet for the 95<sup>th</sup> percentile queue, with a base assumption of 25 feet of queue length per vehicle. Notably, 95<sup>th</sup> percentile queues are statistically expected to occur during only 5% of the peak hour's signal cycles. The 95th percentile queue is helpful because it shows the maximum queue length likely to be present. The average queue at an intersection would statistically be much shorter than the 95<sup>th</sup> percentile queue.

Figure 5 and Figure 6 detail the peak hour volumes used for the Gateway and Internal intersections laid over an aerial image of the study area. The results of the HCS capacity analysis are detailed in Table 3,

following the volume figures.

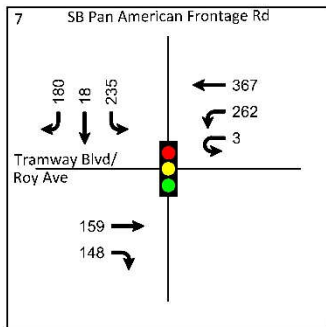
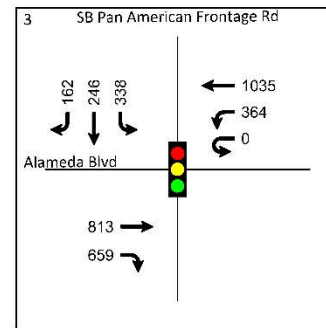
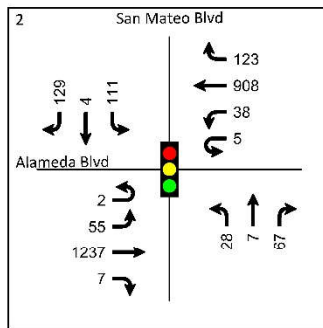
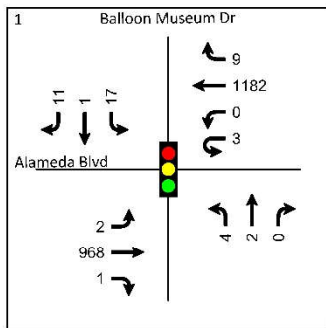
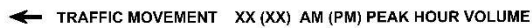
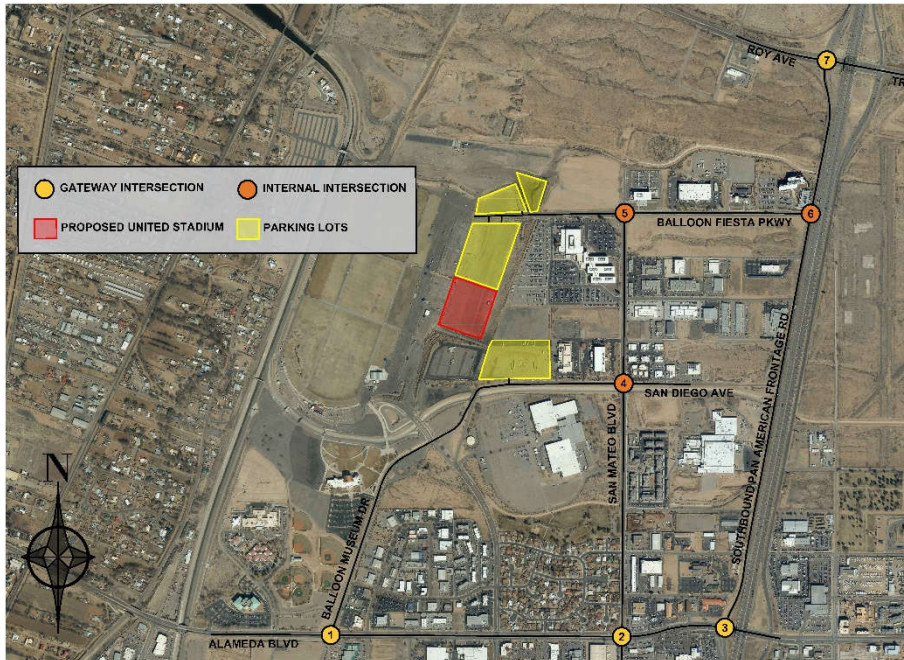

Figure 5: Gateway Intersections PM Peak Hour Volumes



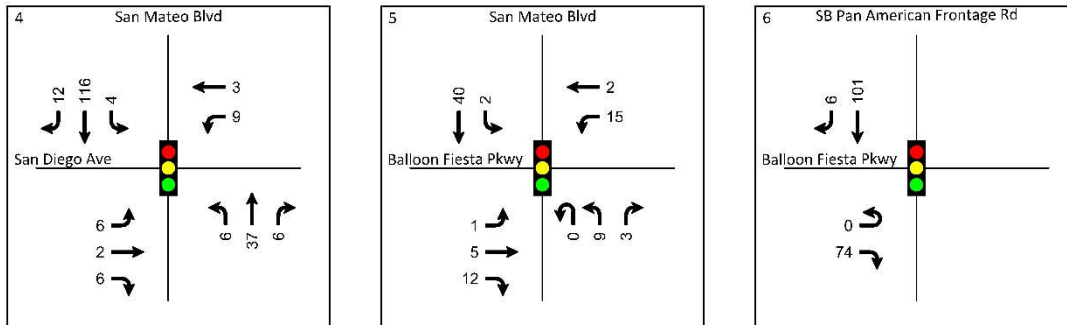
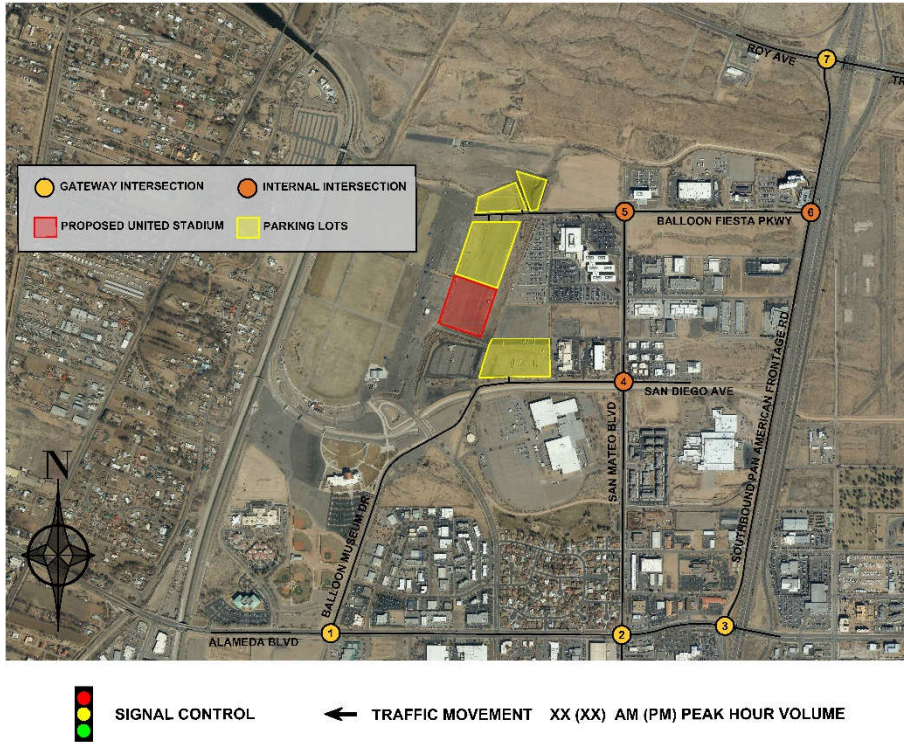

Figure 6: Internal Intersections PM Peak Hour Volumes

**Table 3: PM Peak Hour Capacity Analysis Results Summary**

Gateway Intersections PM Peak Hour						Internal Intersections PM Peak Hour					
Alameda Blvd & Balloon Museum Dr						San Mateo Blvd and San Diego Ave <sup>1</sup>					
Time	Movement	Delay and Level of Service				Time	Movement	Delay and Level of Service			
		95th % (ft)	Delay (s/veh)	LOS	Overall LOS			95th %	Delay (s/veh)	LOS	Overall LOS
4:30PM - 5:30PM	EBL	0.3	2.9	A	A	4:30PM - 5:30PM	EBL				A
	EBT	80.4	2.8	A			EBT	2.5	9.6	A	
	EBR	0.1	1.9	A			EBR				
	WBL	0.0	0.0	A			WBL	0.0	9.7	A	
	WBT	155.3	4.5	A			WBT				
	WBR	155.0	4.5	A			WBR	0.0	10.5	B	
	NBL	6.1	61.6	E			NBL	0.0	7.6	A	
	NBT	0.0	0.0	-			NBT				
	NBR	-	-	-			NBR				
	SBL	24.0	56.5	E			SBL	0.0	7.3	A	
	SBT	1.4	24.5	D			SBT				
	SBR	15.7	55.2	E			SBR				
Alameda Blvd and San Mateo Blvd						San Mateo Blvd and Balloon Fiesta Pkwy <sup>1</sup>					
Time	Movement	Delay and Level of Service				Time	Movement	Delay and Level of Service			
		95th % (ft)	Delay (s/veh)	LOS	Overall LOS			95th %	Delay (s/veh)	LOS	Overall LOS
4:30PM - 5:30PM	EBL	14.4	5.1	A	B	4:30PM - 5:30PM	EBL	0.0	7.2	A	A
	EBT	270.9	8.4	A			EBT				
	EBR	250.6	8.5	A			EBR				
	WBL	10.1	6.1	A			WBL	0.0	7.3	A	
	WBT	212.8	7.5	A			WBT				
	WBR	206.6	7.5	A			WBR				
	NBL	40.3	58.5	E			NBL	0.0	9.6	A	
	NBT	99.1	50.6	D			NBT	0.0	9.4	A	
	NBR	-	-	-			NBR	0.0	8.4	A	
	SBL	163.6	58.4	E			SBL	0.0	9.2	A	
	SBT	186.1	53.2	D			SBT				
	SBR	-	-	-			SBR	0.0	9.7	A	
Alameda Blvd and Southbound Pan American Frontage Rd						Balloon Fiesta Pkwy and Southbound Pan American Frontage Rd <sup>1</sup>					
Time	Movement	Delay and Level of Service				Time	Movement	Delay and Level of Service			
		95th % (ft)	Delay (s/veh)	LOS	Overall LOS			95th % (Veh)	Delay (s/veh)	LOS	Overall LOS
4:30PM - 5:30PM	EBL	-	-	-	C	4:30PM - 5:30PM	EBL				A
	EBT	233.1	12.6	B			EBT				
	EBR	493.8	22.7	C			EBR	7.5	9.0	A	
	WBL	69.2	8.3	A			WBL				
	WBT	210.1	7.4	A			WBT				
	WBR	-	-	-			WBR				
	NBL	-	-	-			NBL				
	NBT	-	-	-			NBT				
	NBR	-	-	-			NBR				
	SBL	664.6	141.2	F			SBL				
	SBT	156.7	45.9	D			SBT				
	SBR	211.1	48.6	D			SBR				
Roy Ave and Southbound Pan American Frontage Rd											
Time	Movement	Delay and Level of Service									
		95th % (ft)	Delay (s/veh)	LOS	Overall LOS						
4:30PM - 5:30PM	EBL	-	-	-	B						
	EBT	51.1	13.3	B							
	EBR	48.8	13.7	B							
	WBL	23.8	8.1	A							
	WBT	30.7	6.3	A							
	WBR	-	-	-							
	NBL	-	-	-							
	NBT	-	-	-							
	NBR	-	-	-							
	SBL	90.9	16.8	B							
	SBT	3.0	14.4	B							
	SBR	68.2	16.4	B							

<sup>1</sup> Stop Controlled Intersection, Overall LOS reported as worst case lane group LOS

From Table 3 above the following observations can be made. The worst overall level of service for Existing conditions is LOS C at the intersection of Alameda Blvd and Southbound Pan American Frontage Rd. The southbound left turn has a delay of 141.2 s/veh at a LOS F.

The Gateway Intersections operate at an overall LOS C or better.

Alameda Blvd and Balloon Museum Dr

- All movements operate at LOS E or better. The NBL, SBL, and SBR movements all operate at LOS E.

Alameda Blvd and San Mateo Blvd

- All movements operate at LOS E or better. The NBL and SBL movements operate at LOS E.

Alameda Blvd and SB Pan American Frontage Rd

- All movements operate at LOS C or better except for the SB lane group, which operates at LOS F or better. The SBL movement operates at LOS F.

Roy Ave / Tramway Blvd and SB Pan American Frontage Rd

- All movements operate at LOS B or better. Balloon Fiesta Event Traffic Operations

The Internal Intersections operate at an overall LOS A.

San Mateo Blvd and San Diego Ave

- All movements operate at LOS B or better

San Mateo Blvd and Balloon Fiesta Pkwy

- All movements operate at LOS A or better

Balloon Fiesta Pkwy and SB Pan American Frontage Rd

- All movements except EBR are unquantifiable as the SB Frontage Rd is a one-way road. The EBR movement operates at LOS A.

## **Ballon Fiesta Event Traffic Operations**

### [Ingress and Egress Processing Rate](#)

Lee Engineering has conducted both event and non-event Traffic Movement Counts (TMCs) within the Balloon Fiesta Park area since 2019. These TMCs were performed at each of the study intersections considered by this evaluation. Extreme weather-related event cancelations during data collection in 2022 resulted in counts that did not conform to the usual traffic patterns exhibited at these locations. Due to this uncertainty in the 2022 data, the TMC results from 2021 were chosen as the most representative and comparable data set. The Balloon Fiesta event data was collected during the event's ingress and egress periods, covering six hours each morning and six hours each night from 4 AM to 10 AM and 4 PM to 10 PM, respectively.

In addition to collecting vehicle count data from Balloon Fiesta Park and the surrounding area, Lee Engineering has extensively reviewed video of Balloon Fiesta ingress and egress, including the traffic



control operations. From those sources, processing rates under event control at the three gateway intersections were determined. During Balloon Fiesta event peak ingress and egress operations, the three gateway intersections are able to process approximately 2,000 vehicles per hour.

### Balloon Fiesta Event Hourly Traffic Profile

The total demand for access through the gateway intersections is approximately 6,000 vehicles entering and leaving the Balloon Fiesta Park area. The ability of the gateway intersection to process 2,000 vehicles per hour results in three-plus hours of ingress traffic flow and the same again for egress traffic flow. Additionally, the balloon Fiesta event start and end times are much more variable, which also results in longer ingress and egress durations than would be accounted for purely by the processing rate. These factors create six congested hours in the morning and evening each day during the Balloon Fiesta. Comparatively, the projected regular United game-generated traffic volumes, as discussed in subsequent sections, either do not exceed the processing capacity of the gateway intersections or do not exceed it by enough to result in remotely comparable congested periods. Figure 7 below shows the Balloon Fiesta traffic profile through the three gateway intersections as captured on October 7, 2021.

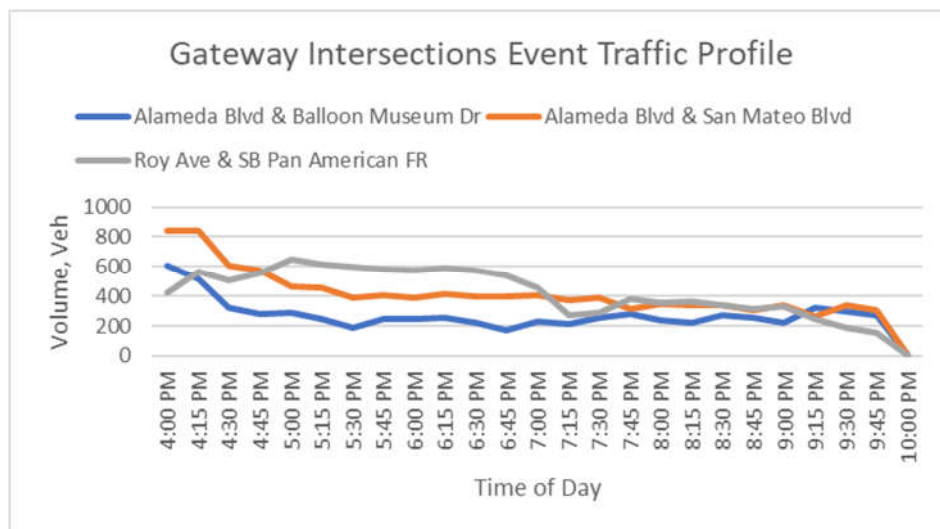

**Figure 7: Balloon Fiesta Event Gateway Intersections Hourly Traffic Profile**

From Figure 7 above, traffic patterns initially appear similar to the Non-event, normal traffic profile. However, from video recorded in conjunction with the collection of TMC data, traffic control operations limit access to Alameda Blvd. These limitations largely remove non-event traffic from the corridor. This means that from approximately 6:00 to 9:30 PM, the profile shown in Figure 7 does not include traffic that would otherwise be present. If normal traffic operations were allowed to continue through the corridor, the combined event and non-event traffic profile above would likely display nearly twice the traffic volumes. The traffic control and traffic rerouting associated with balloon Fiesta events is some of the most intense that occurs in Albuquerque.

### Balloon Fiesta Traffic Control Operations

The traffic control measures implemented for the International Balloon Fiesta are arguably some of the most widespread and intense normally seen within the city of Albuquerque. Alameda Blvd, also NM 528

is a principal arterial and one of only seven corridors with a Rio Grande River crossing in the city. The traffic control plan for the Balloon Fiesta events closes this corridor to normal through traffic from 2<sup>nd</sup> St on the west side of the Balloon Fiesta Park to the Northbound Pan American Frontage Rd during peak ingress and egress operations.

Additionally, the plan calls for the closure of the I-25 southbound exit ramp at Alameda Blvd and restricts access to the southbound Pan American Frontage Rd from Roy Ave to Alameda Blvd down to one roadway. Further, large numbers of police officers and vehicles are deployed throughout the area to the majority of intersections either bordering or within the Balloon Fiesta Park area. Supplementing the heavy police presence is a multitude of traffic control devices, from signs and orange cones to high-intensity mobile lighting platforms. In sum, this is a traffic control effort far in excess of what is likely to be required to safely and efficiently accommodate the traffic generated by the proposed stadium. In the next section, the traffic volumes, ingress and egress traffic distribution, expected traffic, operational performance, and resultant traffic control needs for the proposed stadium are developed and discussed.

## **United Stadium Projected Traffic Operations**

### **Stadium Trip Generation Initial Data**

The New Mexico United Soccer Club was established in 2018 and, since that time, has been sharing a stadium with the Albuquerque Isotopes baseball team. As an existing team, data regarding stamped ticketed attendance and parking usage for United home games were available for this analysis. Lee Engineering obtained the stamped ticket count directly from the United Business Office. These stamped ticket attendance rates differ from ticket sales in that they more accurately represent the number of people in attendance.

Parking used by spectators for current United games is predominately located in the University of New Mexico Athletics-managed parking lots located south and west of the Isotopes Park. Parking usage data for United home games was obtained from UNM Athletics. The number of attendees compared to the number of parked vehicles was then used to determine a Vehicle Occupancy Rate (VOR), a key metric for determining expected passenger vehicle trips the proposed stadium would generate.

The present location of the United games, the Rio Grande Credit Union Field at Isotopes Park, has a comparable spectator capacity to the proposed United stadium at Balloon Fiesta Park. Isotopes Park has 11,124 seats, and the proposed stadium is expected to hold between 10,000 and 12,000 attendees. This study assesses the proposed stadium using the higher-end 12,000-person capacity. The current United attendance data for four games held on July 19, July 22, August 12, and August 23 of 2023 was compared to the Isotopes Park capacity to determine what percentage of that existing capacity was regularly used by United fans. The stamped ticket attendee counts and their associated parking usage are shown in Table 4.

**Table 4: Attendance, Parking, and Vehicle Occupancy Rates for Current United Games**

United Games					
Date	Parked Vehicles	Stamped Attendees	Vehicle Occupancy Rates Without Reduction Factors	Attendees Assumed to Have Arrived By Passenger Vehicle	Vehicle Occupancy Rate
19-Jul	1634	6276	3.8	5962	3.6
22-Jul	2020	7481	3.7	7107	3.5
12-Aug	1602	6567	4.1	6239	3.9
23-Aug	1146	3937	3.4	3740	3.3
Average	1601	6065	3.8	5762	3.6

Data from UNM Athletics Parking Division and United League Business Office collected the week of 8/28

From Table 4, the stamped attendee count divided by the number of parked vehicles gives a VOR without a reduction factor. Traffic Impact Studies for similar facilities applied a reduction factor to attendance counts when calculating a VOR to account for spectators using transportation modes other than passenger vehicles. The alternate modes considered included walking, bicycling, and using public transit.

Several traffic impact studies for similar developments were reviewed to gather non-passenger vehicle travel information. From the review of Traffic Impact Study (TIS) reports from similar developments, a TIS for a multi-use Stadium in Knoxville assumed 10%. The Transportation Management Plan for the DC United stadium assumed that 5% of attendees would walk, use a bike, use a Taxi/Uber, or use a Charter Bus/Other. This area also included a Metrorail, which does not apply to the Balloon Fiesta Park area. The FC Cincinnati West End Stadium Traffic Study assumed that 16% of attendees would use a non-auto mode of transportation. This split included a streetcar, which is not applicable to the Balloon Fiesta Park area. Without the streetcar, the study assumes 6.2%.

Given the location of the proposed United stadium, access to multimodal transportation options is limited. While the study area includes some residential usage, its location on the far northeast side of Albuquerque makes walking a potential transportation option for few attendees. Similarly, CABQ Ride transit operations do not provide service capable of fulfilling the needs of United fans as the current bus route through the area terminates service before the usual United game start time. The proposed site does have suitable access for bicyclists, with a multiuse trail running north/south along the western side of Balloon Fiesta Park. For these reasons, a 5% reduction factor was applied to the stamped attendance counts before determining the VOR used during this study.

With the application of the reduction factor, the United game average VOR is 3.6 persons per vehicle. For comparison, the VOR assumed for planning purposes by the Isotopes Park management is 2.5, and the Up, Up, and Away study conducted by the UNM Civil and Environmental Engineering department estimated the vehicle occupancy rate to be 3.25 for the Balloon Fiesta.

The next step in determining the proposed stadium's trip generation was to establish planning attendance rates for evaluation. As previously stated, the maximum occupancy for Isotopes Park is 11,124, and the average stamped attendance of a United game was 6,065 people. This results in an average occupancy rate of 55% of total capacity. For the purposes of this study, two occupancy rates were chosen for evaluation. The first is for what would be considered an average occupancy event, such as a regular season game with an associated attendance of 60% of the maximum. The second occupancy rate chosen was for a sold-out game, 100% of capacity. The post-reduction factor VOR was then applied

to each attendance rate to produce the associated number of passenger vehicles generated by each. The results of these calculations are presented below in Table 5.

**Table 5: Attendance Rates and Resulting Trip Generation**

Planning Occupancy	Planning Attendance	Estimated Trip Generation (Veh)
60%	7200	1900
100%	12000	3167

### Stadium Trip Distribution

The following presents methods used to determine the stadium's trip generation. The traffic flow to and from the proposed stadium must pass through one of three gateway intersections. Routes through these intersections to the various stadium parking facilities are presented in Figure 3. A gravity model was created to project the percentage of the total number of attendees that arrive via each of the possible routes.

The gravity model estimates the macroscopic relationships between places, e.g., homes and sports stadiums, and provides insights into how trips are likely to flow in a given area. The assumption was that attraction between two TAZs declines with increasing cost, in a trip distribution sense, the distance and/or travel time between them. The gravity model was based on the principle that travelers are less likely to make trips as travel distance increases and assumed trip attraction between two zones is directly proportional to their sizes, i.e., trips produced and attracted and inversely proportional to the distance separating TAZs.

This evaluation used the 2010 Census of 430 TAZs in the greater Albuquerque area, including Albuquerque, Rio Rancho, Bernalillo, Corrales, Placitas, Sandia Pueblo, Kirtland Airforce Base, and Los Ranchos de Albuquerque. The centroid of each TAZ was used to determine the distance between each TAZ. This evaluation used ArcGIS Pro to produce a cost matrix using travel distance as the cost measure because travel time is dynamic and varies widely. Additionally, trip production and attraction are sourced from TAZ estimates available in the Replica Platform. Replica information was used to determine how people and vehicles move within cities and regions by using a composite of data sources to model and simulate travel activity for an area's typical weekday or weekend day. Using an agent-based approach, Replica creates a statistically representative synthetic population using census and marketing data to model travel behavior and activity, such as origin and destination estimates for a given area. Using these data in the gravity model, a trip matrix indicating the estimated number of trips between each pair of TAZs was produced. This matrix serves as input for traffic assignment.

The gravity model's estimations are limited due to its aggregate nature. The gravity model can estimate the choice of many individuals; however, the real-world choices of any given individual can vary greatly from estimates. The estimated trip matrix was then adjusted to ensure consistency with constraints, such as total trips generated and attracted in each TAZ.

The major consideration used by Lee Engineering while adjusting trip arrival percentages at the gateway intersections was the creation of intolerable delay at any single gateway intersection. Given the Balloon Fiesta Park's location on the northern edge of Albuquerque, a heavy skew based on travel distance cost was evident in the Gravity Model. The slightly shorter distance from all points south to the Alameda Blvd

and San Mateo Blvd intersection rather than to the Roy Ave/Tramway Blvd and Southbound Pan American Frontage Rd produced heavy volumes at one and very light volumes at the other. However, this skew creates a delay cost that has a balancing effect on the gateway intersection choice. The following figures display the proposed stadium trip distribution percentages and the resulting traffic volumes added to each ingress or egress lane group.

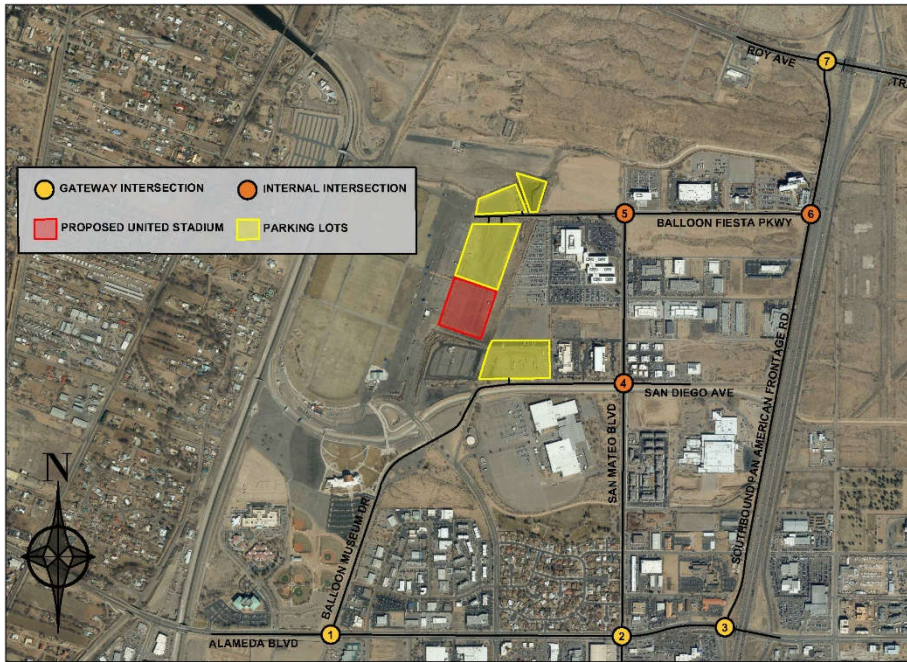

← TRAFFIC MOVEMENT XX (XX) % INGRESS (EGRESS) VOLUME DISTRIBUTION PERCENTAGE

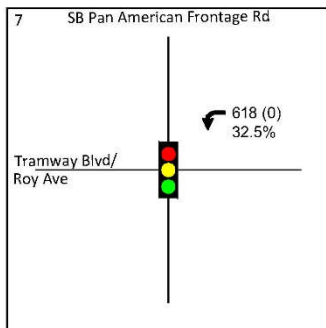
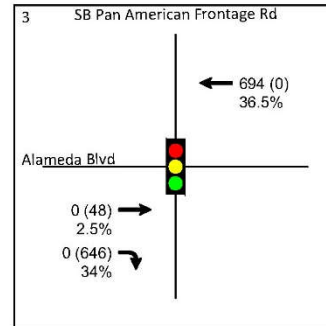
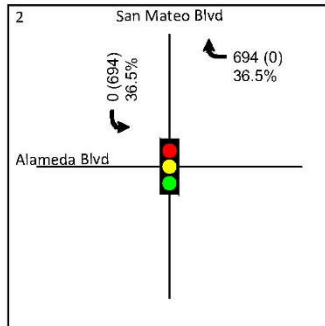
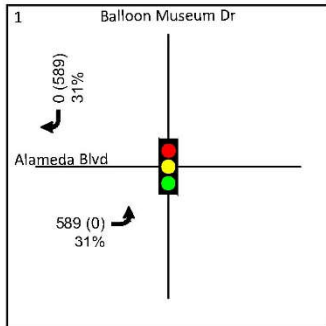

Figure 8: Gateway Intersection Trip Distribution for Average Attendance



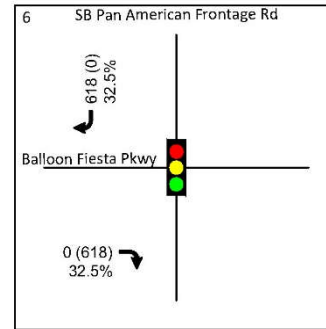
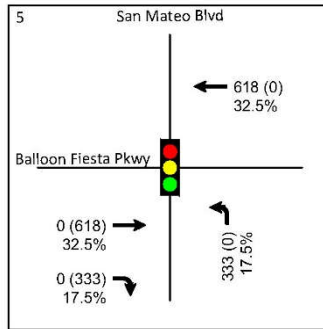
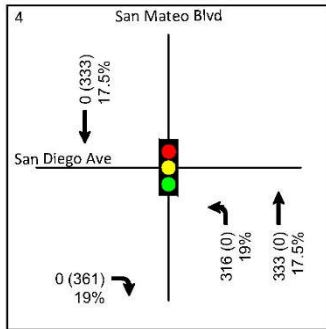
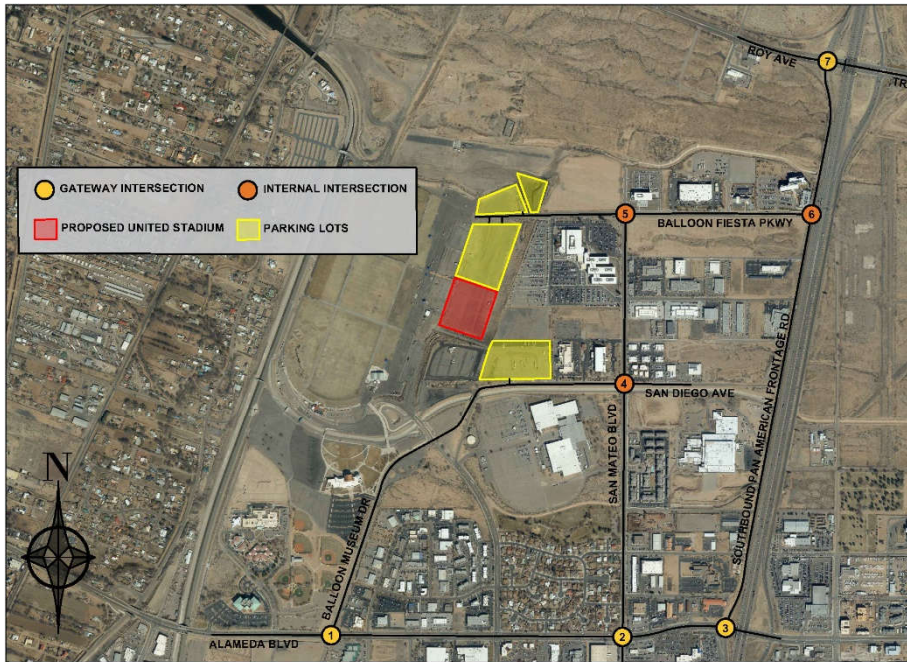
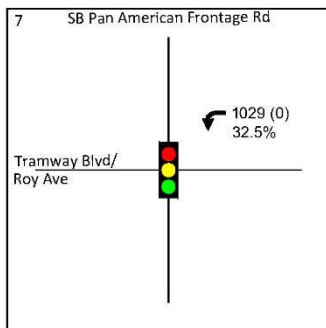
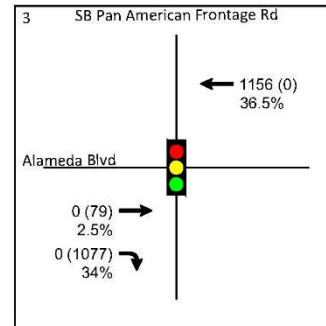
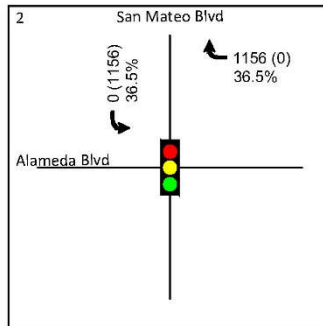
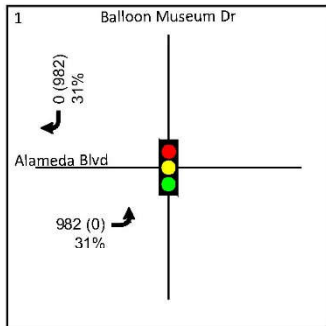

Figure 9: Internal Intersection Trip Distribution for Average Attendance



← **TRAFFIC MOVEMENT XX (XX) % INGRESS (EGRESS) VOLUME DISTRIBUTION PERCENTAGE**



**Figure 10: Gateway Intersection Trip Distribution for Maximum Attendance**



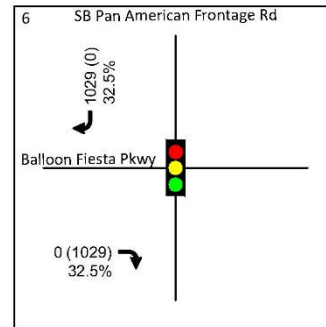
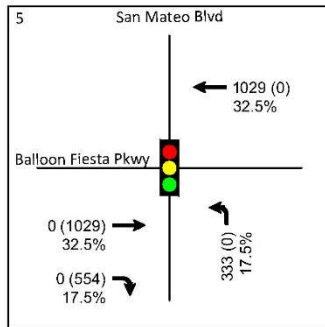
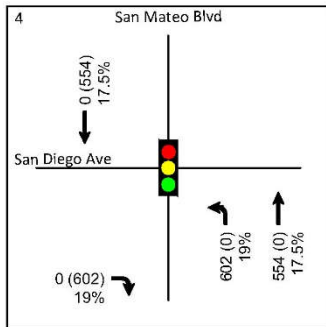
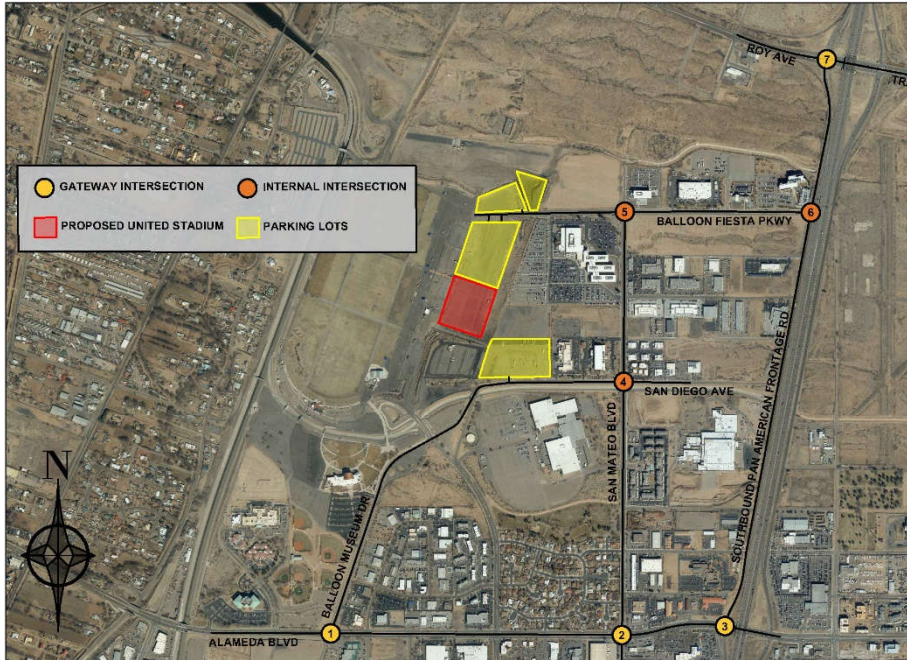
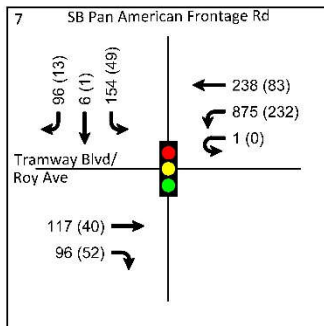
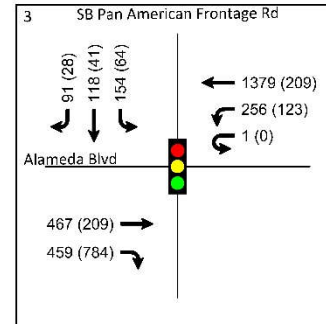
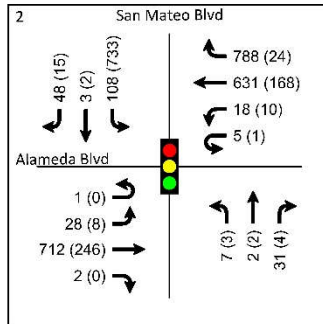
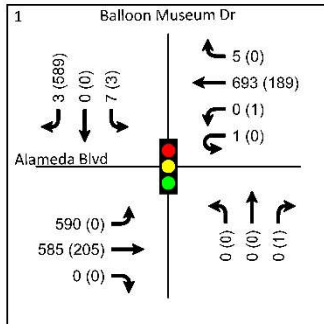
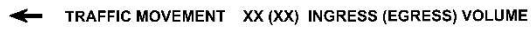

Figure 11: Internal Intersection Trip Distribution for Maximum Attendance

## **Stadium Projected Volumes and Hourly Traffic Profiles**

### Stadium Volumes

The stadium projected volumes determined using the methodology described above are shown in the following figures. The volumes are ingress and egress volumes with the ingress period from 6:00 PM - 7:00 PM and egress at 9:00 PM – 10:00 PM. When added to the background traffic for the same time periods established for the non-event data, the volumes result in the traffic volume profiles displayed in the following figures.



**Figure 12: Gateway Intersections Average Attendance Total Volumes**



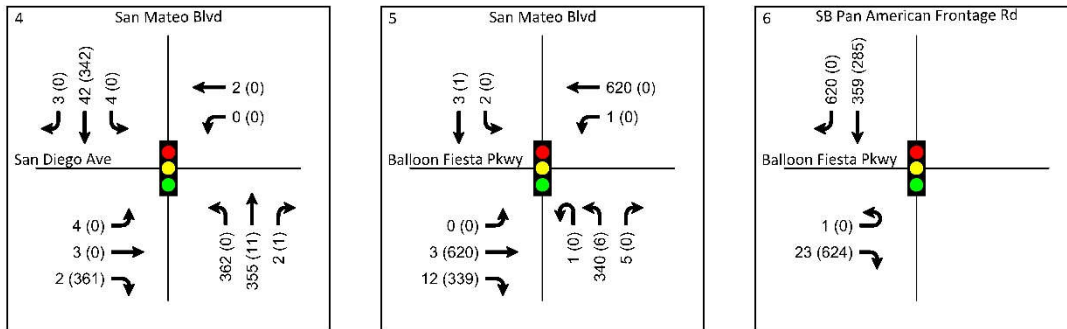
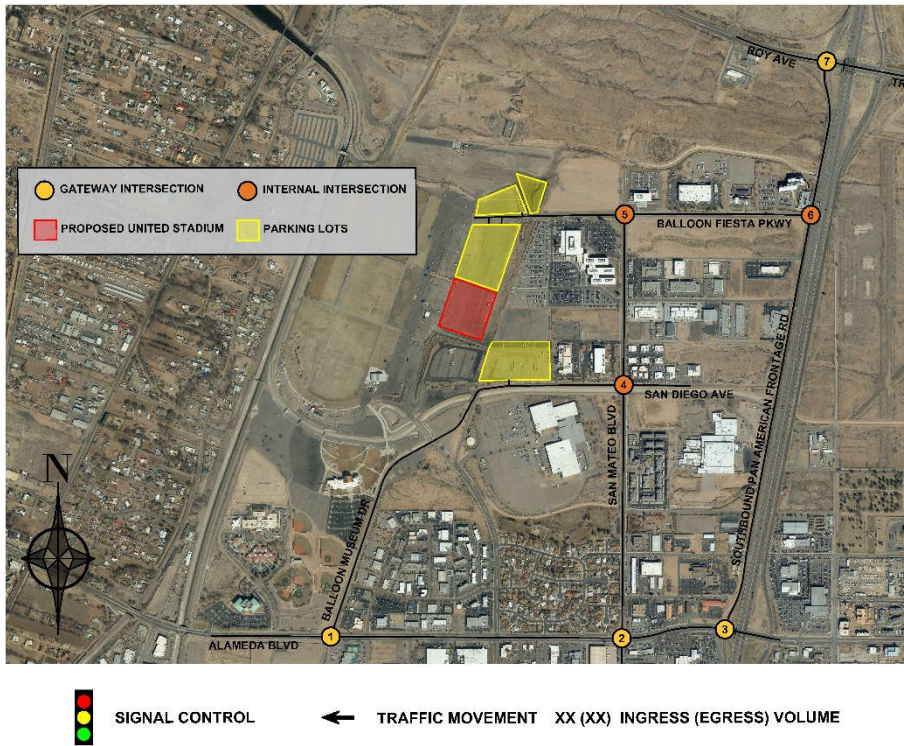

Figure 13: Internal Intersections Average Attendance Total Volumes



SIGNAL CONTROL     
 TRAFFIC MOVEMENT   
 XX (XX) INGRESS (EGRESS) VOLUME

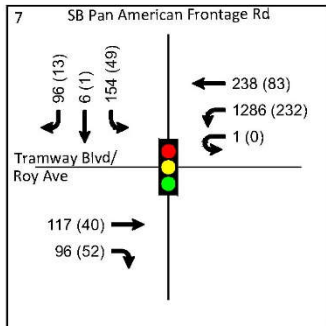
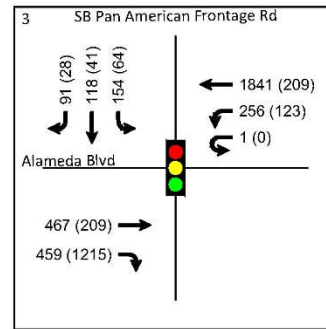
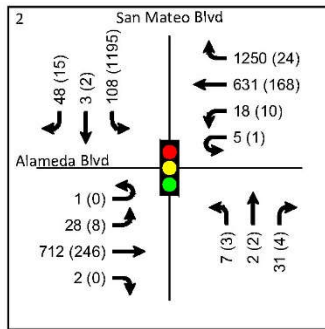
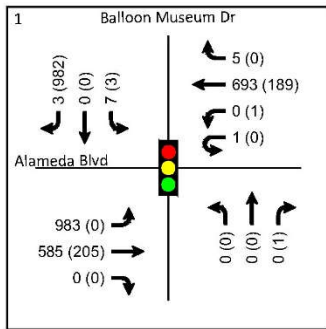

Figure 14: Gateway Intersections Maximum Attendance Total Volumes

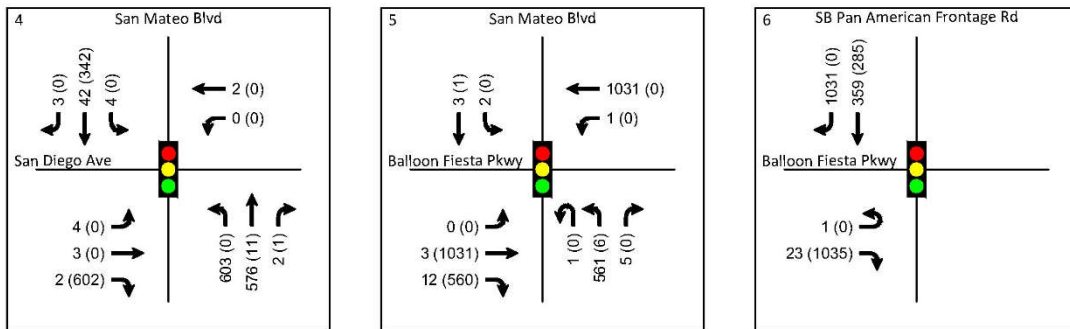
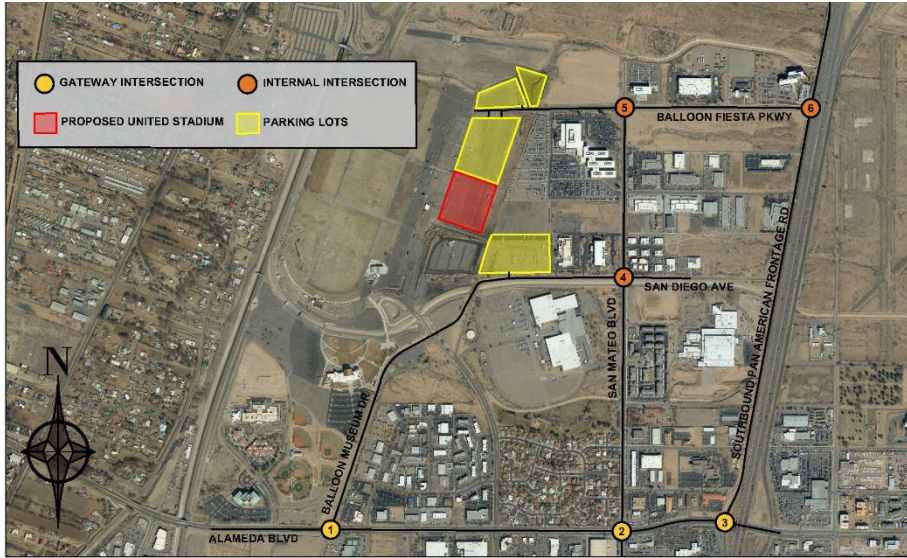

Figure 15: Internal Intersections Maximum Attendance Total Volumes



## Stadium Hourly Traffic Profiles

The average and maximum attendance hourly traffic profiles show similar behavior. Two peaks are expected to occur during the times when United games will impact the surrounding traffic network: one from 6:00 PM to 7:00 PM and another from 9:00 PM to 10:00 PM.

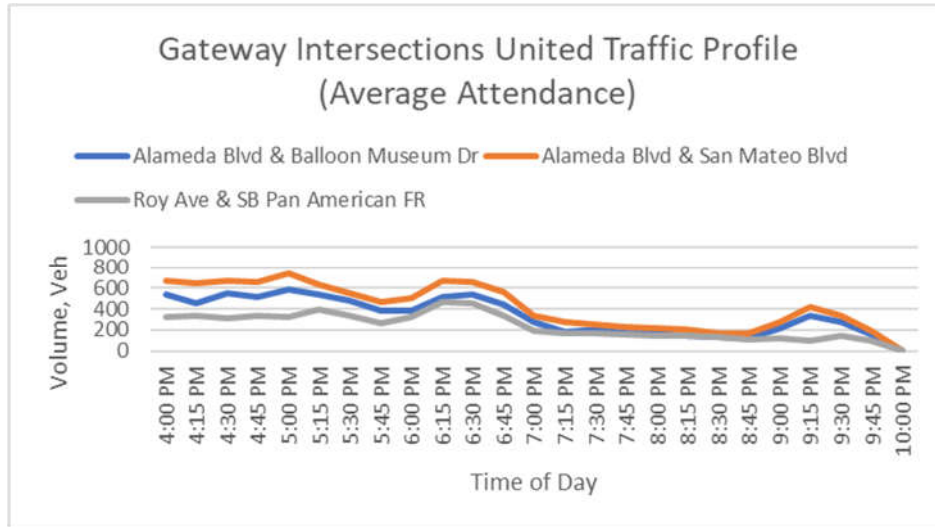

Figure 16: Gateway Intersections United Traffic Profile for Average Attendance

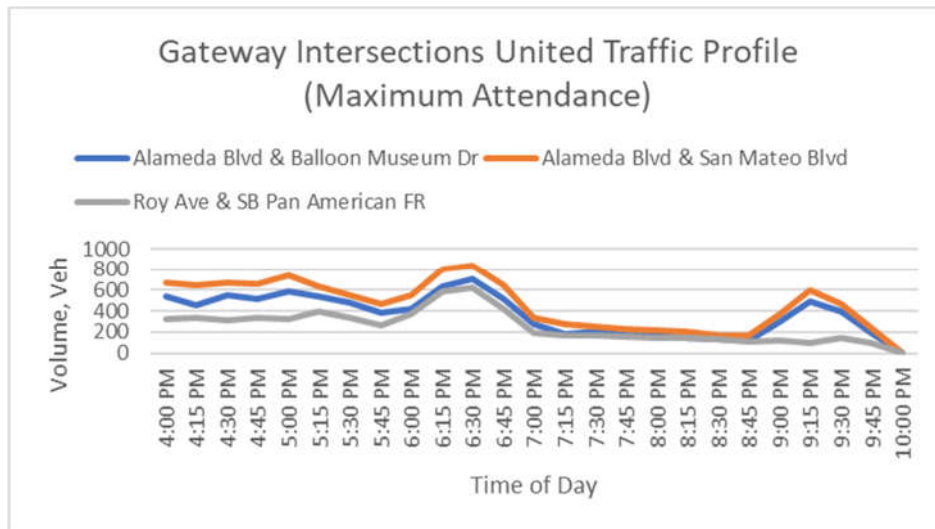

Figure 17: Gateway Intersections United Traffic Profile for Maximum Attendance

From the above figures, it can be noted that an average attendance event traffic would be comparable in traffic volume and intensity with a weekday evening peak hour. The maximum attendance events would exceed the traffic volumes associated with a PM peak hour by approximately 200 vehicles when combined with regular post peak hour traffic.

## **Stadium Ingress and Egress Capacity Analysis**

Tables 6 through 9 below summarize the intersection delay, level of service, and queueing for the average and maximum weekday traffic for the target intersections. Lane groups highlighted in blue show the lane groups that are carrying ingress and egress traffic volumes.



**Table 6: Gateway Intersections Average Attendance Capacity Analysis Results Summary**

Alameda Blvd & Balloon Museum Dr											
Time	Movement	Delay and Level of Service				Time	Movement	Delay and Level of Service			
		95th % (ft)	Delay (s/veh)	LOS	Overall LOS			95th % (ft)	Delay (s/veh)	LOS	Overall LOS
Ingress	EBL	27.6	3.1	A	A	Egress	EBL	< 1 Veh	0.0	---	F
	EBT	< 1 Veh	0.9	A			EBT	49.0	9.5	A	
	EBR	< 1 Veh	0.0	---			EBR	< 1 Veh	0.0	---	
	WBL	< 1 Veh	0.0	---			WBL	< 1 Veh	8.2	A	
	WBT	81.5	3.8	A			WBT	40.4	8.1	A	
	WBR	81.7	3.8	A			WBR	< 1 Veh	---	---	
	NBL	< 1 Veh	0.0	---			NBL	< 1 Veh	0.0	---	
	NBT	< 1 Veh	---	---			NBT	< 1 Veh	39.1	D	
	NBR	---	---	---			NBR	---	---	---	
	SBL	< 1 Veh	63.5	E			SBL	< 1 Veh	37.0	D	
SBT	< 1 Veh	0.0	---	SBT	< 1 Veh	0.0	---				
SBR	< 1 Veh	64.8	E	SBR	3595.0	48.3	F				
Alameda Blvd and San Mateo Blvd											
Time	Movement	Delay and Level of Service				Time	Movement	Delay and Level of Service			
		95th % (ft)	Delay (s/veh)	LOS	Overall LOS			95th % (ft)	Delay (s/veh)	LOS	Overall LOS
Ingress	EBL	< 1 Veh	7.0	A	B	Egress	EBL	< 1 Veh	6.0	A	F
	EBT	110.8	4.9	A			EBT	46.0	6.7	A	
	EBR	100.8	4.9	A			EBR	< 1 Veh	---	---	
	WBL	< 1 Veh	3.7	A			WBL	< 1 Veh	5.9	A	
	WBT	221.9	6.5	A			WBT	36.0	6.5	A	
	WBR	338.0	9.8	A			WBR	35.6	6.5	A	
	NBL	< 1 Veh	54.9	D			NBL	< 1 Veh	43.8	D	
	NBT	44.6	52.5	D			NBT	< 1 Veh	43.0	D	
	NBR	---	---	---			NBR	---	---	---	
	SBL	159.8	58.9	E			SBL	7996.1	2373.0	F	
SBT	69.9	53.2	D	SBT	< 1 Veh	43.3	D				
SBR	---	---	---	SBR	---	---	---				
Alameda Blvd and Southbound Pan American Frontage Rd											
Time	Movement	Delay and Level of Service				Time	Movement	Delay and Level of Service			
		95th % (ft)	Delay (s/veh)	LOS	Overall LOS			95th % (ft)	Delay (s/veh)	LOS	Overall LOS
Ingress	EBL	---	---	---	B	Egress	EBL	---	---	---	B
	EBT	79.8	5.8	A			EBT	< 1 Veh	3.4	A	
	EBR	206.3	8.6	A			EBR	335.7	10.4	B	
	WBL	27.9	3.7	A			WBL	< 1 Veh	2.3	A	
	WBT	179.0	4.4	A			WBT	< 1 Veh	1.6	A	
	WBR	---	---	---			WBR	---	---	---	
	NBL	---	---	---			NBL	---	---	---	
	NBT	---	---	---			NBT	---	---	---	
	NBR	---	---	---			NBR	---	---	---	
	SBL	221.6	60.6	E			SBL	95.0	61.2	E	
SBT	81.2	54.1	D	SBT	29.1	58.1	E				
SBR	130.1	56.4	E	SBR	40.5	58.9	E				
Roy Ave / Tramway Blvd and Southbound Pan American Frontage Rd											
Time	Movement	Delay and Level of Service				Time	Movement	Delay and Level of Service			
		95th % (ft)	Delay (s/veh)	LOS	Overall LOS			95th % (ft)	Delay (s/veh)	LOS	Overall LOS
Ingress	EBL	---	---	---	B	Egress	EBL	---	---	---	A
	EBT	42.2	14.9	B			EBT	< 1 Veh	9.6	A	
	EBR	35.9	15.0	B			EBR	< 1 Veh	9.8	A	
	WBL	97.0	8.7	A			WBL	< 1 Veh	4.8	A	
	WBT	< 1 Veh	5.5	A			WBT	< 1 Veh	3.7	A	
	WBR	---	---	---			WBR	---	---	---	
	NBL	---	---	---			NBL	---	---	---	
	NBT	---	---	---			NBT	---	---	---	
	NBR	---	---	---			NBR	---	---	---	
	SBL	65.1	18.0	B			SBL	< 1 Veh	16.6	B	
SBT	< 1 Veh	16.3	B	SBT	< 1 Veh	16.0	B				
SBR	39.5	17.5	B	SBR	< 1 Veh	16.2	B				

<sup>1</sup>Stop Controlled Intersection, Overall LOS reported as worst case lane group LOS

Alameda Blvd & Balloon Museum Dr

- Weekday Average Attendance
  - EBL ingress lane group operates at LOS A. The SB non—event movements are operating at LOS E due to signal delay rather than capacity issues, and all other lane groups operate at LOS A.
  - The SBR egress movement operates at LOS F with 48.3 seconds of delay and a 95<sup>th</sup> percentile queue length of 3595.0 feet or approximately 144 vehicles. All other movements operate at LOS D or better.
    - Special Egress Timing or Officer Control will be required.

#### Alameda & San Mateo

- Weekday Average Attendance
  - The WBR Ingress movement operates at LOS A.
    - The SBL, a non-ingress movement, operates at LOS E due to signal delay coupled with low side street volumes and not capacity issues.
  - Egress Fails with queue exceeding storage (3K+FT). Will require officer control for egress.
    - Reallocation of green time to simulate officer control that maintains a delay consistent with LOS D for all lane groups results in a 900-1000 foot queue (38 vehicles) for the SB San Mateo egress lane group with an egress movement delay of <40s at the intersection.

#### Alameda & SB Frontage

- Weekday Average Attendance
  - Ingress lane group operates at LOS A. The SB movements do not carry ingress traffic and are operating at LOS E due to signal delay and not capacity.
  - Egress lane groups operate at LOS B or better. The SB movements do not carry planned egress traffic and are operating at LOS E due to signal delay and not capacity related issues.

Roy/Tramway & SB Frontage (Signal administered by the county, and signal timing was obtained via video recording of PM field operations.

- Weekday Average Attendance
  - Ingress lane group operates at LOS A. All lane groups operate at LOS B or better due to low background traffic levels and dual auxiliary lane storage capacity for the ingress WBL movement.
  - There are no egress-related movements at this intersection. All lane groups operate at LOS B or better.

**Table 7: Internal Intersections Average Attendance Capacity Analysis Results Summary**

San Mateo Blvd and San Diego Ave <sup>1</sup>											
Time	Movement	Delay and Level of Service				Time	Movement	Delay and Level of Service			
		95th % (veh)	Delay (s/veh)	LOS	Overall LOS			95th % (veh)	Delay (s/veh)	LOS	Overall LOS
Ingress	EBL	---	---	---	E	Egress	EBL	---	---	---	E
	EBT	< 1 Veh	30.7	D			EBT	11.4	41.6	E	
	EBR	---	---	---			EBR	---	---	---	
	WBL	< 1 Veh	38.8	E			WBL	0.0	10.2	B	
	WBT	---	---	---			WBT	---	---	---	
	WBR	< 1 Veh	40.6	E			WBR	---	---	---	
	NBL	1.2	8.3	A			NBL	0.0	8.2	A	
	NBT	---	0.6	A			NBT	---	0.0	A	
	NBR	---	---	---			NBR	---	---	---	
	SBL	< 1 Veh	8.2	A			SBL	0.0	7.3	A	
	SBT	---	0.0	A			SBT	---	0.0	A	
SBR	---	---	---	SBR	---	---	---				
San Mateo Blvd and Balloon Fiesta Pkwy <sup>1</sup>											
Time	Movement	Delay and Level of Service				Time	Movement	Delay and Level of Service			
		95th % (veh)	Delay (s/veh)	LOS	Overall LOS			95th % (veh)	Delay (s/veh)	LOS	Overall LOS
Ingress	EBL	< 1 Veh	9.2	A	D	Egress	EBL	< 1 Veh	7.2	A	C
	EBT	---	0.0	A			EBT	---	0.0	A	
	EBR	---	---	---			EBR	---	---	---	
	WBL	< 1 Veh	7.3	A			WBL	< 1 Veh	11.1	B	
	WBT	---	0.0	A			WBT	---	---	---	
	WBR	---	---	---			WBR	---	---	---	
	NBL	8.1	30.8	D			NBL	< 1 Veh	20.0	C	
	NBT	< 1 Veh	15.9	C			NBT	< 1 Veh	19.0	C	
	NBR	< 1 Veh	8.4	A			NBR	< 1 Veh	13.0	B	
	SBL	< 1 Veh	16.0	C			SBL	< 1 Veh	13.7	B	
	SBT	---	---	---			SBT	---	---	---	
SBR	< 1 Veh	16.1	C	SBR	< 1 Veh	23.9	C				
Balloon Fiesta Pkwy and Southbound Pan American Frontage Rd <sup>1</sup>											
Time	Movement	Delay and Level of Service				Time	Movement	Delay and Level of Service			
		95th % (veh)	Delay (s/veh)	LOS	Overall LOS			95th % (veh)	Delay (s/veh)	LOS	Overall LOS
Ingress	EBL	---	---	---	A	Egress	EBL	---	---	---	E
	EBT	---	---	---			EBT	---	---	---	
	EBR	< 1 Veh	9.8	A			EBR	18.2	41.0	E	
	WBL	---	---	---			WBL	---	---	---	
	WBT	---	---	---			WBT	---	---	---	
	WBR	---	---	---			WBR	---	---	---	
	NBL	---	---	---			NBL	---	---	---	
	NBT	---	---	---			NBT	---	---	---	
	NBR	---	---	---			NBR	---	---	---	
	SBL	---	---	---			SBL	---	---	---	
	SBT	---	---	---			SBT	---	---	---	
SBR	---	---	---	SBR	---	---	---				

<sup>1</sup> Stop Controlled Intersection, Overall LOS reported as worst case lane group LOS

## San Mateo and San Diego

- Weekday Average Attendance
  - Ingress movements at this two-way stop-controlled intersection are not subject to stop control and operate at LOS A. The EB & WB lane groups carry low volumes and operate at LOS D and E, respectively.
  - Egress movements at the intersection are both SBT and EBR. The SB movements operate at LOS A as they are not stop-controlled. The egress SB right-turn movement does not have a quantifiable LOS because it is an uncontrolled movement.

## San Mateo & Balloon Fiesta Pkwy

- Weekday Average Attendance
  - Ingress traffic flows from the Roy Ave and SB Frontage Rd and San Mateo Ave and Alameda Blvd gateway intersections converge at this intersection with in-flow traffic progressing WBT and NBL. The WBT is not stop-controlled and operates at a LOS A. The NBL movement operates at LOS D with 30.8 seconds and a 95<sup>th</sup> percentile queue of eight vehicles.
  - Egress traffic flows EBT and EBR with minimal background volumes in any other direction. EB flow is not stop-controlled and has a LOS of A. All other lane groups operate at LOS C or better.

## Balloon Fiesta Pkwy & SB Frontage

- Weekday Average Attendance
  - Ingress SB right-turn movement does not have a quantifiable LOS because it is an uncontrolled movement. The EB right-turn background volumes are very low and experience a LOS of A.
  - Egress EBR movement using the existing single lane operates at LOS E with 41 seconds of associated delay. Expanding the egress capacity with the additional available expansion lane and implementing officer control would likely adequately accommodate the egress flow.



**Table 8: Gateway Intersections Maximum Attendance Capacity Analysis Results Summary**

Alameda Blvd & Balloon Museum Dr											
Time	Movement	Delay and Level of Service				Time	Movement	Delay and Level of Service			
		95th % (ft)	Delay (s/veh)	LOS	Overall LOS			95th % (ft)	Delay (s/veh)	LOS	Overall LOS
Ingress	EBL	1712.8	128.1	F	E	Egress	EBL	< 1 Veh	0.0	---	F
	EBT	< 1 Veh	0.9	A			EBT	49.0	9.5	A	
	EBR	< 1 Veh	0.0	---			EBR	< 1 Veh	0.0	---	
	WBL	< 1 Veh	0.0	---			WBL	< 1 Veh	8.2	A	
	WBT	209.1	13.1	B			WBT	40.4	8.1	A	
	WBR	209.1	13.1	B			WBR	< 1 Veh	---	---	
	NBL	< 1 Veh	0.0	---			NBL	< 1 Veh	0.0	---	
	NBT	< 1 Veh	---	---			NBT	< 1 Veh	39.1	D	
	NBR	---	---	---			NBR	---	---	---	
	SBL	< 1 Veh	63.5	E			SBL	< 1 Veh	37.0	D	
SBT	< 1 Veh	0.0	---	SBT	< 1 Veh	0.0	---				
SBR	< 1 Veh	64.8	E	SBR	11162.0	2515.8	F				
Alameda Blvd and San Mateo Blvd											
Time	Movement	Delay and Level of Service				Time	Movement	Delay and Level of Service			
		95th % (ft)	Delay (s/veh)	LOS	Overall LOS			95th % (ft)	Delay (s/veh)	LOS	Overall LOS
Ingress	EBL	31.1	41.9	D	D	Egress	EBL	< 1 Veh	6.0	A	F
	EBT	110.8	4.9	A			EBT	46.0	6.7	A	
	EBR	100.8	4.9	A			EBR	< 1 Veh	---	---	
	WBL	< 1 Veh	3.7	A			WBL	< 1 Veh	5.9	A	
	WBT	221.9	6.5	A			WBT	36.0	6.5	A	
	WBR	1581.2	87.1	F			WBR	35.6	6.5	A	
	NBL	< 1 Veh	54.9	D			NBL	< 1 Veh	43.8	D	
	NBT	44.6	52.5	D			NBT	< 1 Veh	43.0	D	
	NBR	---	---	---			NBR	---	---	---	
	SBL	159.8	58.9	E			SBL	16421.0	4959.9	F	
SBT	69.9	53.2	D	SBT	< 1 Veh	43.3	D				
SBR	---	---	---	SBR	---	---	---				
Alameda Blvd and Southbound Pan American Frontage Rd											
Time	Movement	Delay and Level of Service				Time	Movement	Delay and Level of Service			
		95th % (ft)	Delay (s/veh)	LOS	Overall LOS			95th % (ft)	Delay (s/veh)	LOS	Overall LOS
Ingress	EBL	---	---	---	B	Egress	EBL	---	---	---	F
	EBT	79.8	5.8	A			EBT	50.7	7.9	A	
	EBR	206.3	8.6	A			EBR	15016.6	1385.0	F	
	WBL	27.9	3.7	A			WBL	< 1 Veh	5.9	A	
	WBT	436.5	9.0	A			WBT	30.5	4.8	A	
	WBR	---	---	---			WBR	---	---	---	
	NBL	---	---	---			NBL	---	---	---	
	NBT	---	---	---			NBT	---	---	---	
	NBR	---	---	---			NBR	---	---	---	
	SBL	221.6	60.6	E			SBL	< 1 Veh	46.2	D	
SBT	81.2	54.1	D	SBT	< 1 Veh	68.9	E				
SBR	130.1	56.4	E	SBR	< 1 Veh	45.3	D				
Roy Ave / Tramway Blvd and Southbound Pan American Frontage Rd											
Time	Movement	Delay and Level of Service				Time	Movement	Delay and Level of Service			
		95th % (ft)	Delay (s/veh)	LOS	Overall LOS			95th % (ft)	Delay (s/veh)	LOS	Overall LOS
Ingress	EBL	---	---	---	B	Egress	EBL	---	---	---	A
	EBT	53.6	18.5	B			EBT	< 1 Veh	9.6	A	
	EBR	45.5	18.7	B			EBR	< 1 Veh	9.8	A	
	WBL	170.8	9.4	A			WBL	< 1 Veh	4.8	A	
	WBT	< 1 Veh	4.9	A			WBT	< 1 Veh	3.7	A	
	WBR	---	---	---			WBR	---	---	---	
	NBL	---	---	---			NBL	---	---	---	
	NBT	---	---	---			NBT	---	---	---	
	NBR	---	---	---			NBR	---	---	---	
	SBL	80.4	21.8	C			SBL	< 1 Veh	16.6	B	
SBT	< 1 Veh	19.8	B	SBT	< 1 Veh	16.0	B				
SBR	48.6	212.0	C	SBR	< 1 Veh	16.2	B				

<sup>1</sup> Stop Controlled Intersection, Overall LOS reported as worst case lane group LOS

#### Alameda Blvd & Balloon Museum Dr

- Average Weekday Attendance
  - EBL ingress lane group operates at LOS A. The SB non-event movements are operating at LOS E due to signal delay rather than capacity issues, and all other lane groups operate at LOS A.
  - The SBR egress movement operates at LOS F with 48.3 seconds of delay and a 95<sup>th</sup> percentile queue length of 3595.0 feet or approximately 144 vehicles. All other movements operate at LOS D or better.
    - Special Egress Timing or Officer Control will be required.

#### Alameda Blvd & San Mateo Blvd

- Average Weekday Attendance
  - The WBR Ingress movement operates at LOS A.
    - The SBL, a non-ingress movement, operates at LOS E due to signal delay coupled with low side street volumes and not capacity issues.
  - Egress Fails with queue exceeding storage (2K+FT). Will require officer control for egress.
    - Reallocation of green time to maintain delays consistent with LOS D for all lane groups results in a 900-1000 foot queue (38 vehicles) for the SB San Mateo Blvd egress lane group with an egress movement delay of less than 40 seconds at the intersection.

#### Alameda Blvd & SB Pan American Frontage Rd

- Weekday Average Attendance
  - Ingress lane group operates at LOS B. The SB movements do not carry ingress traffic and are operating at LOS E due to signal delay rather than capacity issues.
  - Egress lane groups operate at LOS B or better. The SB movements do not carry planned egress traffic and are operating at LOS E due to signal delay rather than capacity issues.

Roy Ave /Tramway Blvd & SB Pan American Frontage Rd (Signal administered by the county, and signal timing was obtained via video recording of PM field operations.)

- Weekday Average Attendance
  - Ingress lane group operates at LOS A. All lane groups operate at LOS B or better due to low background traffic levels and dual auxiliary lane storage capacity for the ingress WBL movement.
  - There are no egress-related movements at this intersection. All lane groups operate at LOS B or better.

**Table 9: Internal Intersections Maximum Attendance Capacity Analysis Results Summary**

San Mateo Blvd and San Diego Ave <sup>1</sup>											
Time	Movement	Delay and Level of Service				Time	Movement	Delay and Level of Service			
		95th % (veh)	Delay (s/veh)	LOS	Overall LOS			95th % (veh)	Delay (s/veh)	LOS	Overall LOS
Ingress	EBL	---	---	---	F	Egress	EBL	---	---	---	F
	EBT	1.3	159.4	F			EBT	186.6	1824.1	F	
	EBR	---	---	---			EBR	---	---	---	
	WBL	< 1 Veh	172.9	F			WBL	< 1 Veh	11.2	B	
	WBT	---	---	---			WBT	---	---	---	
	WBR	< 1 Veh	183.5	F			WBR	---	---	---	
	NBL	2.7	9.4	A			NBL	< 1 Veh	9.0	A	
	NBT	---	1.1	A			NBT	---	0.0	A	
	NBR	---	---	---			NBR	---	---	---	
	SBL	< 1 Veh	9.1	A			SBL	< 1 Veh	7.3	A	
SBT	---	0.0	A	SBT	---	0.0	A				
SBR	---	---	---	SBR	---	---	---				
San Mateo Blvd and Balloon Fiesta Pkwy <sup>1</sup>											
Time	Movement	Delay and Level of Service				Time	Movement	Delay and Level of Service			
		95th % (veh)	Delay (s/veh)	LOS	Overall LOS			95th % (veh)	Delay (s/veh)	LOS	Overall LOS
Ingress	EBL	< 1 Veh	11.5	B	F	Egress	EBL	< 1 Veh	7.2	A	F
	EBT	---	0.0	A			EBT	---	0.0	A	
	EBR	---	---	---			EBR	---	---	---	
	WBL	< 1 Veh	7.3	A			WBL	< 1 Veh	17.0	C	
	WBT	---	0.0	A			WBT	---	---	---	
	WBR	---	---	---			WBR	---	---	---	
	NBL	153.3	1415.6	F			NBL	< 1 Veh	29.8	D	
	NBT	< 1 Veh	26.3	D			NBT	< 1 Veh	27.6	D	
	NBR	< 1 Veh	8.4	A			NBR	< 1 Veh	19.1	C	
	SBL	< 1 Veh	27.3	D			SBL	< 1 Veh	19.6	C	
SBT	---	---	---	SBT	---	---	---				
SBR	< 1 Veh	27.0	D	SBR	< 1 Veh	60.5	F				
Balloon Fiesta Pkwy and Southbound Pan American Frontage Rd <sup>1</sup>											
Time	Movement	Delay and Level of Service				Time	Movement	Delay and Level of Service			
		95th % (veh)	Delay (s/veh)	LOS	Overall LOS			95th % (veh)	Delay (s/veh)	LOS	Overall LOS
Ingress	EBL	---	---	---	A	Egress	EBL	---	---	---	F
	EBT	---	---	---			EBT	---	---	---	
	EBR	< 1 Veh	9.8	A			EBR	212.8	897.7	F	
	WBL	---	---	---			WBL	---	---	---	
	WBT	---	---	---			WBT	---	---	---	
	WBR	---	---	---			WBR	---	---	---	
	NBL	---	---	---			NBL	---	---	---	
	NBT	---	---	---			NBT	---	---	---	
	NBR	---	---	---			NBR	---	---	---	
	SBL	---	---	---			SBL	---	---	---	
SBT	---	---	---	SBT	---	---	---				
SBR	---	---	---	SBR	---	---	---				

<sup>1</sup> Stop Controlled Intersection, Overall LOS reported as worst case lane group LOS

### San Mateo Blvd and San Diego Ave

- Weekday Average Attendance
  - Ingress movements at this two-way stop-controlled intersection are not subject to stop control and operate at LOS A. The EB and WB lane groups carry low volumes and operate at LOS D and E, respectively.
  - All lane groups operate at LOS E or better. The egress movements at the intersection are both SBT and EBR. The SB movements operate at LOS A as they are not stop-controlled. The egress SB right-turn movement does not have a quantifiable LOS because it is an uncontrolled movement. The EBT movement operates at LOS E.

### San Mateo Blvd & Balloon Fiesta Pkwy

- Weekday Average Attendance
  - Ingress traffic flows from the Roy Ave and SB Pan American Frontage Rd and San Mateo Blvd and Alameda Blvd gateway intersections converge at this intersection with ingress-flow converging as WBT and NBL movements. The WBT is not stop-controlled and operates at a LOS A. The NBL movement operates at LOS D.
  - Egress traffic flows EBT and EBR with minimal background volumes in any other direction. EB flow is not stop-controlled and has a LOS of A. All other lane groups operate at LOS C or better.

### Balloon Fiesta Pkwy & SB Pan American Frontage Rd

- Weekday Average Attendance
  - Ingress SB right-turn movement does not have a quantifiable LOS because it is an uncontrolled movement. The EB right-turn background volumes are very low and experience a LOS of A.
  - Egress EBR movement using the existing single lane operates at LOS E. Expanding the egress capacity with the additional available expansion lane and implementing officer control would likely adequately accommodate the egress flow.

### **Stadium and Balloon Fiesta Hourly Traffic Profile Comparison**

The figures below show the PM peak hour and stadium event traffic volume profiles at the gateway intersections. These figures have been previously presented and are reproduced here for ready comparison.



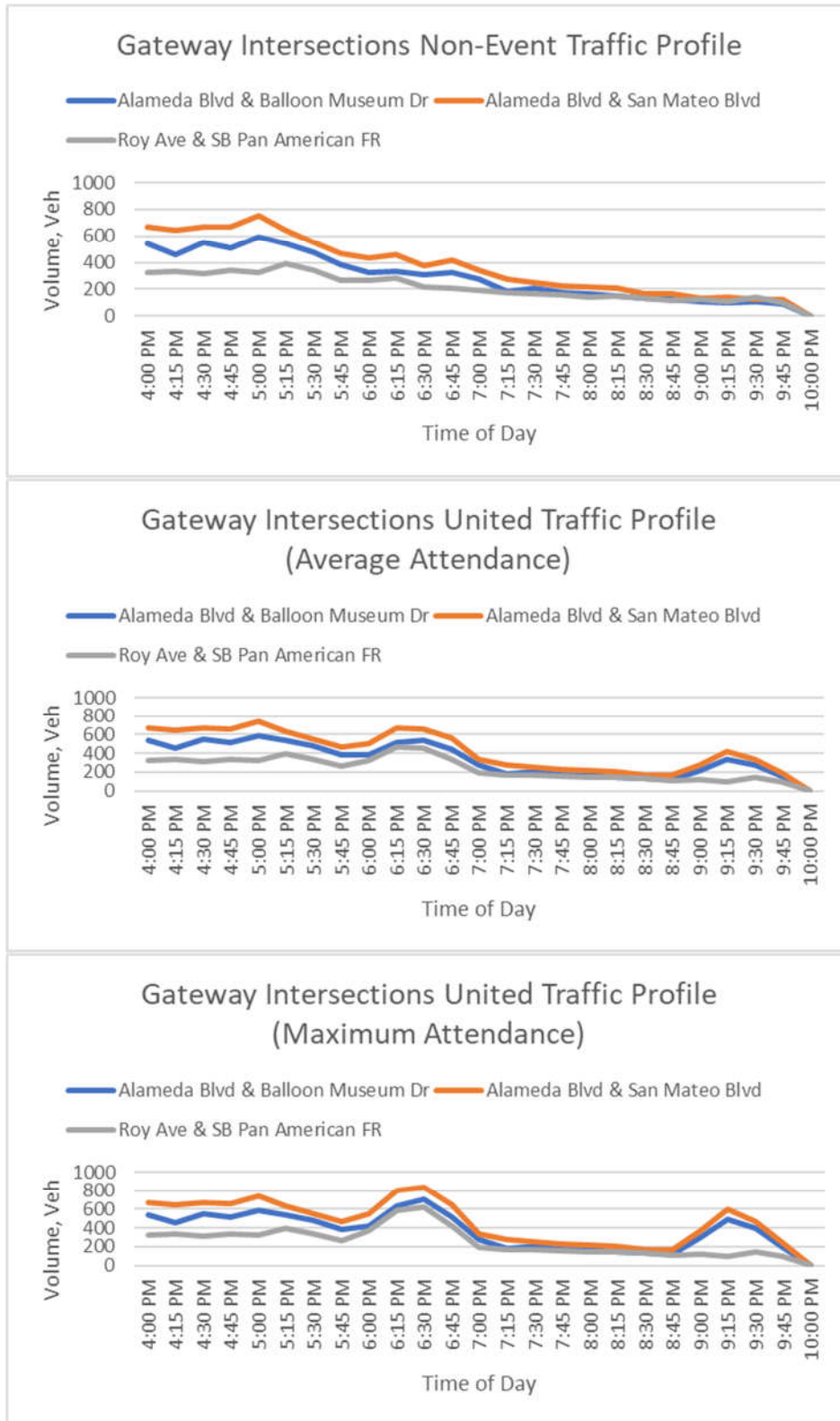

Figure 18: PM Peak Hour and Stadium Event Traffic Volume Profile Comparison

## Traffic Control Concept

To establish an initial traffic control concept, Lee Engineering used the proceeding HCS results to identify lane groups at the study intersections, which cannot effectively accommodate the ingress or egress traffic volumes. Presently, the Alameda Blvd corridor within the study area regularly sees traffic volumes on par with those expected to be generated by the proposed stadium. The first step of any traffic control plan under consideration is limiting access to Jefferson St north of Alameda Blvd. The northern leg of Jefferson St at Alameda Blvd should be closed to through traffic to provide neighborhood access to residents and restrict stadium event traffic from disrupting the area's residential communities. The closing of Jefferson to event traffic is warranted regardless of whether the TCP is for average or maximum anticipated attendance.

### Average Attendance Traffic Control Concept

During the 6 to 7 PM ingress period, none of the entering lane groups at the study intersections showed an LOS worse than D. Given these levels of service, entering regular event traffic would be best served by a light traffic control footprint with police officers placed at the intersection of Balloon Fiesta Pkwy and San Mateo Blvd to provide direction and balance for inbound traffic flows westbound on Balloon Fiesta Pkwy and northbound on San Mateo Blvd turning left onto Balloon Fiesta Pkwy. Officers or traffic control volunteers are also warranted as vehicles approach the designated parking lots to facilitate smooth entry operations and clear drivers from the roadway in an orderly manner. While the roadway capacity can handle the ingress traffic, delays at parking lot entrances that spill back into the roadway could be problematic far upstream.

During ingress operations, entering traffic flows are facilitated because the existing roadway configuration is designed for high volumes along the ingress-associated lane groups. The traffic signals and two-way-stop-controlled intersections either provide sufficient green time or allow the ingress traffic free flow. Potentially, an event traffic signal timing plan may need to be developed.

As traffic exits the stadium, the egress routes result in high volumes moving through lane groups designed to carry lower traffic volumes. This is consistent for the internal stop-control intersections where egress traffic approaches two-way-stop-controlled intersections from the signed stop legs of the intersection. It is also consistent with the gateway intersections of Alameda with San Mateo Blvd and Balloon Museum Dr, where the exiting lane group is not typically assigned a large enough share of signal green time to accommodate the egress queue.

To mitigate the egress delay and queues, the internal intersections included in this study would benefit from active traffic flow management by police officers. The signalized intersections of Alameda Blvd with Balloon Museum Dr and San Mateo Blvd would likely be capable of accommodating egress flow with the implementation of a signal timing plan for the stadium events.

**Table 10: HCS Results for Egress Operations with Normal Signal Timing vs. Event Egress Signal Timing**

Alameda Blvd & Balloon Museum Dr											
Time	Movement	Delay and Level of Service				Time	Movement	Delay and Level of Service			
		95th % (ft)	Delay (s/veh)	LOS	Overall LOS			95th % (ft)	Delay (s/veh)	LOS	Overall LOS
Egress with Regular Signal Timing	EBL	< 1 Veh	0.0	---	F	Egress with Event Signal Timing	EBL	< 1 Veh	0.0	---	D
	EBT	49.0	9.5	A			EBT	74.4	18.2	B	
	EBR	< 1 Veh	0.0	---			EBR	< 1 Veh	0.0	---	
	WBL	< 1 Veh	8.2	A			WBL	< 1 Veh	16.1	B	
	WBT	40.4	8.1	A			WBT	63.6	16.1	B	
	WBR	< 1 Veh	---	---			WBR	< 1 Veh	---	---	
	NBL	< 1 Veh	0.0	---			NBL	< 1 Veh	0.0	---	
	NBT	< 1 Veh	39.1	D			NBT	< 1 Veh	26.1	C	
	NBR	---	---	---			NBR	---	---	---	
	SBL	< 1 Veh	37.0	D			SBL	< 1 Veh	24.4	C	
	SBT	< 1 Veh	0.0	---			SBT	< 1 Veh	0.0	---	
SBR	3595.0	48.3	F	SBR	679.5	49.4	D				
Alameda Blvd and San Mateo Blvd											
Time	Movement	Delay and Level of Service				Time	Movement	Delay and Level of Service			
		95th % (ft)	Delay (s/veh)	LOS	Overall LOS			95th % (ft)	Delay (s/veh)	LOS	Overall LOS
Egress with Regular Signal Timing	EBL	< 1 Veh	6.0	A	F	Egress with Event Signal Timing	EBL	< 1 Veh	26.9	C	D
	EBT	46.0	6.7	A			EBT	119.8	29.4	C	
	EBR	< 1 Veh	---	---			EBR	< 1 Veh	---	---	
	WBL	< 1 Veh	5.9	A			WBL	< 1 Veh	26.8	C	
	WBT	36.0	6.5	A			WBT	94.1	28.8	C	
	WBR	35.6	6.5	A			WBR	93.0	28.9	C	
	NBL	< 1 Veh	43.8	D			NBL	< 1 Veh	14.9	B	
	NBT	< 1 Veh	43.0	D			NBT	< 1 Veh	14.6	B	
	NBR	---	---	---			NBR	---	---	---	
	SBL	7996.1	2373.0	F			SBL	807.5	42.6	D	
	SBT	< 1 Veh	43.3	D			SBT	< 1 Veh	14.7	B	
SBR	---	---	---	SBR	---	---	---				

**Average Expected Attendance Traffic Control Concept Summary**

The following is a summation of the traffic control measures anticipated to be required for the traffic volumes associated with an average attendance United game held in the proposed stadium:

- Close Jefferson St north of Alameda Blvd to event traffic for both ingress and egress.
- Implement an event egress signal timing plan at Alameda Blvd and Balloon Museum as well as at Alameda Blvd and San Mateo Blvd.
- Provide active traffic management via officer traffic control at the intersections of Ballon Fiesta Pkwy and San Mateo Blvd during ingress and egress
- Extend officer traffic management to San Mateo Blvd and San Diego Ave and Balloon Fiesta Pkwy and Southbound Pan American Frontage Rd for egress operations

**Maximum Attendance Traffic Control Concept**

A more extensive and larger traffic control plan would be required for stadium events anticipated to generate maximum attendance. The trips generated by a full-capacity event would exceed the roughly 2,000 vehicle-per-hour capacity through the gateway intersections and result in long queues. These queues created could potentially spill back out of the lane group storage lengths or back up into upstream intersections.

Given the amount by which the gateway intersection capacity is exceeded and the resultant spillback queues, HCS analysis can not accurately provide delay and level of service information. The use of mitigating signal timing plans does not alleviate the queue conditions enough to prevent the need for additional traffic control measures.

For maximum attendance events, the second available eastbound lane of Balloon Fiesta Pkwy should be opened to allow two lanes of traffic to proceed from the parking lots to the Southbound Pan American Frontage Rd and make dual right turns. Officer control will likely be necessary at all study intersections. However, the maximum attendance traffic is not so intense as to necessitate the closure of Alameda Blvd to normal through traffic.

### Maximum Expected Attendance Traffic Control Concept Summary

The following is a summation of the traffic control measures anticipated to be required for the traffic volumes associated with a full-capacity attendance United game held in the proposed stadium:

- Close Jefferson St north of Alameda Blvd to event traffic for both ingress and egress.
- Provide active traffic management via officer traffic control at the intersections of Balloon Fiesta Pkwy and San Mateo Blvd, San Mateo Blvd and San Diego Ave, and Balloon Fiesta Pkwy and Southbound Pan American Frontage Rd for both ingress and egress operations.
- Provide active traffic management via officer traffic control at the intersections of Alameda Blvd with both San Mateo Blvd and Balloon Museum Dr during ingress operations with additional office control at Alameda and Southbound Pan American Frontage Rd during egress.
- Open the second eastbound lane of Balloon Fiesta Pkwy and provide dual right turns from Balloon Fiesta Pkwy onto the frontage road for egress.
- Consider closing the Southbound Pan American Frontage Rd to non-event traffic during egress.

## Conclusion

Overall, the proposed United Stadium is concluded to have a smaller impact compared to Balloon Fiesta event traffic. For the average stadium event with 60% percent of seating capacity filled, anticipated ingress and egress traffic result in traffic volumes when combined with non-event traffic to volumes comparable to the Alameda Blvd corridor operations under regular weekday rush hour traffic. For maximum attendance events, the combination of normal traffic with event traffic results in volumes approximating a single hour's worth of Balloon Fiesta demand. Regular United games would likely require about the same level and intensity as those implemented today for United games held at the Isotopes Park. Maximum attendance games are anticipated to require a level of traffic control closer to that seen during the Balloon Fiesta in scope but less intensive with regard to the implementation of traffic control devices.

RE-NOTIFICATION

**PROPERTY OWNERS WITHIN 100-BUFFER**

<b>OWNER</b>	<b>OWNADD</b>	<b>OWNADD2</b>
SERRANO CLARA V	10017 EDITH BLVD NE	ALBUQUERQUE NM 87113
DE LOS SANTOS CARMELO & KUAJARA MARIA E	4904 WATERCRESS DR NE	ALBUQUERQUE NM 87113
DE LA O PATRICK & KENDRA	10164 EDITH BLVD NE	ALBUQUERQUE NM 87113-2414
3711 PASEO INDUSTRIAL LLC	PO BOX 19080	BOULDER CO 80308-2080
AMAFCA	2600 PROSPECT AVE NE	ALBUQUERQUE NM 87107-1836
ALBUQUERQUE INTERNATIONAL BALLOON FIESTA INC	4401 ALAMEDA NE	ALBUQUERQUE NM 87113-1554
9019 WASHINGTON NE LLC	8500 WASHINGTON ST NE SUITE A-5	ALBUQUERQUE NM 87113-1861
CITY OF ALBUQUERQUE	PO BOX 2248	ALBUQUERQUE NM 87103-2248
8405 WASHINGTON NE LLC	8500 WASHINGTON ST NE	ALBUQUERQUE NM 87113-1846
WILLIAMS LADONNA D TRUSTEE WILLIAMS SEPARATE PROPERTY TRUST	10218 EDITH BLVD NE	ALBUQUERQUE NM 87113-2400
CITY OF ALBUQUERQUE	PO BOX 1293	ALBUQUERQUE NM 87103-2248
PUEBLO OF SANDIA	481 SANDIA LOOP RD	BERNALILLO NM 87004
MCILHANEY MICHAEL A & AARON T MCILHANEY	6980 PACIFIC COAST ST	LAS VEGAS NV 89148-3823
ARCHDIOCESE OF SANTA FE REAL ESTATE CORP/NATIVITY OF THE BLESSED MARY	4000 ST JOSEPHS PL NW	ALBUQUERQUE NM 87120-1714
VSSW HOLDINGS LLC	17019 S WEBER DR	CHANDLER AZ 85226-4114
ROMERO CRESTINO D	10004 EDITH BLVD NE	ALBUQUERQUE NM 87113-2402
RICHFIELD PARK 35 LLC	2321 CANDELARIA RD NW	ALBUQUERQUE NM 87107-3055
NM STATE HIGHWAY & TRANS DEPT C/O RONALD E GALNES	PO BOX 1149	SANTA FE NM 87504-1149
CITY OF ALBUQUERQUE	PO BOX 1293	ALBUQUERQUE NM 87103-2248
SANTILLANES PAUL D	10126 EDITH BLVD NE	ALBUQUERQUE NM 87113-2404
CHAVEZ KENNETH W ETUX	10154 EDITH BLVD NE	ALBUQUERQUE NM 87113
PRESBYTERIAN HEALTHCARE SERVICES REAL ESTATE DEPARTMENT	PO BOX 26666	ALBUQUERQUE NM 87125-6666
VILLEGAS RAMON JR & TINA M	10212 EDITH BLVD NE	ALBUQUERQUE NM 87113
PUEBLO OF SANDIA	481 SANDIA LOOP RD	BERNALILLO NM 87004
GRIEGO ALVIN RICHARD & ANNA MARIE	10166 EDITH BLVD NE	ALBUQUERQUE NM 87113-2414
SOUTHWESTERN LINE CONSTRUCTION ELECTRICAL JOINT APPRENTICESHIP ETAL	8425 WASHINGTON PL NE	ALBUQUERQUE NM 87113-1672
MCM WASHINGTON LLC	1907 BUENA VISTA HWY SE SUITE 100	ALBUQUERQUE NM 87106-4246
MARTIN LYNN TODD CO-TRUSTEE MARTIN RVT	10200 EDITH BLVD NE	ALBUQUERQUE NM 87113
SANPREVEST LLC	9201 SAN MATEO BLVD NE	ALBUQUERQUE NM 87113-2227
BP ALAMEDA LLC	18 TWIN PEAKS RD SE	ALBUQUERQUE NM 87123-3981
DE LA O VELMA	10156 EDITH BLVD NE	ALBUQUERQUE NM 87113-2414
LOOP INDUSTRIAL DEVELOPMENT LLC	4131 BARBARA LP SE SUITE 2 C	RIO RANCHO NM 87124-1362

BECKES JEROME F	8401 WASHINGTON PL NE	ALBUQUERQUE NM 87113-1672
GOPHER BAROQUE LLC	PO BOX 92620	ALBUQUERQUE NM 87199-2620
MECHENBIER MICHAEL & KATHLEEN RVCBL TRUST	4400 ALAMEDA BLVD NE SUITE E	ALBUQUERQUE NM 87113-1519
RH EMMERSON & SON LLC	PO BOX 496014	REDDING CA 96049-6014
PUEBLO OF SANDIA	481 SANDIA LOOP RD	BERNALILLO NM 87004
RDP ENTERPRISES LLC	8724 ALAMEDA PARK DR NE SUITE F	ALBUQUERQUE NM 87113-2454
WERNER ENTERPRISES INC	14507 FRONTIER RD	OMAHA NE 68138
COYNE JAMES P	1724 MENAUL BLVD NW	ALBUQUERQUE NM 87107-1030
PRM WEST LLLP	15836 N 77TH ST	SCOTTSDALE AZ 85260-1700
SUMCO PHOENIX CORPORATION	9401 SAN MATEO BLVD NE	ALBUQUERQUE NM 87114
8920 ADAMS NE LLC	8500 WASHINGTON ST NE SUITE A-5	ALBUQUERQUE NM 87113-1861
PEREA MANUEL R & ROSEMARY	4900 WATERCRESS DR NE	ALBUQUERQUE NM 87113
COMMERCIAL ENTERPRISES INC	8309 WASHINGTON PL NE	ALBUQUERQUE NM 87113-1670
BERNALILLO COUNTY C/O COUNTY MANAGER	415 SILVER AVE SW	ALBUQUERQUE NM 87102-3225
ALBUQUERQUE BERNALILLO COUNTY WATER UTILITY AUTHORITY	PO BOX 1293	ALBUQUERQUE NM 87103-1293
SANDBURG MARC L & DEBORAH K	10136 EDITH BLVD NE	ALBUQUERQUE NM 87113
MONTOYA CHARLES C	5911 4TH ST NW	ALBUQUERQUE NM 87107
BONESTEEL STEVEN W & DEBRA M	10128 EDITH BLVD NE	ALBUQUERQUE NM 87113-2404
LYNN PROPERTIES LLC	10200 EDITH BLVD NE	ALBUQUERQUE NM 87113
8633 PASEO ALAMEDA LLC	313 PERFECTO LOPEZ RD	CORRALES NM 87048-5109
WESTERN GROUP	1395 N HAYDEN RD	SCOTTSDALE AZ 85257-3769
RIVERA BERNIE H & MELBA SALAS	4905 WATERCRESS NE	ALBUQUERQUE NM 87113
SANDBURG DEBBIE	10136 EDITH BLVD NE	ALBUQUERQUE NM 87113-2412
LUCERO ANTHONY R TRUSTEE LUCERO TRUST	10150 EDITH BLVD NE	ALBUQUERQUE NM 87113-2412
TAFOYA LUIS B	10148 EDITH BLVD NE	ALBUQUERQUE NM 87113
8905 WASHINGTON NE LLC	34 RINCON DE CHOLLA	CORRALES NM 87048
SOUTHWESTERN LINE CONST ELECTRICAL JOINT APPRENTICESHIP & TRAINING PROGRAM INC	8425 WASHINGTON PL NE	ALBUQUERQUE NM 87113
W/A LLC	642 SOLAR RD NW	ALBUQUERQUE NM 87107-5744
ARAGON AMANDA JENAE	9628 DEL FUEGO CIR NE	ALBUQUERQUE NM 87113-2316
8820 HORIZON BLVD NM LLC	4525 WILSHIRE BLVD SUITE 210	LOS ANGELES CA 90010-3846
TRACT 3B-2-B LLC	8830 HORIZON BLVD NE	ALBUQUERQUE NM 87113-1689
ARCHDIOCESE OF SANTA FE REAL ESTATE CORP/NATIVITY OF THE BLESSED VIRGIN MARY	4000 ST JOSEPHS PL NW	ALBUQUERQUE NM 87120-1714
COLONIAL OAKS ALBUQUERQUE PROPERTY COMPANY LLC	2315 ROUTH ST	DALLAS TX 75201-2025
VSSW HOLDINGS LLC	17019 S WEBER DR	CHANDLER AZ 85226-4114
FACILITY SOLUTIONS GROUP INC	4401 WESTGATE BLVD SUITE 310	AUSTIN TX 78745-1494

BERNALILLO COUNTY C/O COUNTY MANAGER	415 SILVER AVE SW	ALBUQUERQUE NM 87102-3225
GENERAL MILLS CEREALS PROPERTIES LLC C/O TAX DEPT	PO BOX 1113	MINNEAPOLIS MN 55440-1113
JOHNSON SIDNEY WILBORN & GONZALES LUELENA GABRIELLE	101 ROSEMONT AVE NE	ALBUQUERQUE NM 87102
BECKER FRED ALBERT & KATHLEEN ANN	10430 AMARA VISTA CT NE	ALBUQUERQUE NM 87113-2574
SERRANO SIMON E JR	10434 AMARA VISTA CT NE	ALBUQUERQUE NM 87113-2574
AMARA VISTA HOMEOWNERS ASSOCIATION INC	PO BOX 94088	ALBUQUERQUE NM 87199-4088
SAAVEDRA ERIC J & ELISA A	10438 AMARA VISTA CT NE	ALBUQUERQUE NM 87113-2574
MARTINEZ EDWARD A	5513 ROLLING MEADOWS DR	FORT WORTH TX 76123-2838
AMARA VISTA HOMEOWNERS ASSOCIATION INC	PO BOX 94088	ALBUQUERQUE NM 87199-4088
BACA JAMIE JOSE TRUSTEE BACA RVT	10446 AMARA VISTA CT NE	ALBUQUERQUE NM 87113-2574
SUMCO PHOENIX CORPORATION	9401 SAN MATEO BLVD NE	ALBUQUERQUE NM 87114
PRESBYTERIAN HEALTHCARE SERVICES ATTN: REAL ESTATE DEPARTMENT	PO BOX 26666	ALBUQUERQUE NM 87125
8801 HORIZON PARTNERS LLC	8830 HORIZON BLVD NE	ALBUQUERQUE NM 87113-1588
YOUNG MARY TRAN & SAMUEL MARK	4036 GONDOLA WAY NE	ALBUQUERQUE NM 87113-2484
BAILEY JENNA	4032 GONDOLA WAY NE	ALBUQUERQUE NM 87113-2484
KING JAY SALAZAR & MURLEE SALAZAR	PO BOX 95722	ALBUQUERQUE NM 87199-5722
WILES ANN M TRUSTEE WILES FAMILY TRUST	PO BOX 67575	ALBUQUERQUE NM 87193-7575
GAMMA DEVELOPMENT LLC	9798 COORS BLVD NW SUITE C-400	ALBUQUERQUE NM 87114-6131
JOHNSON JUANITA LOUISE & MEEKS KENNETH EARL	9208 DAWN PATROL TRL NE	ALBUQUERQUE NM 87113-2483
PETERSON KAITLIN	9212 DAWN PATROL TRL NE	ALBUQUERQUE NM 87113-2483
ENCHANTED ESCAPE LLC	7451 PAN AMERICAN FWY	ALBUQUERQUE NM 87109-0000
MOUSLEH NADIA E & BATESON BENJAMIN L	9220 DAWN PATROL TRL NE	ALBUQUERQUE NM 87113-2483
MARTINEZ & SONS LLC	9224 DAWN PATROL TRL NE	ALBUQUERQUE NM 87113-2483
ABRAZO HOMES LLC	PO BOX 65808	ALBUQUERQUE NM 87193-5808
TOMAS ALEXANDER	9236 DAWN PATROL TRL NE	ALBUQUERQUE NM 87113-2483
SPRINGER MICHAEL H	9810 EDITH BLVD NE	ALBUQUERQUE NM 87113-2318
SAIZ MARTIN F	9820 EDITH BLVD NE	ALBUQUERQUE NM 87113-2318
ARAGON AMANDA JENAE	9628 DEL FUEGO CIR NE	ALBUQUERQUE NM 87113-2316



# Property Owners within 100-foot Buffer







# Property Owners within 100-foot Buffer



# Property Owners within 100-foot Buffer





# Property Owners within 100-foot Buffer





# Property Owners within 100-foot Buffer



**SITUS ADDRESS IN BUFFER IF DIFFERENT FROM PROPERTY OWNER**

OWNER		
ARCHULETA CANDELARIA & ARCHULETA RAY & MARGIE	10404 EDITH BLVD NE	ALBUQUERQUE NM 87113
ENCINIAS ERMINIO & ENCINIAS MERCEDES	10400 EDITH BLVD NE	ALBUQUERQUE NM 87113
3711 PASEO INDUSTRIAL LLC	3711 PASEO DEL NORTE NE	ALBUQUERQUE NM 87113
ALBUQUERQUE INTERNATIONAL BALLOON FIESTA INC	8901 WASHINGTON NE	ALBUQUERQUE NM 87113
9019 WASHINGTON NE LLC	9019 WASHINGTON ST NE	ALBUQUERQUE NM 87113
CITY OF ALBUQUERQUE	8612 ALAMEDA PARK DR NW	ALBUQUERQUE NM 87113
CITY OF ALBUQUERQUE	8536 ALAMEDA PARK DR NW	ALBUQUERQUE NM 87113
CITY OF ALBUQUERQUE	8624 ALAMEDA PARK DR NW	ALBUQUERQUE NM 87113
MCILHANEY MICHAEL A & AARON T MCILHANEY	4901 WATERCRESS DR NE	ALBUQUERQUE NM 87113
VSSW HOLDINGS LLC	9005 WASHIGTON ST NE	ALBUQUERQUE NM 87113 2705
RICHFIELD PARK 35 LLC	9009 WASHINGTON NE	ALBUQUERQUE NM 87113
CITY OF ALBUQUERQUE	8524 ALAMEDA PARK DR NW	ALBUQUERQUE NM 87113
ALBUQ INTERNATIONAL BALLOON FIESTA INC	8805 WASHINGTON ST NE	ALBUQUERQUE NM 87113
PRESBYTERIAN HEALTHCARE SERVICES REAL ESTATE DEPARTMENT	SAN MATEO BLVD NW	ALBUQUERQUE NM 87113
SOUTHWESTERN LINE CONSTRUCTION ELECTRIAL JOINT APPRENTICESHIP ETAL	8407 WASHINGTON PL NE	ALBUQUERQUE NM 87113
MCM WASHINGTON LLC	8333 WASHINGTON PL NE	ALBUQUERQUE NM 87113
LOOP INDUSTRIAL DEVELOPMENT LLC	4101 PASEO DEL NORTE NE	ALBUQUERQUE NM 87113
GOPHER BAROQUE LLC	9007 WASHINGTON ST NE	ALBUQUERQUE NM 87113
RH EMMERSON & SON LLC	8601 PRESIDENT PL	ALBUQUERQUE NM 87113
CITY OF ALBUQUERQUE	8512 ALAMEDA PARK DR NW	ALBUQUERQUE NM 87113
WERNER ENTERPRISES INC	3801 PASEO DEL NORTE NE	ALBUQUERQUE NM 87113
HONE JAY R	10162 EDITH BLVD NE	ALBUQUERQUE NM 87113
COYNE JAMES P	10206 EDITH BLVD NE	ALBUQUERQUE NM 87113 2400
PRM WEST LLLP	8301 WASHINGTON PL NE	ALBUQUERQUE NM 87113
SUMCO PHOENIX CORPORATION	5031 SAN DIEGO AVE NE	ALBUQUERQUE NM 87113
8920 ADAMS NE LLC	8920 ADAMS ST NE	ALBUQUERQUE NM 87113
COMMERCIAL ENTERPRISES INC	8309 WASHINGTON PL NE	ALBUQUERQUE NM 87113
CHAVEZ DANIEL R & GALLEGOS LORRIE M	10416 EDITH BLVD NE	ALBUQUERQUE NM 87113
ALBUQUERQUE BERNALILLO COUNTY WATER UTILITY AUTHORITY	9200 JEFFERSON ST NE	ALBUQUERQUE NM 87113
MONTOYA CHARLES C	10124 EDITH BLVD NE	ALBUQUERQUE NM 87113

LYNN PROPERTIES LLC	9914 EDITH BLVD NE	ALBUQUERQUE NM 87113
8633 PASEO ALAMEDA LLC	8809 WASHINGTON ST NE	ALBUQUERQUE NM 87113
WESTERN GROUP	8305 WASHINGTON PL NE	ALBUQUERQUE NM 87113
8905 WASHINGTON NE LLC	8905 WASHINGTON ST NE	ALBUQUERQUE NM 87113
CITY OF ALBUQUERQUE	9011 SAN MATEO BLVD NE	ALBUQUERQUE NM 87113
W/A LLC	3701 PASEO DEL NORTE NE	ALBUQUERQUE NM 87113
CHAVEZ KENNETH W SR & KATHY A	10152 EDITH BLVD NE	ALBUQUERQUE NM 87113
CITY OF ALBUQUERQUE	8600 ALAMEDA PARK DR NW	ALBUQUERQUE NM 87113
ARAGON AMANDA JENAE	10014 EDITH BLVD NE	ALBUQUERQUE NM 87113
8820 HORIZON BLVD NM LLC	8820 HORIZON BLVD NE	ALBUQUERQUE NM 87113
COLONIAL OAKS ALBUQUERQUE PROPERTY COMPANY LLC	8810 HORIZON DR NE 1	ALBUQUERQUE NM 87113
VSSW HOLDINGS LLC	9001 WASHINGTON ST NE	ALBUQUERQUE NM 87113
FACILITY SOLUTIONS GROUP INC	8909 WASHINGTON ST NE	ALBUQUERQUE NM 87113
BERNALILLO COUNTY C/O COUNTY MANAGER	8901 JEFFERSON ST NE	ALBUQUERQUE NM 87113
GENERAL MILLS CEREALS PROPERTIES LLC C/O TAX DEPT	3501 PASEO DEL NORTE NE	ALBUQUERQUE NM 87113
JOHNSON SIDNEY WILBORN & GONZALES LUELENA GABRIELLE	10426 AMARA VISTA CT NW	ALBUQUERQUE NM 87113
MARTINEZ LEONARD	10437 AMARA VISTA CT NW	ALBUQUERQUE NM 87113
TITAN INVESTMENTS LLC	10441 AMARA VISTA CT NW	ALBUQUERQUE NM 87113
AMARA VISTA HOMEOWNERS ASSOCIATION INC	10451 AMARA VISTA CT NW	ALBUQUERQUE NM 87113
MARTINEZ EDWARD A	10442 AMARA VISTA CT NW	ALBUQUERQUE NM 87113
PRESBYTERIAN HEALTHCARE SERVICES ATTN: REAL ESTATE DEPARTMENT	9521 SAN MATEO BLVD NE	ALBUQUERQUE NM 87113
KING JAY SALAZAR & MURLEE SALAZAR	9200 DAWN PATROL TRL NE	ALBUQUERQUE NM 87113
WILES ANN M TRUSTEE WILES FAMILY TRUST	9204 DAWN PATROL TRL NE	ALBUQUERQUE NM 87113
ENCHANTED ESCAPE LLC	9216 DAWN PATROL TRL NE	ALBUQUERQUE NM 87113
GAMMA DEVELOPMENT LLC	9228 DAWN PATROL TRL NE	ALBUQUERQUE NM 87113
ABRAZO HOMES LLC	9232 DAWN PATROL TRL NE	ALBUQUERQUE NM 87113
AROMAZ INVESTMENTS LLC	10316 EDITH BLVD NE	ALBUQUERQUE NM 87113

# SITUS Buffer Addresses if Different from Property Owner

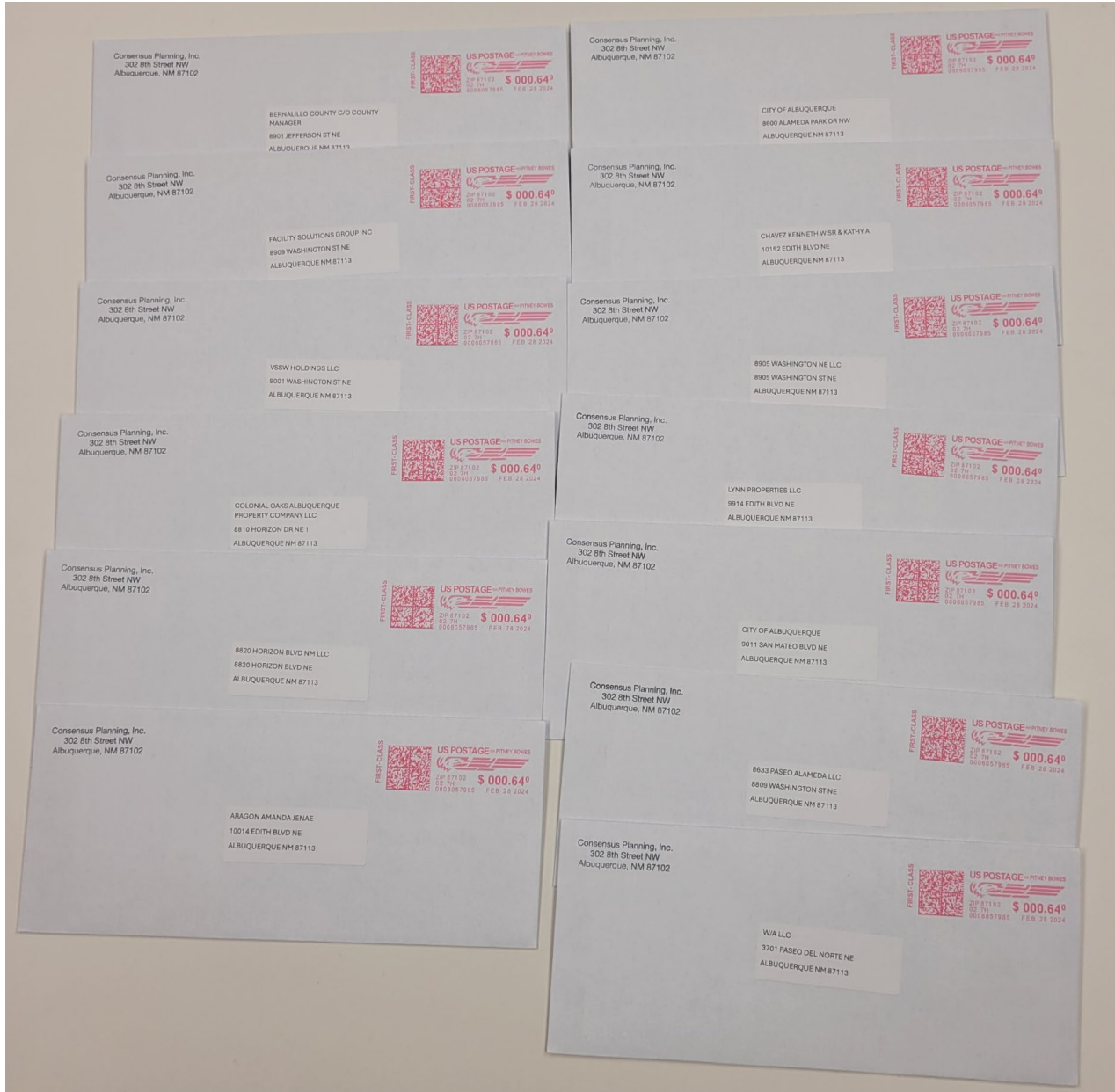

# SITUS Buffer Addresses if Different from Property Owner





# SITUS Buffer Addresses if Different from Property Owner



**ADDITIONAL CONTACTS NOT IN BUFFER**

<b>OWNER</b>	<b>OWNADD</b>	<b>OWNADD2</b>
CLEARBROOK INVESTMENTS INC	8801 JEFFERSON ST NE BLDG A	ALBUQUERQUE NM 87113-2438
8814 HORIZON LLC	8814 HORIZON BLVD NE	ALBUQUERQUE NM 87113-1588
8820 HORIZON BLVD NM LLC	4525 WILSHIRE BLVD SUITE 210	LOS ANGELES CA 90010-3846
TRACT 3B-2-B LLC	8830 HORIZON BLVD NE	ALBUQUERQUE NM 87113-1689
COLONIAL OAKS ALBUQUERQUE PROPERTY COMPANY LLC	2315 ROUTH ST	DALLAS TX 75201-2025
CITY OF ALBUQUERQUE	PO BOX 1293	ALBUQUERQUE NM 87103-2248
8801 HORIZON PARTNERS LLC	8830 HORIZON BLVD NE	ALBUQUERQUE NM 87113-1588
GAMMA DEVELOPMENT LLC	9798 COORS BLVD NW SUITE C-400	ALBUQUERQUE NM 87114-6131
YOUNG MARY TRAN & SAMUEL MARK	4036 GONDOLA WAY NE	ALBUQUERQUE NM 87113-2484
BAILEY JENNA	4032 GONDOLA WAY NE	ALBUQUERQUE NM 87113-2484
JUHADI JENNIFER	4028 GONDOLA WAY NE	ALBUQUERQUE NM 87113-2484
MARTINEZ PRESCILLANO & DANNETTE	4024 GONDOLA WAY NE	ALBUQUERQUE NM 87113-2484
FOLK KEVIN RHEA & ANDREA NEMMERS	4020 GONDOLA WAY NE	ALBUQUERQUE NM 87113-2484
LEWIS FRED ALEXANDER	4016 GONDOLA WAY NE	ALBUQUERQUE NM 87113-2484
JETT RICHARD ADAME	4012 GONDOLA WAY NE	ALBUQUERQUE NM 87113-2484
MCMILLAN VANCE & SHANE	4008 GONDOLA WAY NE	ALBUQUERQUE NM 87113-2484
THORN KAREN LEE	4004 GONDOLA WAY NE	ALBUQUERQUE NM 87113-2484
KING JAY SALAZAR & MURLEE SALAZAR	PO BOX 95722	ALBUQUERQUE NM 87199-5722
BRADY RENE & PAMELA DAWN	9201 BALLOON GLOW LN NE	ALBUQUERQUE NM 87113-2493
ESPINOZA MICHAEL A	4025 GONDOLA WAY NE	ALBUQUERQUE NM 87113-2484
HEARTT SARAH LINCOLN TRUSTEE HEARTT RVT FBO SARAH LINCOLN HEARTT	4021 GONDOLA WAY NE	ALBUQUERQUE NM 87113-2484
BAIR RAYMOND E & CAROL A	4017 GONDOLA WAY NE	ALBUQUERQUE NM 87113-2484
CHAVEZ MARK	9200 BALLOON GLOW LN NE	ALBUQUERQUE NM 87113-2493
WILES ANN M TRUSTEE WILES FAMILY TRUST	PO BOX 67575	ALBUQUERQUE NM 87193-7575
ABRAZO HOMES LLC	PO BOX 65808	ALBUQUERQUE NM 87193-5808
LIBERSKY JASON	9209 DAWN PATROL TRL NE	ALBUQUERQUE NM 87113-2483
DELGADO MICHAEL ANTHONY JOSEPH & NICOLE LYNETTE	9204 BALLOON GLOW LN NE	ALBUQUERQUE NM 87113-2493
WILLIAMS BRYAN L & WILLIAMS MARY L TRUSTEES WILLIAMS TRUST	9209 BALLOON GLOW LN NE	ALBUQUERQUE NM 87113-2493
JOHNSON JUANITA LOUISE & MEEKS KENNETH EARL	9208 DAWN PATROL TRL NE	ALBUQUERQUE NM 87113-2483
SMITH JOHN & FOREMAN CHRISTY	9208 BALLOON GLOW LN NE	ALBUQUERQUE NM 87113-2493
DIMEO DAVID R & ZITA R	9213 BALLON GLOW LN NE	ALBUQUERQUE NM 87113-2493
PETERSON KAITLIN	9212 DAWN PATROL TRL NE	ALBUQUERQUE NM 87113-2483
ABAD-MOTA SORAYA & PALACIOS JOSE L	9212 BALLOON GLOW LN NE	ALBUQUERQUE NM 87113-2493
ENCHANTED ESCAPE LLC	7451 PAN AMERICAN FWY	ALBUQUERQUE NM 87109-0000
CHARTRAND MICHAEL C & LEICHT CHRISTOPHER	9217 BALLOON GLOW LN NE	ALBUQUERQUE NM 87113-2493
MOUSLEH NADIA E & BATESON BENJAMIN L	9220 DAWN PATROL TRL NE	ALBUQUERQUE NM 87113-2483
MARTINEZ & SONS LLC	9224 DAWN PATROL TRL NE	ALBUQUERQUE NM 87113-2483

TOMAS ALEXANDER	9236 DAWN PATROL TRL NE	ALBUQUERQUE NM 87113-2483
STILLBROOKE HOMES INC	8801 JEFFERSON ST NE BLDG A	ALBUQUERQUE NM 87113-2438
STILLBROOKE HOMES INC	8801 JEFFERSON NE BLDG A	ALBUQUERQUE NM 87113-2438
CLEARBROOK INVESTMENTS INC	8801 JEFFERSON ST NE BLDG A	ALBUQUERQUE NM 87113-2438
STILLBROOKE HOMES INC	8801 JEFFERSON ST NE BLDG A	ALBUQUERQUE NM 87113-2438
STILLBROOKE HOMES INC	8801 JEFFERSON ST NE NO. 100	ALBUQUERQUE NM 87113-2438

# Additional Contacts not in Buffer





# Additional Contacts not in Buffer





**ADDITIONAL ADDRESS ON EDITH**

<b>Owner</b>	<b>ADDRESS</b>	<b>ADDRESS 2</b>
JTR LLC		ALBUQUERQUE NM 87154-1941
PACHECO HENRY JR & DEBORAH A CO-TRUSTEES PACHECO RVT	N/A	ALBUQUERQUE NM 87114
PEREA JUSTIN D & DARLENE B	10105 EDITH BLVD NE	ALBUQUERQUE NM 87113
DURAN LILLIAN G	10107 EDITH BLVD NE	ALBUQUERQUE NM 87113-2403
WEINBERGR KIMBERLY M & KVARNSTROM CARL L & ROSE A	10109 EDITH BLVD NE	ALBUQUERQUE NM 87113-2403
ATENCIO MICHELLE & LEONARD C DURAN	10111 EDITH BLVD NE	ALBUQUERQUE NM 87113
ROMERO SYLVIA KATHY	10168 EDITH BLVD NE	ALBUQUERQUE NM 87113-2319
CITY OF ALBUQUERQUE	10218 EDITH NW	ALBUQUERQUE NM 87103-2248
BLOWERS BRUCE D	10330 EDITH BLVD NE	ALBUQUERQUE NM 87190-3043
RIGHT ON LLC	10404 EDITH BLVD NE	ALBUQUERQUE NM 87187
ARCHULETA CANDELARIA & ARCHULETA RAY & MARGIE	3400 VISTA ALAMEDA NW	ALBUQUERQUE NM 87113
ZAMORA MICHAEL J	8501 PASEO ALAMEDA NW	ALBUQUERQUE NM 87112-1261
8633 PASEO ALAMEDA LLC	8505 PASEO ALAMEDA NW	RIO RANCHO NM 87144-7707
TINNIN ROBERT P JR & TINNIN NANCY & TINMIL LLC ATTN: ROBERT P TINNIN JR	8509 PASEO ALAMEDA NE	ALBUQUERQUE NM 87107-6833
ALBUQUERQUE INTERNATIONAL BALLOON FIESTA INC	8515 PASEO ALAMEDA NW	ALBUQUERQUE NM 87113-1554
HSR LLC	8531 PASEO ALAMEDA NE	ALBUQUERQUE NM 87109-2304
HSR LLC	8601 PASEO ALAMEDA NW	ALBUQUERQUE NM 87109-2304
ALAMEDA PARK PROPERTY LLC	8609 PASEO ALAMEDA NW	PLANO TX 75024-6803
RLK-ALAMEDA LLC	8617 PASEO ALAMEDA NE	SANTA FE NM 87501-0331
ZUNA ENTERPRISES LLC C/O ROBERT & STEPHANIE SISSON	8625 PASEO ALAMEDA NW	ALBUQUERQUE NM 87113-1549
DBB REAL ESTATE LLC	8633 PASEO ALAMEDA NE	ALBUQUERQUE NM 87113-1549
GONZALES ARTHUR J & JANIE F	8725 ALAMEDA PARK DR NW	ALBUQUERQUE NM 87114-1816
WILLIAMS LADONNA D TRUSTEE WILLIAMS SEPARATE PROPERTY TRUST	9921 EDITH RD NW	ALBUQUERQUE NM 87113-2400

# Addresses on the East Side of Edith not in Buffer



**PROPERTY OWNER IDENTIFIED BY APPELLANT**

<b>OWNER</b>	<b>OWNADD</b>	<b>OWNADD2</b>
ARCHULETA CANDELARIA & ARCHULETA RAY & MARGIE	10409 EDITH BLVD NE	ALBUQUERQUE NM 87113
ENCINIAS ERMINIO & ENCINIAS MERCEDES	10402 EDITH BLVD NE	ALBUQUERQUE NM 87113
PEREA JUSTIN D & DARLENE B	10168 EDITH BLVD NE	ALBUQUERQUE NM 87113
LINTHICUM LESLIE & HAEDERLE M	10312 EDITH BLVD NE	ALBUQUERQUE NM 87113
GURULE ROBERT	10437 EDITH BLVD NE	ALBUQUERQUE NM 87113-2407
CHAVEZ KENNETH W ETUX	10154 EDITH BLVD NE	ALBUQUERQUE NM 87113
TAFOYA MAX G ETUX	10146 EDITH BLVD NE	ALBUQUERQUE NM 87114
VILLEGAS RAMON JR & TINA M	10212 EDITH BLVD NE	ALBUQUERQUE NM 87113
GRIEGO ALVIN RICHARD & ANNA MARIE	10166 EDITH BLVD NE	ALBUQUERQUE NM 87113-2414
GURULE ROBERT	10437 EDITH BLVD NE	ALBUQUERQUE NM 87113-2407
MARTIN LYNN TODD CO-TRUSTEE MARTIN RVT	10200 EDITH BLVD NE	ALBUQUERQUE NM 87113
GALLEGOS MAX	10414 EDITH BLVD NE	ALBUQUERQUE NM 87113-2408
DE LA O VELMA	10156 EDITH BLVD NE	ALBUQUERQUE NM 87113-2414
CHAVEZ NOE T & EDWINA J	10158 EDITH BLVD NE	ALBUQUERQUE NM 87113-2414
ARCHULETA RAY ANTHONY	10408 EDITH BLVD NE	ALBUQUERQUE NM 87113
HONE JAY R	9220 GUADALUPE TRL NW	ALBUQUERQUE NM 87114-1718
CHAVEZ DANIEL R & GALLEGOS LORRIE M	312 PLAZA MUCHOMAS	BERNALILLO NM 87004-6628
SAIZ MARTIN F	9820 EDITH BLVD NE	ALBUQUERQUE NM 87113-2318
BONESTEEL STEVEN W & DEBRA M	10128 EDITH BLVD NE	ALBUQUERQUE NM 87113-2404
LYNN PROPERTIES LLC	10200 EDITH BLVD NE	ALBUQUERQUE NM 87113
ENCINIAS ERMINIO	10402 EDITH BLVD NE	ALBUQUERQUE NM 87113
SANDBURG DEBBIE	10136 EDITH BLVD NE	ALBUQUERQUE NM 87113-2412
LUCERO ANTHONY R TRUSTEE LUCERO TRUST	10150 EDITH BLVD NE	ALBUQUERQUE NM 87113-2412
TAFOYA LUIS B	10148 EDITH BLVD NE	ALBUQUERQUE NM 87113
ARCHULETA RAY ANTHONY	10408 EDITH BLVD NE	ALBUQUERQUE NM 87113-2408
CHAVEZ KENNETH W SR & KATHY A	10154 EDITH BLVD NE	ALBUQUERQUE NM 87113-2414
SAIZ MARTIN F	9820 EDITH BLVD NE	ALBUQUERQUE NM 87113-2318
MARTINEZ LEONARD	403 C DE BACA LN NW	ALBUQUERQUE NM 87114-1600
TITAN INVESTMENTS LLC	PO BOX 94088	ALBUQUERQUE NM 87199-4088
SERRANO SIMON E JR	10434 AMARA VISTA CT NE	ALBUQUERQUE NM 87113-2574
AMARA VISTA HOMEOWNERS ASSOCIATION INC	PO BOX 94088	ALBUQUERQUE NM 87199-4088
SAAVEDRA ERIC J & ELISA A	10438 AMARA VISTA CT NE	ALBUQUERQUE NM 87113-2574
MARTINEZ EDWARD A	5513 ROLLING MEADOWS DR	FORT WORTH TX 76123-2838
BACA JAMIE JOSE TRUSTEE BACA RVT	10446 AMARA VISTA CT NE	ALBUQUERQUE NM 87113-2574
AROMAZ INVESTMENTS LLC	PO BOX 27688	ALBUQUERQUE NM 87125-7688



# Addresses Identified by Appellants



# Addresses Identified by Appellants

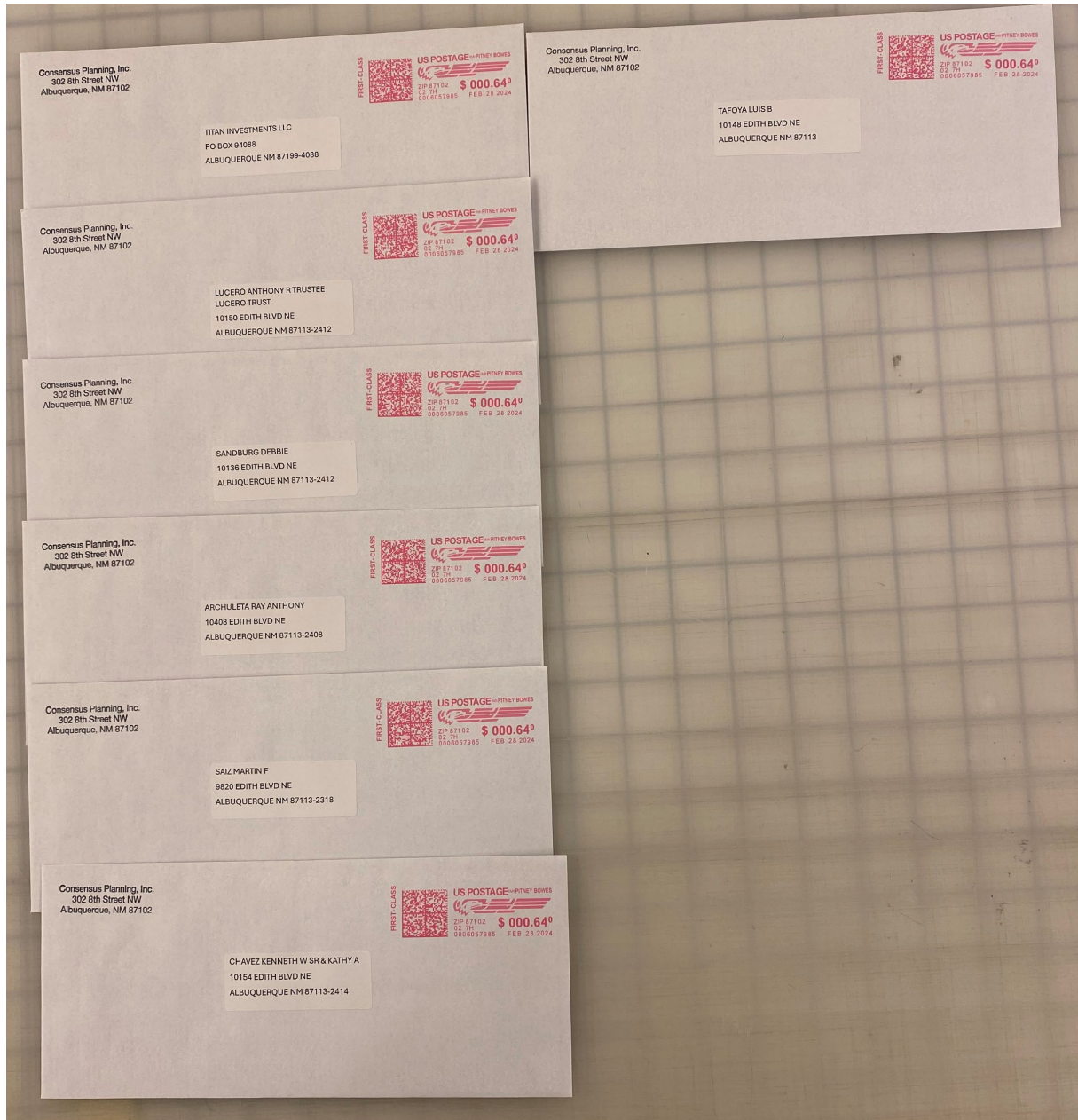



## Meeting Notification - Balloon Fiesta Park / NM United Stadium

Jackie Fishman <fishman@consensusplanning.com>

Wed 2/28/2024 7:22 PM

To: mgriffie@noreste.org <mgriffie@noreste.org>; sec.dist4@gmail.com <sec.dist4@gmail.com>; edueweke@juno.com <edueweke@juno.com>; kbbh@hotmail.com <kbbh@hotmail.com>; ggarcia103@comcast.net <ggarcia103@comcast.net>; Maggie Rose <gypsy.rose46@gmail.com>; hdhauser@comcast.net <hdhauser@comcast.net>; anvanews@aol.com <anvanews@aol.com>; Michael Haederle <haederle@yahoo.com>  
Cc: Charlene Johnson <Johnson@consensusplanning.com>; 'brookemjordy@gmail.com' <brookemjordy@gmail.com>; 'staylor@taylortowers.com' <staylor@taylortowers.com>; alamedamontoya@gmail.com <alamedamontoya@gmail.com>; christinebnvdz@aol.com <christinebnvdz@aol.com>; Tina Villegas <t-marie-v@hotmail.com>; emyers\_11@yahoo.com <emyers\_11@yahoo.com>; 'stemax1@aol.com' <stemax1@aol.com>; grumpyeh46@comcast.net <grumpyeh46@comcast.net>; BARI Harvey <boyznbari@msn.com>; Sandy Z (szus Schlag58@gmail.com) <szus Schlag58@gmail.com>; Bolivar, Silvia A. <sabolivar@cabq.gov>

 1 attachments (7 MB)

RENOTIFICATON NHA\_Emailed-Mailed-Notice-Packet (003).pdf;

Dear Neighbors:

The purpose of this email is to provide notification that the Balloon Fiesta Park Development Plan/Site Plan for Subdivision and Site Plan-EPC for a United New Mexico Soccer Stadium was remanded to the Environmental Planning Commission (EPC) by the Land Use Hearing Officer (LUHO) following an appeal by adjacent neighborhood associations. As part of the remand, the City of Albuquerque is inviting neighborhood associations and neighbors to a facilitated meeting to discuss the request.

The facilitated meeting will be held on **Monday, March 4, 2024, from 5:30 to 7:30 pm**. Representatives from the City of Albuquerque and New Mexico United will be in attendance to answer any questions and listen to community input. The meeting will be facilitated by a City contractor and held online via Google Meet using the link below.

[meet.google.com/xec-uycp-xea](https://meet.google.com/xec-uycp-xea)  
Join by phone +1 414-909-3864, PIN 106965974

The EPC hearing will be held on **Thursday March 21, 2024, starting at 8:40 am**. The public is invited to attend the hearing and provide input regarding this project, which will be held via Zoom using the link below:

<https://cabq.zoom.us/j/2269592859> or by calling the following number: 1 301 715 8592 and entering Meeting ID: 226 959 2859

If you have any questions or concerns, please do not hesitate to contact myself at [fishman@consensusplanning.com](mailto:fishman@consensusplanning.com) or you may also contact the City of Albuquerque Planning Department at [devhelp@cabq.gov](mailto:devhelp@cabq.gov).

Sincerely,

**Jacqueline Fishman, AICP**  
Principal  
Consensus Planning, Inc.  
302 Eighth Street NW  
Albuquerque, NM 87102  
P: 505.764.9801

**From:** [Microsoft Outlook](#)  
**To:** [mgriffee@noreste.org](mailto:mgriffee@noreste.org)  
**Subject:** Relayed: Meeting Notification - Balloon Fiesta Park / NM United Stadium  
**Date:** Wednesday, February 28, 2024 7:22:28 PM  
**Attachments:** [Meeting Notification - Balloon Fiesta Park NM United Stadium.msg](#)

---

Delivery to these recipients or groups is complete, but no delivery notification was sent by the destination server:  
[mgriffee@noreste.org](mailto:mgriffee@noreste.org) ([mgriffee@noreste.org](mailto:mgriffee@noreste.org)) <<mailto:mgriffee@noreste.org>>  
Subject: Meeting Notification - Balloon Fiesta Park / NM United Stadium

**From:** [Microsoft Outlook](#)  
**To:** [edueweke@juno.com](mailto:edueweke@juno.com)  
**Subject:** Relayed: Meeting Notification - Balloon Fiesta Park / NM United Stadium  
**Date:** Wednesday, February 28, 2024 7:25:10 PM  
**Attachments:** [Meeting Notification - Balloon Fiesta Park NM United Stadium.msg](#)

---

Delivery to these recipients or groups is complete, but no delivery notification was sent by the destination server:  
[edueweke@juno.com](mailto:edueweke@juno.com) ([edueweke@juno.com](mailto:edueweke@juno.com)) <<mailto:edueweke@juno.com>>  
Subject: Meeting Notification - Balloon Fiesta Park / NM United Stadium

**From:** [Mail Delivery System](#)  
**To:** [staylor@taylortowers.com](mailto:staylor@taylortowers.com)  
**Subject:** Relayed: Meeting Notification - Balloon Fiesta Park / NM United Stadium  
**Date:** Wednesday, February 28, 2024 7:22:27 PM  
**Attachments:** [Message Headers.msg](#)

---

Delivery to these recipients or groups is complete, but no delivery notification was sent by the destination server:  
[staylor@taylortowers.com](mailto:staylor@taylortowers.com) <<mailto:staylor@taylortowers.com>>  
Subject: Meeting Notification - Balloon Fiesta Park / NM United Stadium

**From:** [Microsoft Outlook](#)  
**To:** [Maggie Rose](#); ["brookemjordy@gmail.com"](mailto:brookemjordy@gmail.com); [alamedamontoya@gmail.com](mailto:alamedamontoya@gmail.com); [Sandy Z \(szuschlag58@gmail.com\)](mailto:Sandy Z (szuschlag58@gmail.com))  
**Subject:** Relayed: Meeting Notification - Balloon Fiesta Park / NM United Stadium  
**Date:** Wednesday, February 28, 2024 7:22:18 PM  
**Attachments:** [Meeting Notification - Balloon Fiesta Park NM United Stadium.msg](#)

---

Delivery to these recipients or groups is complete, but no delivery notification was sent by the destination server:  
[Maggie Rose \(gypsy.rose46@gmail.com\)](mailto:Maggie Rose (gypsy.rose46@gmail.com)) <<mailto:gypsy.rose46@gmail.com>>  
['brookemjordy@gmail.com' \(brookemjordy@gmail.com\)](mailto:'brookemjordy@gmail.com' (brookemjordy@gmail.com)) <<mailto:brookemjordy@gmail.com>>  
[alamedamontoya@gmail.com](mailto:alamedamontoya@gmail.com) ([alamedamontoya@gmail.com](mailto:alamedamontoya@gmail.com)) <<mailto:alamedamontoya@gmail.com>>  
[Sandy Z \(szuschlag58@gmail.com\)](mailto:Sandy Z (szuschlag58@gmail.com)) ([szuschlag58@gmail.com](mailto:szuschlag58@gmail.com)) <<mailto:szuschlag58@gmail.com>>  
Subject: Meeting Notification - Balloon Fiesta Park / NM United Stadium

**From:** [Microsoft Outlook](#)  
**To:** [Michael Haederle; emyers\\_11@yahoo.com](mailto:Michael Haederle; emyers_11@yahoo.com)  
**Subject:** Relayed: Meeting Notification - Balloon Fiesta Park / NM United Stadium  
**Date:** Wednesday, February 28, 2024 7:22:16 PM  
**Attachments:** [Meeting Notification - Balloon Fiesta Park NM United Stadium.msg](#)

---

Delivery to these recipients or groups is complete, but no delivery notification was sent by the destination server:  
[Michael Haederle \(haederle@yahoo.com\)](mailto:Michael Haederle (haederle@yahoo.com)) <<mailto:haederle@yahoo.com>>  
[emyers\\_11@yahoo.com](mailto:emyers_11@yahoo.com) ([emyers\\_11@yahoo.com](mailto:emyers_11@yahoo.com)) <[mailto:emyers\\_11@yahoo.com](mailto:emyers_11@yahoo.com)>  
Subject: Meeting Notification - Balloon Fiesta Park / NM United Stadium

**From:** [Microsoft Outlook](#)  
**To:** [anvanews@aol.com](mailto:anvanews@aol.com); [christinebnvdz@aol.com](mailto:christinebnvdz@aol.com); ["stemax1@aol.com"](mailto:'stemax1@aol.com')  
**Subject:** Relayed: Meeting Notification - Balloon Fiesta Park / NM United Stadium  
**Date:** Wednesday, February 28, 2024 7:22:15 PM  
**Attachments:** [Meeting Notification - Balloon Fiesta Park NM United Stadium.msg](#)

---

Delivery to these recipients or groups is complete, but no delivery notification was sent by the destination server:  
[anvanews@aol.com](mailto:anvanews@aol.com) ([anvanews@aol.com](mailto:anvanews@aol.com)) <<mailto:anvanews@aol.com>>  
[christinebnvdz@aol.com](mailto:christinebnvdz@aol.com) ([christinebnvdz@aol.com](mailto:christinebnvdz@aol.com)) <<mailto:christinebnvdz@aol.com>>  
['stemax1@aol.com' \(stemax1@aol.com\)](mailto:'stemax1@aol.com' (stemax1@aol.com)) <<mailto:stemax1@aol.com>>  
Subject: Meeting Notification - Balloon Fiesta Park / NM United Stadium

**From:** [Microsoft Outlook](#)  
**To:** [ggarcia103@comcast.net](mailto:ggarcia103@comcast.net); [hdhauser@comcast.net](mailto:hdhauser@comcast.net); [grumpyeh46@comcast.net](mailto:grumpyeh46@comcast.net)  
**Subject:** Relayed: Meeting Notification - Balloon Fiesta Park / NM United Stadium  
**Date:** Wednesday, February 28, 2024 7:22:10 PM  
**Attachments:** [Meeting Notification - Balloon Fiesta Park NM United Stadium.msg](#)

---

Delivery to these recipients or groups is complete, but no delivery notification was sent by the destination server:  
[ggarcia103@comcast.net](mailto:ggarcia103@comcast.net) ([ggarcia103@comcast.net](mailto:ggarcia103@comcast.net)) <<mailto:ggarcia103@comcast.net>>  
[hdhauser@comcast.net](mailto:hdhauser@comcast.net) ([hdhauser@comcast.net](mailto:hdhauser@comcast.net)) <<mailto:hdhauser@comcast.net>>  
[grumpyeh46@comcast.net](mailto:grumpyeh46@comcast.net) ([grumpyeh46@comcast.net](mailto:grumpyeh46@comcast.net)) <<mailto:grumpyeh46@comcast.net>>  
Subject: Meeting Notification - Balloon Fiesta Park / NM United Stadium

## 5601 Balloon Fiesta Parkway\_Neighborhood Meeting Inquiry Sheet Submission

Office of Neighborhood Coordination <onc@cabq.gov>

Fri 2/16/2024 1:26 PM

To:Charlene Johnson <Johnson@consensusplanning.com>

1 attachments (1 MB)

IDOZoneAtlasPage\_Balloon Fiesta Park Combined.pdf;

### PLEASE NOTE:

The neighborhood association contact information listed below is valid for 30 calendar days after today's date.

Dear Applicant:

Please find the neighborhood contact information listed below. Please make certain to read the information further down in this e-mail as it will help answer other questions you may have.

Association Name	First Name	Last Name	Email	Alternative Email	Address Line 1	City	State	Zip	Mobile Phone
District 4 Coalition of Neighborhood Associations	Mildred	Griffiee	mgriffiee@noreste.org	sec.dist4@gmail.com	PO Box 90986	Albuquerque	NM	87199	5052
District 4 Coalition of Neighborhood Associations	Ellen	Dueweke	edueweke@juno.com		PO Box 90986	Albuquerque	NM	87199	
Wildflower Area NA	Rebecca	Hall	kbbh@hotmail.com		8908 Bluegrass Court NE	Albuquerque	NM	87113	5052
Wildflower Area NA	Glenn	Garcia	ggarcia103@comcast.net		4901 Goldenthread NE	Albuquerque	NM	87113	

The ONC does not have any jurisdiction over any other aspect of your application beyond this neighborhood contact information. We can't answer questions about sign postings, pre-construction meetings, permit status, site plans, buffers, or project plans, so we encourage you to contact the Planning Department at: 505-924-3857 Option #1, e-mail: [devhelp@cabq.gov](mailto:devhelp@cabq.gov), or visit: <https://www.cabq.gov/planning/online-planning-permitting-applications> with those types of questions.

Please note the following:

- You will need to e-mail each of the listed contacts and let them know that you are applying for an approval from the Planning Department for your project.
- Please use this online link to find the required forms you will need to submit your permit application. <https://www.cabq.gov/planning/urban-design-development/public-notice>.
- The Checklist form you need for notifying neighborhood associations can be found here: [https://documents.cabq.gov/planning/online-forms/PublicNotice/CABQ-Official\\_public\\_notice\\_form-2019.pdf](https://documents.cabq.gov/planning/online-forms/PublicNotice/CABQ-Official_public_notice_form-2019.pdf).
- The Administrative Decision form you need for notifying neighborhood associations can be found here: <https://documents.cabq.gov/planning/online-forms/PublicNotice/Emailed-Notice-Administrative-Print&Fill.pdf>
- Once you have e-mailed the listed contacts in each neighborhood, you will need to attach a copy of those e-mails AND a copy of this e-mail from the ONC to your application and submit it to the Planning Department for approval.

If your application requires you to offer a neighborhood meeting, you can click on this link to find required forms to use in your e-mail to the neighborhood association(s):

<http://www.cabq.gov/planning/urban-design-development/neighborhood-meeting-requirement-in-the-integrated-development-ordinance>

If your application requires a pre-application or pre-construction meeting, please plan on utilizing virtual platforms to the greatest extent possible and adhere to all current Public Health Orders and recommendations. The health and safety of the community is paramount.

If you have questions about what type of notification is required for your particular project or meetings that might be required, please click on the link below to see a table of different types of projects and what notification is required for each:

<https://ido.abc-zone.com/integrated-development-ordinance-ido?document=1&outline-name=6-1%20Procedures%20Summary%20Table>

Thank you,

Suzie



Suzie Flores

Senior Administrative Assistant

Office of Neighborhood Coordination (ONC) | City Council Department | City of Albuquerque

(505) 768-3334 Office

E-mail: [suzannaflores@cabq.gov](mailto:suzannaflores@cabq.gov)

Website: [www.cabq.gov/neighborhoods](http://www.cabq.gov/neighborhoods)

From: webmaster@cabq.gov <webmaster@cabq.gov>  
Sent: Friday, February 16, 2024 11:41 AM  
To: Office of Neighborhood Coordination <johnson@consensusplanning.com>  
Cc: Office of Neighborhood Coordination <onc@cabq.gov>  
Subject: Neighborhood Meeting Inquiry Sheet Submission

[EXTERNAL] Forward to [phishing@cabq.gov](mailto:phishing@cabq.gov) and delete if an email causes any concern.

Neighborhood Meeting Inquiry For:

Environmental Planning Commission

If you selected "Other" in the question above, please describe what you are seeking a Neighborhood Meeting Inquiry for below:

Contact Name

Charlene Johnson

Telephone Number

5057649801

Email Address

[johnson@consensusplanning.com](mailto:johnson@consensusplanning.com)

Company Name

Consensus Planning, Inc.

Company Address

302 8th St. NW

City

Albuquerque

State

NM

ZIP

87102

Legal description of the subject site for this project:

FRACTION LT 2 LOCATED IN NE 1/4 NE 1/4 SEC 11 T11N R3E AKA TR F HEIRS OF FILIBERTO GURULE TR CONT 4.56 AC MORE OR LESS

FRACTION LT 2 LOCATED IN NE 1/4 NE 1/4 SEC 11 T11N R3E AKA TR G HEIRS OF FILIBERTO GURULE TR CONT 4.55 AC MORE OR LESS

Tract A-1 - TR A-1 PLAT OF TRS A-1, B-1, C-1, D-1, E-1, F-1, G-1-A, H-1, I-1-A & I-2-A

Tract B-1 - TR B-1 PLAT OF TRS A-1, B-1, C-1, D-1, E-1, F-1, G-1-A, H-1, I-1-A & I-2-A

Tract C-1 - TR C-1 PLAT OF TRS A-1, B-1, C-1, D-1, E-1, F-1, G-1-A, H-1, I-1-A & I-2-A

Tract D-1 - TR D-1 PLAT OF TRS A-1, B-1, C-1, D-1, E-1, F-1, G-1-A, H-1, I-1-A & I-2-A

Tract E-1 - TR E-1 PLAT OF TRS A-1, B-1, C-1, D-1, E-1, F-1, G-1-A, H-1, I-1-A & I-2-A

Tract F-1 - TR F-1 PLAT OF TRS A-1, B-1, C-1, D-1, E-1, F-1, G-1-A, H-1, I-1-A & I-2-A

Tract G-1 - TR G-1-A PLAT OF TRS A-1, B-1, C-1, D-1, E-1, F-1, G-1-A, H-1, I-1-A & I-2-A

Tract I-1-A - TR I-1-A PLAT OF TRS A-1, B-1, C-1, D-1, E-1, F-1, G-1-A, H-1, I-1-A & I-2-A

Physical address of subject site:

5601 Balloon Fiesta Parkway, 9201 Balloon Museum Dr. NE

Subject site cross streets:

Alameda Road & Balloon Museum Drive

Other subject site identifiers:

Balloon Fiesta Park

This site is located on the following zone atlas page:

B-17-Z, C-16-Z, C-17-Z

Capitol

x





February 28, 2024

Re: Balloon Fiesta Park Master Development Plan/Site Plan for Subdivision and Site Plan-EPC

Landscape Architecture  
Urban Design  
Planning Services

Dear Neighbors:

302 Eighth St. NW  
Albuquerque, NM 87102

(505) 764-9801  
Fax 842-5495  
cp@consensusplanning.com  
www.consensusplanning.com

This letter provides notification that the Balloon Fiesta Park Development Plan/Site Plan for Subdivision and Site Plan-EPC for a United New Mexico Soccer Stadium was remanded to the Environmental Planning Commission (EPC) by the Land Use Hearing Officer (LUHO) following an appeal by adjacent neighborhood associations. As part of the remand, the City of Albuquerque is inviting neighbors to a facilitated meeting to discuss the request.

The facilitated meeting will be held on **Monday, March 4, 2024, from 5:30 to 7:30 pm.** Representatives from the City of Albuquerque and New Mexico United will be in attendance to answer any questions and listen to community input. The meeting will be facilitated by a City contractor and held online via Google Meet using the link below.

[meet.google.com/xec-uycp-xea](https://meet.google.com/xec-uycp-xea)

Join by phone +1 414-909-3864, PIN 106965974

The EPC hearing will be held on **Thursday March 21, 2024, starting at 8:40 am.** The public is invited to attend the hearing and provide input regarding this project, which will be held via Zoom using the link below:

<https://cabq.zoom.us/j/2269592859> or by calling the following number: 1 301 715 8592 and entering Meeting ID: 226 959 2859

If you have any questions or concerns, please do not hesitate to contact myself at [fishman@consensusplanning.com](mailto:fishman@consensusplanning.com) or you may also contact the City of Albuquerque Planning Department at [devhelp@cabq.gov](mailto:devhelp@cabq.gov).

PRINCIPALS

James K. Strozier, FAICP  
Jacqueline Fishman, AICP

ASSOCIATE

Ken Romig, ASLA

Sincerely,

Jacqueline Fishman, AICP  
Principal



OFFICIAL PUBLIC NOTIFICATION FORM
FOR MAILED OR ELECTRONIC MAIL NOTICE
CITY OF ALBUQUERQUE PLANNING DEPARTMENT



PART I - PROCESS

Use Table 6-1-1 in the Integrated Development Ordinance (IDO) to answer the following:
Application Type: Zone Map Amendment and Site Plan-EPC
Decision-making Body: City of Albuquerque Environmental Planning Commission
Pre-Application meeting required: [X] Yes [ ] No
Neighborhood meeting required: [X] Yes [ ] No
Mailed Notice required: [X] Yes [ ] No
Electronic Mail required: [X] Yes [ ] No
Is this a Site Plan Application: [X] Yes [ ] No Note: if yes, see second page

PART II - DETAILS OF REQUEST

Address of property listed in application: 9201 Balloon Museum DR NE; 4900 Balloon Fiesta PKWY NE; and 5601 Alameda NE
Name of property owner: City of Albuquerque
Name of applicant: Consensus Planning (agent); City of Albuquerque (co-applicant); New Mexico United (co-applicant)
Date, time, and place of public meeting or hearing, if applicable: EPC Hearing March 21, 2024 at 8:40 a.m.
Via Zoom- Meeting ID: 226 959 2859, or call in at (301) 715-8592
Address, phone number, or website for additional information: fishman@consensusplanning.com or 505-764-9801

PART III - ATTACHMENTS REQUIRED WITH THIS NOTICE

[X] Zone Atlas page indicating subject property.
[X] Drawings, elevations, or other illustrations of this request.
[ ] Summary of pre-submittal neighborhood meeting, if applicable.
[X] Summary of request, including explanations of deviations, variances, or waivers.

IMPORTANT: PUBLIC NOTICE MUST BE MADE IN A TIMELY MANNER PURSUANT TO SUBSECTION 14-16-6-4(K) OF THE INTEGRATED DEVELOPMENT ORDINANCE (IDO). PROOF OF NOTICE WITH ALL REQUIRED ATTACHMENTS MUST BE PRESENTED UPON APPLICATION.

I certify that the information I have included here and sent in the required notice was complete, true, and accurate to the extent of my knowledge.

[Signature] (Applicant signature) February 28, 2024 (Date)

Note: Providing incomplete information may require re-sending public notice. Providing false or misleading information is a violation of the IDO pursuant to IDO Subsection 14-16-6-9(B)(3) and may lead to a denial of your application.



**OFFICIAL PUBLIC NOTIFICATION FORM  
FOR MAILED OR ELECTRONIC MAIL NOTICE  
CITY OF ALBUQUERQUE PLANNING DEPARTMENT**



**PART IV – ATTACHMENTS REQUIRED FOR SITE PLAN APPLICATIONS ONLY**

Provide a site plan that shows, at a minimum, the following:

a. Location of proposed buildings and landscape areas.

b. Access and circulation for vehicles and pedestrians.

c. Maximum height of any proposed structures, with building elevations.

d. For residential development: Maximum number of proposed dwelling units.      N/A

e. For non-residential development:

Total gross floor area of proposed project.

Gross floor area for each proposed use.

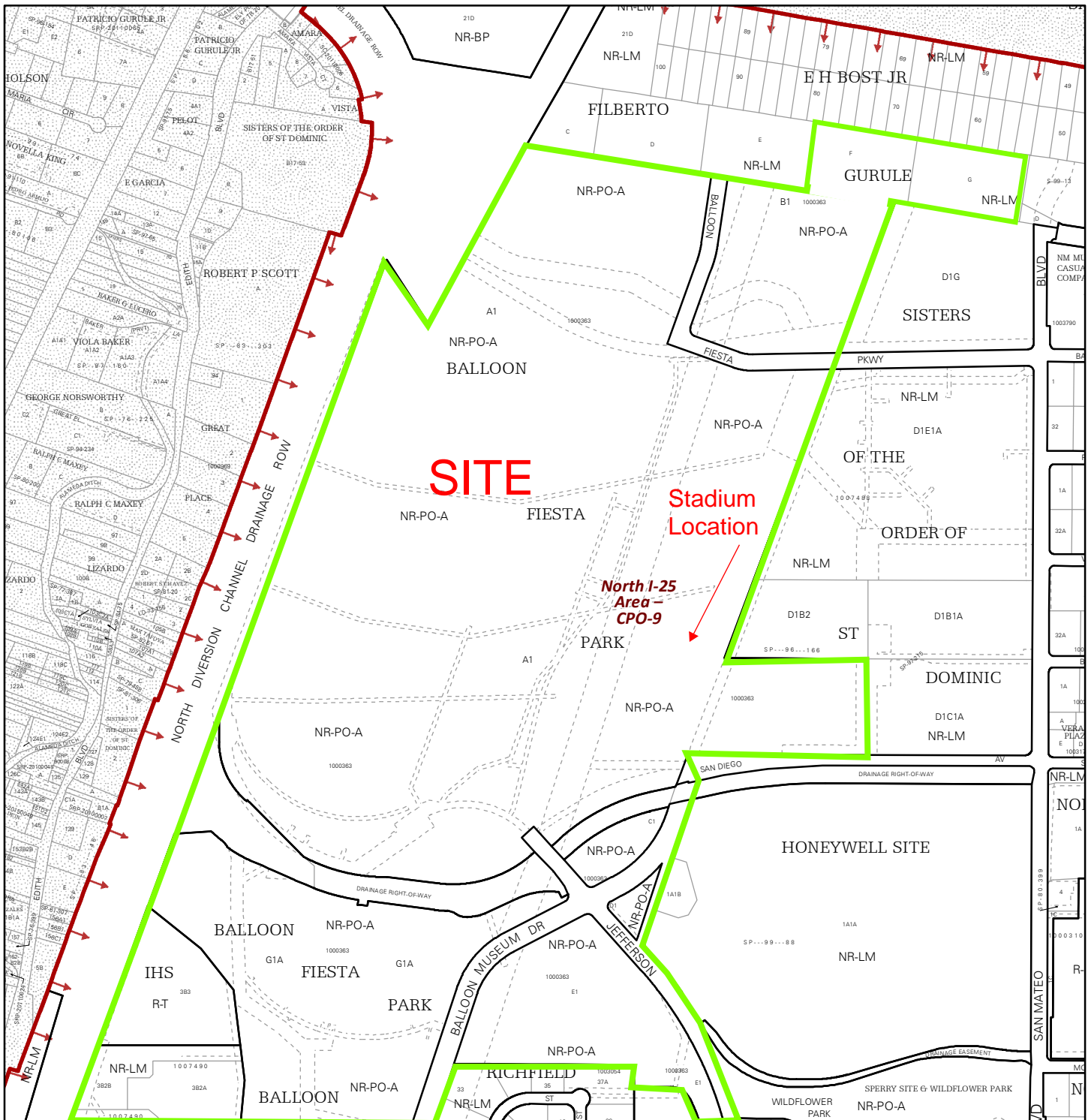

For more details about the Integrated Development Ordinance visit: <http://www.cabq.gov/planning/codes-policies-regulations/integrated-development-ordinance>

## IDO Zone Atlas May 2018

IDO Zoning information as of May 17, 2018  
The Zone Districts and Overlay Zones  
are established by the  
Integrated Development Ordinance (IDO).

Zone Atlas Page:  
**B-17-Z**

- Easement
- Escarpment
- Petroglyph National Monument
- Areas Outside of City Limits
- Airport Protection Overlay (APO) Zone
- Character Protection Overlay (CPO) Zone
- Historic Protection Overlay (HPO) Zone
- View Protection Overlay (VPO) Zone

Gray Shading  
Represents Area Outside  
of the City Limits

0 250 500 1,000 Feet



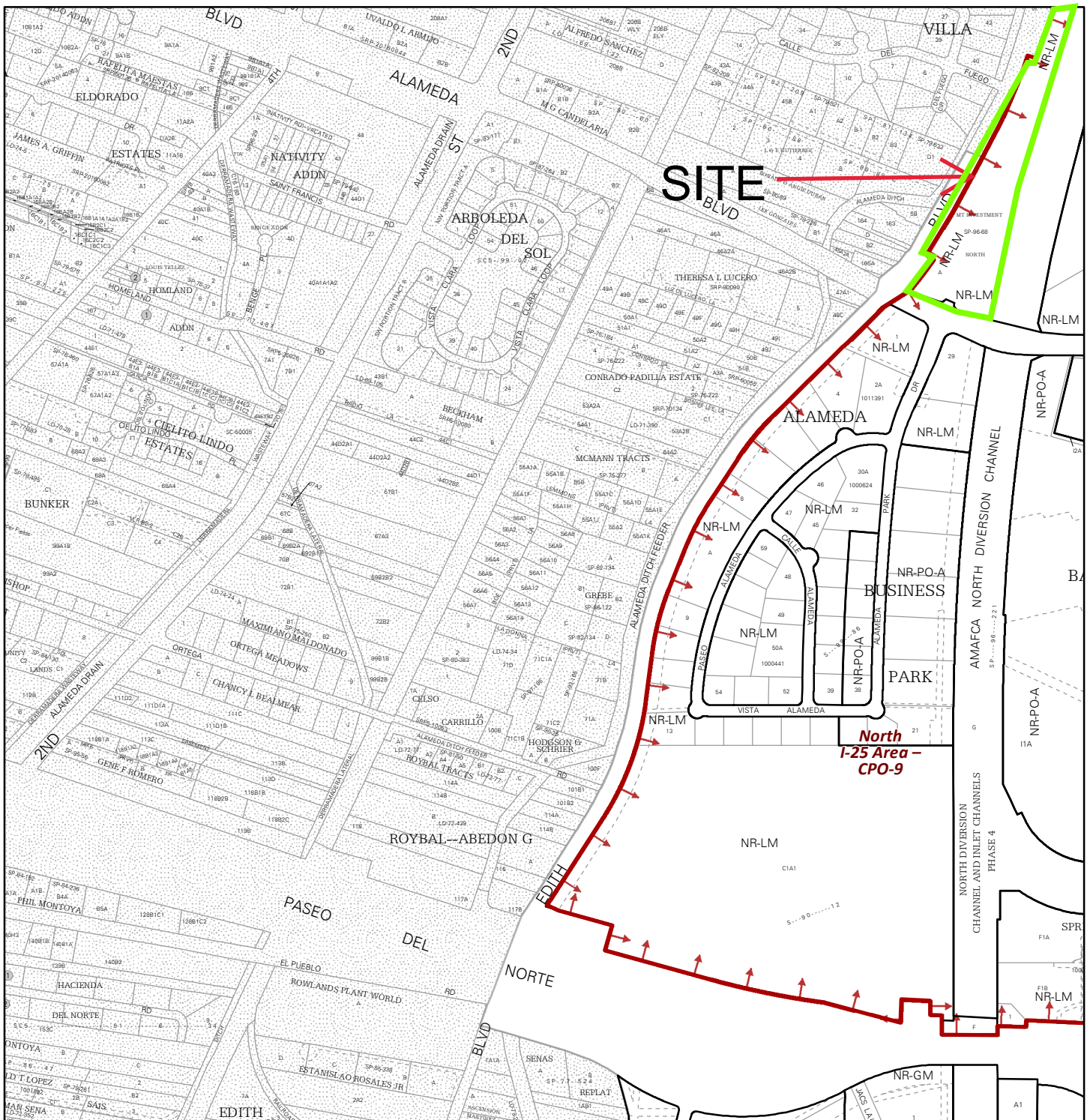

For more details about the Integrated Development Ordinance visit: <http://www.cabq.gov/planning/codes-policies-regulations/integrated-development-ordinance>

# IDO Zone Atlas May 2018

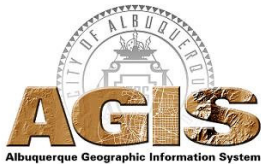

IDO Zoning information as of May 17, 2018  
The Zone Districts and Overlay Zones  
are established by the  
Integrated Development Ordinance (IDO).

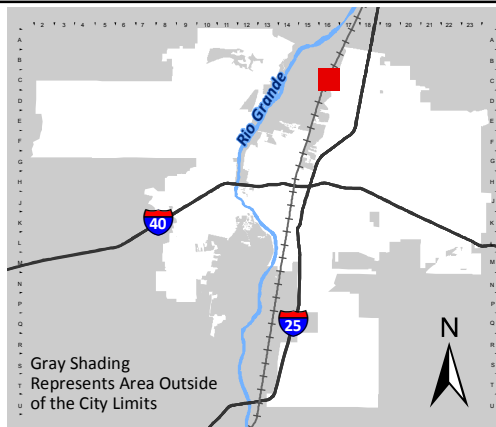

Zone Atlas Page:  
**C-16-Z**

- Easement
- Escarpment
- Petroglyph National Monument
- Areas Outside of City Limits
- Airport Protection Overlay (APO) Zone
- Character Protection Overlay (CPO) Zone
- Historic Protection Overlay (HPO) Zone
- View Protection Overlay (VPO) Zone

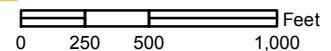



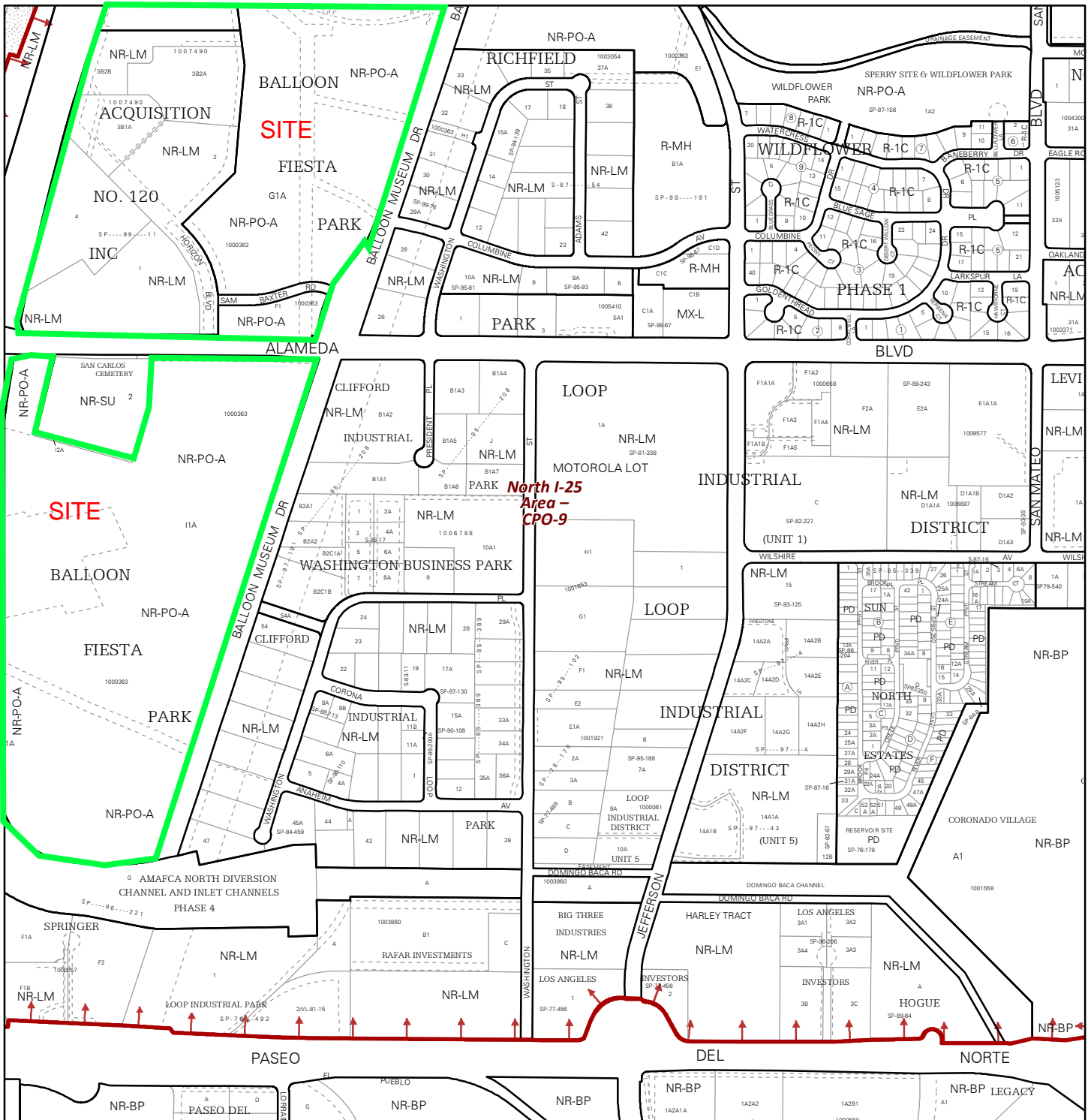

For more details about the Integrated Development Ordinance visit: <http://www.cabq.gov/planning/codes-policies-regulations/integrated-development-ordinance>







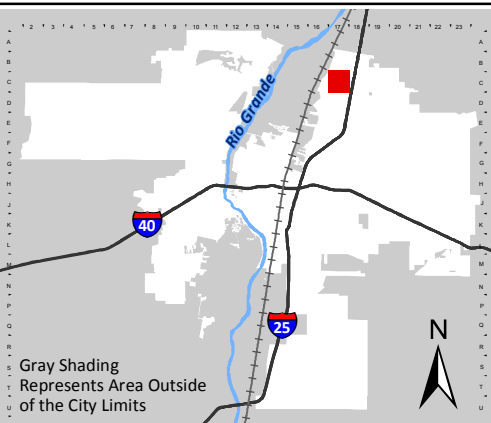

## IDO Zone Atlas May 2018



IDO Zoning information as of May 17, 2018  
The Zone Districts and Overlay Zones  
are established by the  
Integrated Development Ordinance (IDO).



Zone Atlas Page:  
**C-17-Z**

-  Easement
-  Escarpment
-  Petroglyph National Monument
-  Areas Outside of City Limits
-  Airport Protection Overlay (APO) Zone
-  Character Protection Overlay (CPO) Zone
-  Historic Protection Overlay (HPO) Zone
-  View Protection Overlay (VPO) Zone

0 250 500 1,000 Feet

[Note: Items with an asterisk (\*) are required.]

**Public Notice of a Proposed Project in the City of Albuquerque  
for Decisions Requiring a Meeting or Hearing  
Mailed to a Property Owner**

Date of Notice\*: February 28, 2024

This notice of an application for a proposed project is provided as required by Integrated Development Ordinance (IDO) [Subsection 14-16-6-4\(K\) Public Notice](#) to:

Property Owner within 100 feet\*: \_\_\_\_\_

Mailing Address\*: \_\_\_\_\_

**Project Information Required by [IDO Subsection 14-16-6-4\(K\)\(1\)\(a\)](#)**

1. Subject Property Address\* 9201 Balloon Museum DR NE; 4900 Balloon Fiesta PKWY NE; and 5601 Alameda NE  
Location Description Balloon Fiesta Park at Alameda Blvd and Balloon Museum Drive
2. Property Owner\* City of Albuquerque
3. Agent/Applicant\* *[if applicable]* Consensus Planning(agent); City of Albuquerque(co-applicant);New Mexico United (co-applicant)
4. Application(s) Type\* per IDO [Table 6-1-1](#) *[mark all that apply]*
  - Conditional Use Approval
  - Permit \_\_\_\_\_ (Carport or Wall/Fence – Major)
  - Site Plan
  - Subdivision \_\_\_\_\_ (Minor or Major)
  - Vacation \_\_\_\_\_ (Easement/Private Way or Public Right-of-way)
  - Variance
  - Waiver
  - Other: Amendment to BFP Master Development Plan

Summary of project/request<sup>1\*</sup>:

Two Part Request: Amendment to BFP Master Development Plan and Site Plan EPC

5. This application will be decided at a public meeting or hearing by\*:
  - Zoning Hearing Examiner (ZHE)
  - Development Review Board (DRB)
  - Landmarks Commission (LC)
  - Environmental Planning Commission (EPC)

<sup>1</sup> Attach additional information, as needed to explain the project/request.

[Note: Items with an asterisk (\*) are required.]

Date/Time\*: March 21, 2024 at 8:40 a.m.

Location\*<sup>2</sup>: Via Zoom - Meeting ID: 226 959 2859, or call in at (301) 715-8592

Agenda/meeting materials: <http://www.cabq.gov/planning/boards-commissions>

To contact staff, email [devhelp@cabq.gov](mailto:devhelp@cabq.gov) or call the Planning Department at 505-924-3860.

- 6. Where more information about the project can be found\*<sup>3</sup>:  
fishman@consensusplanning.com

**Project Information Required for Mail/Email Notice by [IDO Subsection 6-4\(K\)\(1\)\(b\)](#):**

- 1. Zone Atlas Page(s)\*<sup>4</sup> B-17-Z, C-16-Z, C-17-Z
- 2. Architectural drawings, elevations of the proposed building(s) or other illustrations of the proposed application, as relevant\*: Attached to notice or provided via website noted above
- 3. The following exceptions to IDO standards have been requested for this project\*:
  - Deviation(s)
  - Variance(s)
  - Waiver(s)

Explanation\*:

None requested.

- 4. A Pre-submittal Neighborhood Meeting was required by [Table 6-1-1](#):  Yes  No

Summary of the Pre-submittal Neighborhood Meeting, if one occurred:

Facilitated meeting to be held on March 4, 2024, at 5:30 pm using the following

link: [meet.google.com/xec-uycp-xea](https://meet.google.com/xec-uycp-xea)

Join by phone +1 414-909-3864, PIN 106965974

- 5. **For Site Plan Applications only\***, attach site plan showing, at a minimum:

- a. Location of proposed buildings and landscape areas.\*
- b. Access and circulation for vehicles and pedestrians.\*
- c. Maximum height of any proposed structures, with building elevations.\*

<sup>2</sup> Physical address or Zoom link

<sup>3</sup> Address (mailing or email), phone number, or website to be provided by the applicant

<sup>4</sup> Available online here: <http://data.cabq.gov/business/zoneatlas/>

[Note: Items with an asterisk (\*) are required.]

- d. **For residential development\***: Maximum number of proposed dwelling units.
- e. **For non-residential development\***:
  - Total gross floor area of proposed project.
  - Gross floor area for each proposed use.

**Additional Information:**

From the IDO Zoning Map<sup>5</sup>:

1. Area of Property [typically in acres] 367.5 acres
  2. IDO Zone District NR-PO-A
  3. Overlay Zone(s) [if applicable] North I-25 CPO-10
  4. Center or Corridor Area [if applicable] N/A
- Current Land Use(s) [vacant, if none] City Park
- 

**NOTE:** Pursuant to [IDO Subsection 14-16-6-4\(L\)](#), property owners within 330 feet and Neighborhood Associations within 660 feet may request a post-submittal facilitated meeting. If requested at least 15 calendar days before the public meeting/hearing date noted above, the facilitated meeting will be required. To request a facilitated meeting regarding this project, contact the Planning Department at [devhelp@cabq.gov](mailto:devhelp@cabq.gov) or 505-924-3955.

**Useful Links**

**Integrated Development Ordinance (IDO):**

<https://ido.abc-zone.com/>

**IDO Interactive Map**

<https://tinyurl.com/IDOzoningmap>

---

<sup>5</sup> Available here: <https://tinurl.com/idozoningmap>







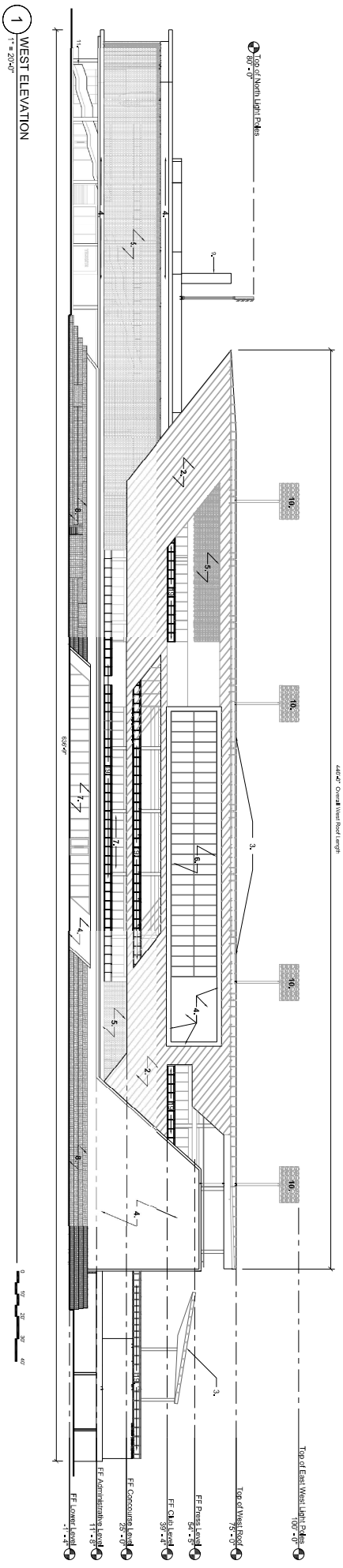

1 WEST ELEVATION  
1" = 20'-0"

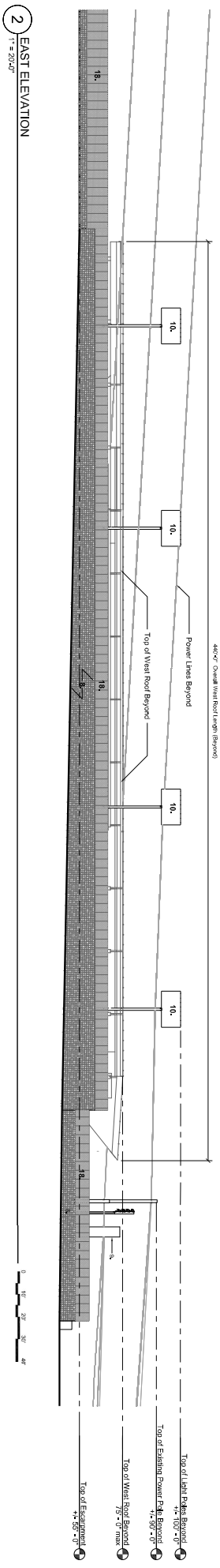

2 EAST ELEVATION  
1" = 20'-0"

**GENERAL NOTES**

- a. Finished floor heights are relative to field level (0'-0") which is equal to elevation 5056'.

**KEYED NOTES**

1. Precast Architectural Concrete Panels
2. Aluminum Profile Metal Panel System, Medium Gray Tone,
3. Standing Seam Metal Roof System
4. Aluminum Profile Metal Panel System, Yellow,
5. Kynar Aluminum Panel System Wall
6. Curtain Wall Clearing System
7. Stippled Clearing System
8. Screenboard
9. Screenboard
10. Light Poles
11. Monumental Steel Steel Structure
12. Monumental Steel Steel Structure
13. Aluminum Composite Metal Panel System, Grey
14. Sealing Bolt Beyond
15. Pedestrian Concrete Bridge
16. Pedestrian Concrete Bridge
17. Grass Barn Picnic Area
18. Pedestrian Fence, Heavy-Duty Wire Mesh and Perforated Panels, Metal Guardrail System, Sliver



**BALLOON FIESTA PARK  
MULTI-USE  
STADIUM**

**CITY OF ALBUQUERQUE**  
**PROJECT TEAM**  
 PLANNING AND ARCHITECTURE  
 CONSENSUS PLANNING  
 ARCHITECTURE  
 IMPROVE GROUP +  
 ODELL, A LABELLA COMPANY  
 ENGINEERING  
 BOHANNAN HOUSTON

**SITE DEVELOPMENT PLAN FOR BUILDING PERMIT  
 Building and Structure Elevations**

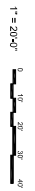

1" = 20'-0"

SHEET 9 OF 10  
OCT 5, 2023

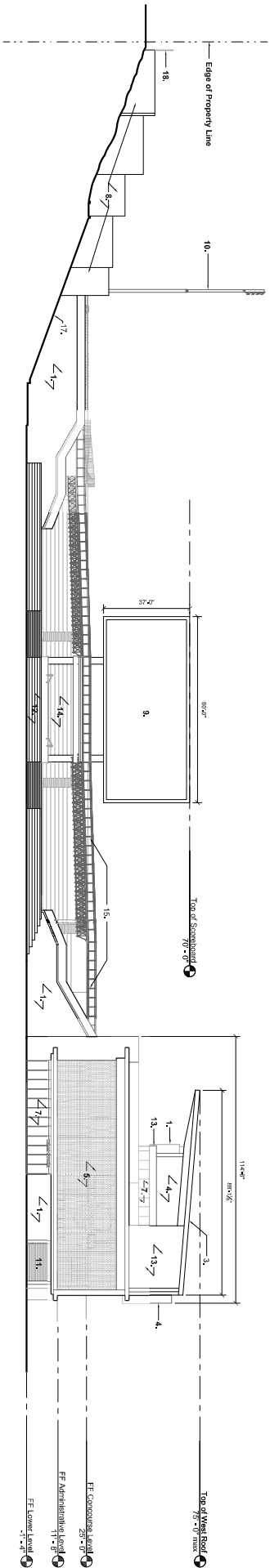

3 NORTH ELEVATION  
1" = 20'0"

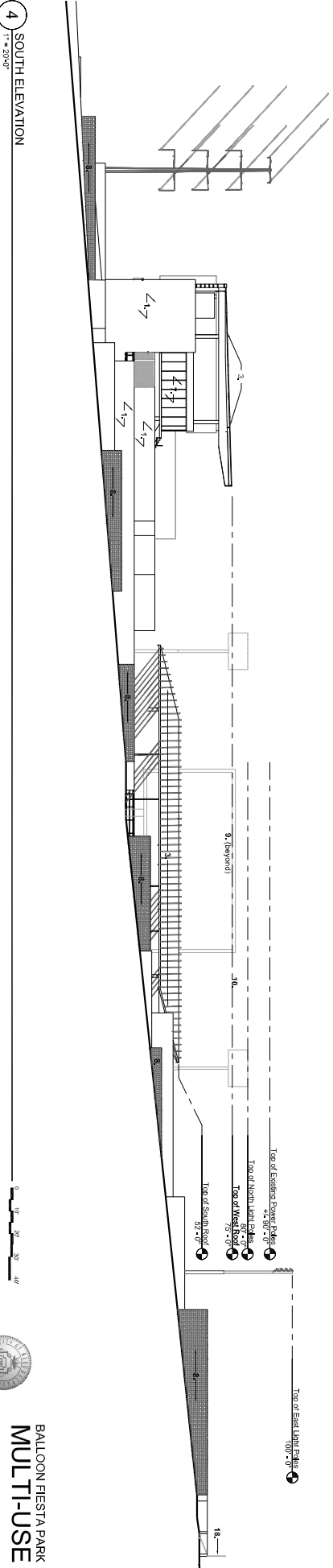

4 SOUTH ELEVATION  
1" = 20'0"

**GENERAL NOTES**

a. Finished floor heights are relative to field level (0'-0") which is equal to elevation 503'-2".

**KEYED NOTES**

1. Precast Architectural Concrete Panels
2. Aluminum Frame Metal Panel System, Medium Gray Tone
3. Aluminum Composite Metal Panel System, Yellow
4. Aluminum Composite Metal Panel System, Yellow
5. Kinetic Aluminum Panel Screen Wall
6. Kinetic Aluminum Panel Screen Wall
7. Curtain Wall Glazing System
8. Curtain Wall Glazing System
9. Curtain Wall System
10. Screen Wall System
11. Screen Wall System
12. Screen Wall System
13. Aluminum Composite Metal Panel System, Grey
14. Standing Seam Steel
15. Standing Seam Steel
16. Vehicle Gate
17. Grass Beam Paving Area
18. Painted Reinforced Concrete Wide Mesh and Perforated Panels
19. Metal Structural System, Slab



**BALLOON FIESTA PARK  
MULTI-USE  
STADIUM**

**CITY OF ALBUQUERQUE**  
**PROJECT TEAM**  
PLANNING AND ARCHITECTURE  
CONSENSUS PLANNING  
ARCHITECTURE  
IMPROVE GROUP +  
ODELL, A LABELIA COMPANY  
ENGINEERING  
BOHANNAN HUSTON

**SITE DEVELOPMENT PLAN FOR BUILDING PERMIT**  
**Building and Structure Elevations**



1" = 20'0"

SHEET 10 OF 10  
OCT 5, 2023

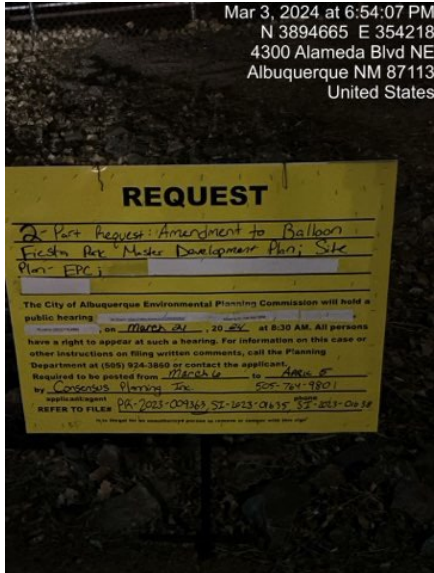

Figure 1: Alameda Blvd NE.



Figure 2: Alameda Blvd NE Sign #2



Figure 3: Balloon Fiesta Park at Jefferson Street NE.

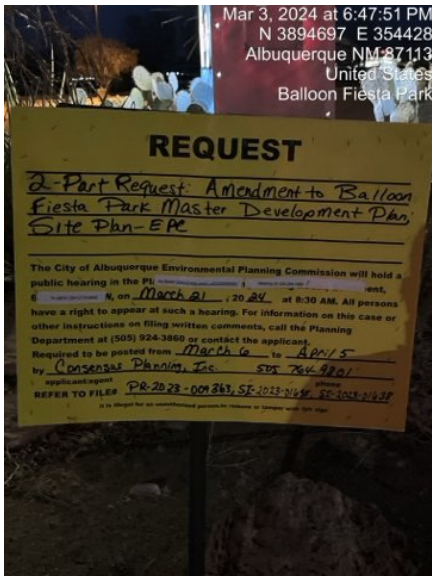

Figure 4: Balloon Fiesta Park Sign.



Figure 5: Balloon Fiesta Park Sign #2.



Figure 6: Balloon Fiesta Park Sign #3.



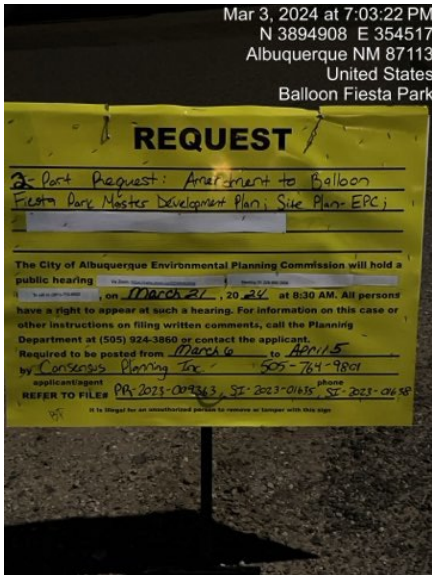

Figure 7: Balloon Fiesta Park Sign #4.

Figure 8: Balloon Fiesta Park Sign #5.



Figure 9: Balloon Fiesta Parkway Sign #1.

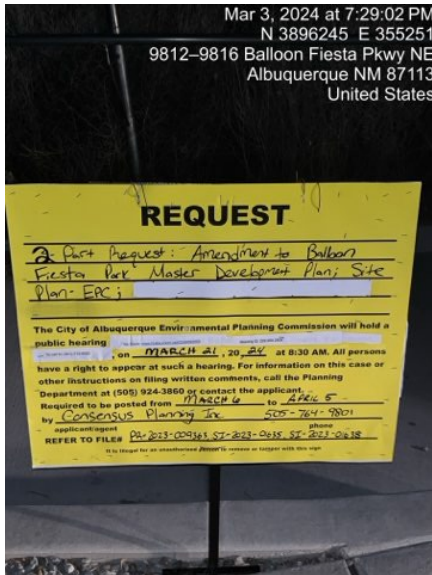

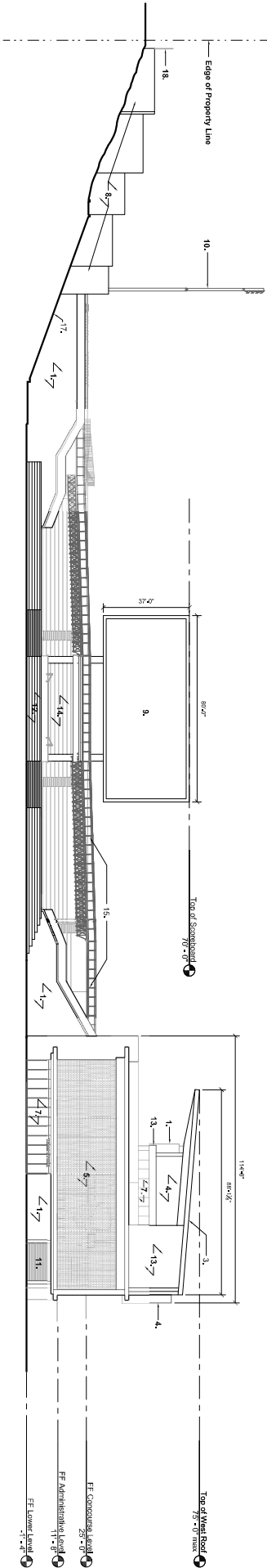



Figure 10: Edith Sign #1.

Figure 11: Edith Sign #2.





**3 NORTH ELEVATION**  
1" = 20'0"

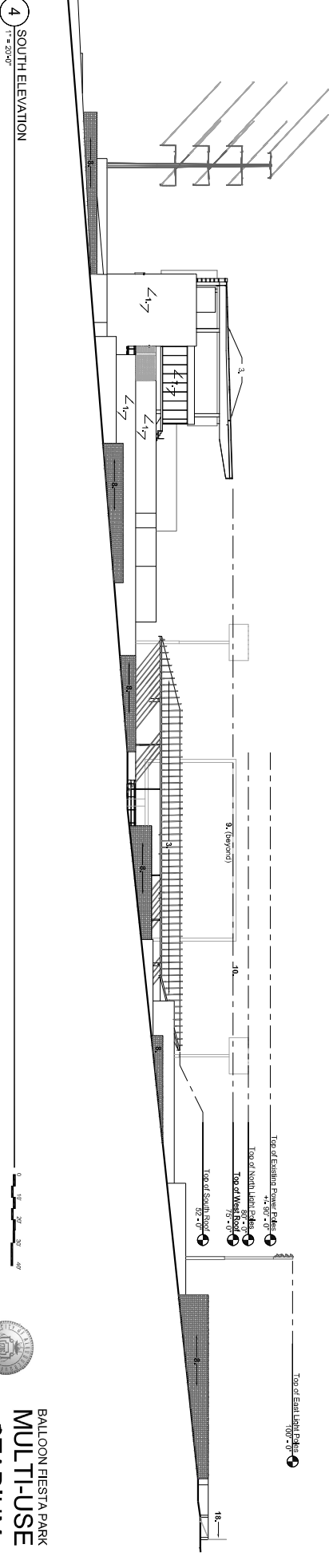

**4 SOUTH ELEVATION**  
1" = 20'0"

**GENERAL NOTES**

a. Finished floor heights are relative to field level (0'-0") which is equal to elevation 503.2'

**KEYED NOTES**

1. Precast Architectural Concrete Panels
2. Aluminum Frame Metal Panel System, Medium Gray Tone
3. Aluminum Composite Metal Panel System, Yellow
4. Aluminum Composite Metal Panel System, Yellow
5. Kinetic Aluminum Panel Screen Wall
6. Kinetic Aluminum Panel Screen Wall
7. Curtain Wall Glazing System
8. Curtain Wall Glazing System
9. Curtain Wall System
10. Screen Wall System
11. Screen Wall System
12. Screen Wall System
13. Aluminum Composite Metal Panel System, Grey
14. Standing Seam Steel
15. Standing Seam Steel
16. Vehicle Gate
17. Grass Beam Paving Area
18. Painted Reinforced Concrete Wide Mesh and Perforated Panels
19. Metal Structural System, Slab



**BALLOON FIESTA PARK  
MULTI-USE  
STADIUM**

**CITY OF ALBUQUERQUE**  
**PROJECT TEAM**  
PLANNING AND ARCHITECTURE  
CONSENSUS PLANNING  
ARCHITECTURE  
IMPROVE GROUP +  
ODELL, A LABELIA COMPANY  
ENGINEERING  
BOHANNAN HUSTON

**SITE DEVELOPMENT PLAN FOR BUILDING PERMIT**  
**Building and Structure Elevations**



SHEET 10 OF 10  
OCT 5, 2023







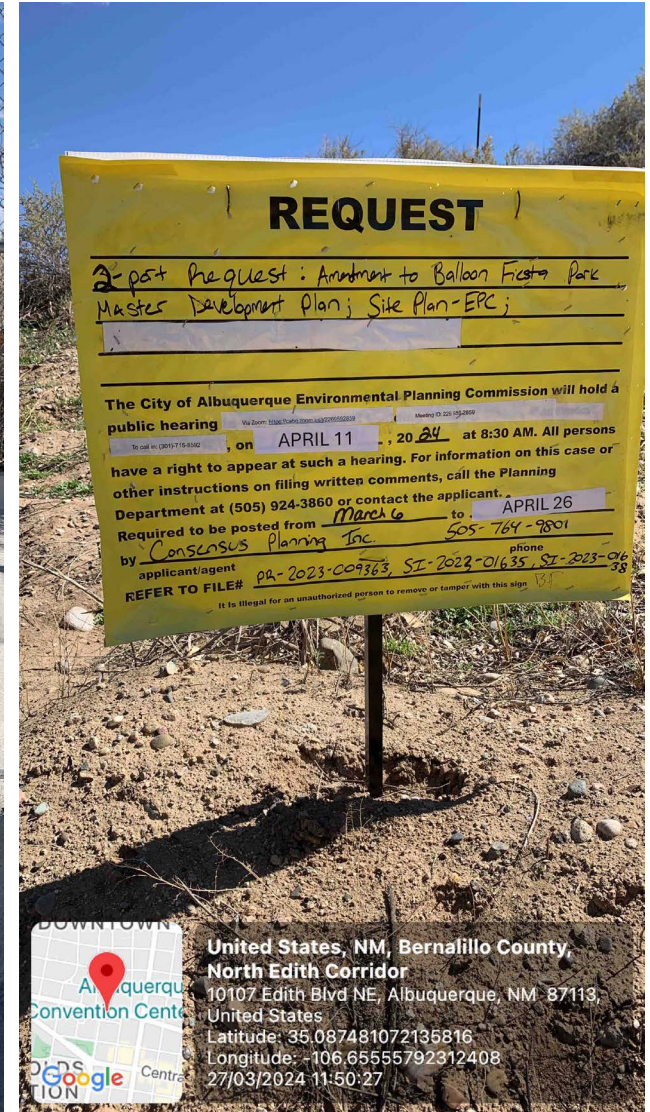
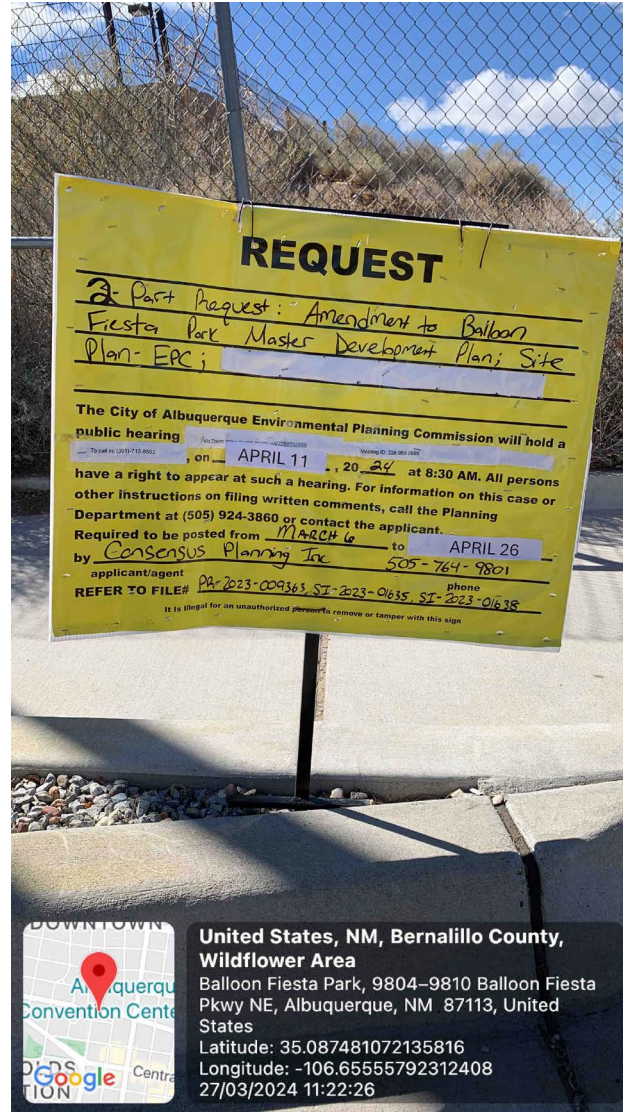







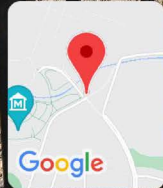

United States, NM, Bernalillo County,  
Wildflower Area  
Balloon Fiesta Park, N Diversion Channel Trail,  
Albuquerque, NM 87113, United States  
Latitude: 35.19129570653425  
Longitude: -106.59433757225571  
27/03/2024 14:51:47

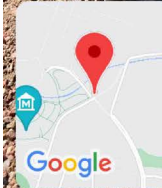
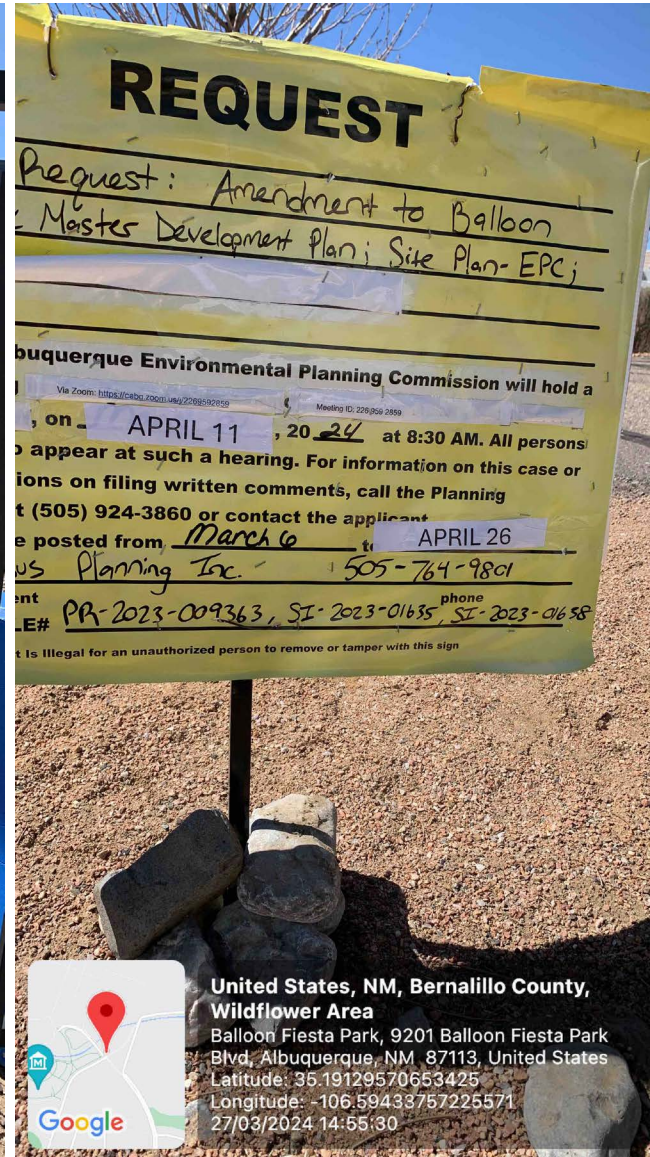

United States, NM, Bernalillo County,  
Wildflower Area  
Balloon Fiesta Park, 9201 Balloon Fiesta Park  
Blvd, Albuquerque, NM 87113, United States  
Latitude: 35.19129570653425  
Longitude: -106.59433757225571  
27/03/2024 14:55:30

POST-LUHO HEARING

FACILITATED MEETING

MARCH 4, 2024

# CITY OF ALBUQUERQUE

## LAND USE FACILITATION PROGRAM PROJECT MEETING REPORT

**Project #:** PR-2023-009363

**Property Description/Address:** Balloon Fiesta Park at Alameda and Balloon Museum Drive NE

**Date Submitted:** 5 March 2024

**Submitted By:** Philip Crump

**Meeting Date/Time:** Monday 4 March 2024, 5:30-7:40 pm

**Meeting Location:** Via Google Meet

**Facilitator:** Philip Crump

**Applicant/Agent:** City of Albuquerque and New Mexico United Soccer/Consensus Planning

**Neighborhood Associations/Interested Parties:** North Valley Coalition, Alameda North Valley Association, Maria Dies NA, Wildflower Area NA, North Edith Corridor Association

### **Background/Meeting Summary:**

This was the second facilitated meeting held regarding the proposed stadium application—a request for change to the Balloon Fiesta Park Master Development Plan and the site plan for the stadium.. Several additional non-facilitated meetings have been held since the first facilitated meeting in September. This meeting was held due to a mistake in the notification process for the EPC hearing; the Land Use Hearing Officer was asked to remand the project back to the EPC. The NM United President said they want to be good neighbors and find collaborative solutions to the issues raised by neighbors.

Attendees at this meeting included many residents of nearby neighborhoods and were overwhelmingly in opposition to the proposed stadium. They cited issues regarding noise, lighting, traffic, as well as intensity of proposed uses at the stadium. The planning team referred to ongoing studies, especially of light and noise, and possible changes to the stadium design to mitigate potential negative impacts on the surrounding residents.

### **Outcome:**

Neighbors were firm in their opposition to the application, while the planning team and NM United indicated continuing efforts to mitigate negative impacts.

### **Meeting Specifics:**

#### **1) Purpose of meeting**

- a) The first EPC hearing for this case was held 16 November 2023.
- b) There was a mistake in not notifying several adjacent property owners about the hearing
  - i) The mistake was unintentional on the part of the planners.
- c) This meeting was for listening to concerns and reporting on any updates in the proposal.

#### **2) Updates to the proposal**

- a) The height of the west side of the stadium is to be reduced to nearly the height of the escarpment on the east side.
- b) The roof over the west side is to be extended.
  - i) The purpose of these changes is to reduce fugitive light and sounds to the greatest extent possible.
- c) The planners are engaged in additional conversations with the sound consultants .
  - i) They will be doing additional analysis of the design and looking into other ways to better reduce any sort of sound impact that the stadium would have .
    - (1) They are looking into additional studies and tests to further refine the design.

#### **3) Issue—Noise**

- a) Neighbors are concerned about noise from several sources at the stadium.
  - i) Crowd noise, amplified noise, airhorns, and fireworks are potential problems.
- b) The architect said lowering the height of the stadium and extending the roof would mitigate escaping noise.

# CITY OF ALBUQUERQUE

## LAND USE FACILITATION PROGRAM PROJECT MEETING REPORT

- i) Limiting fireworks is a matter for discussion to which NM United is open.
  - ii) They are engaging the sound consultants to more accurately analyze the design and determine the sound levels that might emanate from the stadium.
  - c) The owner said that they can limit amplified noise.
    - i) They will comply with the City's Sound Ordinance.
  - d) A neighbor said that a real concern is amplification.
    - i) "The Golf Center has numerous weddings and Quinceañeras; as soon as the band starts up my life is changed."
  - e) The NM United President said that they are working to figure out how to engineer it properly so the sound pushes North where there are no residences.
    - i) The architect said they have crowd noise buffered by design, but that amplification is another matter.
      - (1) Crowd sounds will come from the west side of the stadium, directed to the northeast.
      - (2) They will use a distributed speaker system that does not have to be so loud for everyone in the stadium to hear.
        - (a) The sound will have to be kept at 90dB or less, measured at the center of the stadium.
          - (i) Another neighbor said 90 decibels is actually at a level that can induce hearing damage in people.
  - f) A question was raised as to whether a complete roof could be installed over the stadium.
    - i) NM United responded that it would be too expensive.
  - g) Another neighbor asked whether the sound study had looked at the contributions of the Albuquerque Box to the distribution of sound.
    - i) The architect said they were working with the sound consultant to conduct live tests, with monitoring equipment around the neighborhoods to test the actual distribution of sound.
- 4) Issue—Light**
- a) A neighbor expressed concern about light emanating from the stadium.
    - i) She said that it would be visible from some residents' houses and interfere with their views of the mountains.
    - ii) The architect said all the light fixtures will be aimed downward to prevent light escaping the stadium.
      - (1) The lighting consultant they work with has been involved with Dark Skies communities for many types of facilities.
        - (a) They will ensure that 99% of the light stays within the stadium.
        - (b) Lights will be turned down when games finish—around 9 pm.
    - iii) Referring to the architect's photo of the lighted stadium in Colorado Springs, he said it sits in a hole, unlike this proposed facility.
      - (1) He also said that a friend who lives nearby told him ..."when they turn the lights on I can mow my lawn and my backyard"
    - iv) There will be no pole lighting in the parking areas—only pedestrian illumination like light bollards.
- 5) Issue—Traffic and parking**
- a) Neighbors are concerned about traffic cutting through neighborhoods.
    - i) NM United will hire APD officers for traffic control and possibly erect barriers to prevent traffic from coming through or parking in adjacent streets.
  - b) During Balloon Fiesta, as many as 13,000 cars are entering the area, bringing up to 100,000 people per day.
    - i) NM United anticipates as many as 3,000 cars, bringing up to 10,000 people.



# CITY OF ALBUQUERQUE

## LAND USE FACILITATION PROGRAM PROJECT MEETING REPORT

- ii) Non-Fiesta events such as Wine Festival or 4<sup>th</sup> of July bring in people not used to the area, who come through neighborhoods and create unsafe conditions.
    - (1) For soccer games, many of the attendees will be season ticket-holders, who will use the north access to the stadium.
      - (a) NM United will provide access and parking directions to ticket holders.
    - (2) Parking will be adjacent to the stadium.
  - c) Traffic is going to be principally using Balloon Fiesta Parkway, which is multi-lane.
    - i) NM United has the ability to control the traffic.
      - (1) They will make every efforts to coordinate that so that there is no traffic flowing through Wildflower Community.
- 6) Issue—Intensity of uses**
- i) A neighbor said that the facility is advertised by the city as a multi-use stadium.
    - (1) This means there will be more than soccer happening there; we need to have a clearer idea of the intensity of the uses.
    - (2) “It’s one thing to say 17 home games a year. It’s another thing to have a hundred different events throughout the year.”
      - (a) The NM United President said that events would be held on weekends—whether soccer or other events.
      - (b) The business plan does not include a lot of non-soccer events.
        - (i) Right now there is no clear idea of what or how many non-soccer events would be held.
  - ii) One resident suggested that given the sizeable investment—a minimum of \$30 million is required by the terms of the lease—there is incentive to hold many events at the stadium.
    - (1) NM United understands costs and risks of non-soccer events.
      - (a) There likely will be more smaller events.
      - (b) They want this to be a community asset.
- 7) Issue—Lease agreement**
- a) Neighbors wanted to know whether the lease could be modified to reflect community wishes.
    - i) One said that it is too simplistic and vague.
      - (1) “If you have uses out there that aren’t enumerated or prohibited or spelled out in the lease. what protections do we have?”
  - b) One neighbor said that even though she is opposed to the stadium, changes to lease agreement might lessen the negative impacts on the surrounding area.
  - c) Another neighbor said that in the lease the tenant agrees to develop a “community benefits program.”
    - i) She asked for more information about how NM United will work with the community.
      - (1) A City staffer suggested that it means the overall effort is to be of net benefit to the community.
        - (a) It is usually not a breakdown analysis of specific contractual rights and obligations but rather is aspirational—and a bit ambiguous.
  - d) She said that whether you put a roof or a partial roof or no roof, it may not contain all the noise.
    - i) What would be the avenue to report or register an immediate complaint?
      - (1) Another neighbor said that at other City facilities, there is no expectation that Parks and Recreation would respond to a complaint after working hours.
        - (a) They keep telling us that they’re going to work on the noise and watch the decibel level and to meet the Sound Ordinance and things like that, but nothing happens.
      - (2) Would NM United monitor during games to know that you are not complying with the ordinance?
        - (a) NM United will have a person on duty to respond to calls.

# CITY OF ALBUQUERQUE

## LAND USE FACILITATION PROGRAM PROJECT MEETING REPORT

- e) One person asked whether the lease agreement could eliminate alcohol sales.
  - i) It is a problem in this area and in Albuquerque.
  
- 8) **Issue—Meeting notification**
  - a) Several people complained about the short notice given for this meeting.
  - b) A resident said they were given three business days' notice to have this meeting.
    - i) He said planners should typically give a minimum of 14 days or 30 days' notice for a meeting.
      - (1) That same short period of time is going to confront them with the EPC meeting.
  - c) Another said that while the planning team talks about collaboration and working with neighbors, the request to postpone this meeting to a later date were ignored.
  
- 9) **Issue—Business plan**
  - a) A neighbor asked whether the business plan had been submitted along with the application.
    - i) If so, it would be a public document available for review by citizens.
    - ii) If it is being used as the basis for future uses, it would be better for everyone to see a written document rather than just hear spoken words.
  - b) A planner said it was not submitted with the application.
    - i) NM United agreed that if it were submitted, it would be open to the public, but that it is a private document and not a part of the public submission.
      - (1) The owners will be asked whether such information could be shared.
  
- 10) **Issue—Alternate location**
  - a) People asked whether the stadium could be built in a different location, away from residents.
    - i) One person asked why this site was chosen and asked that NM United change their mind.
    - ii) Q: Why not look to other areas?
      - (1) There are places like where the team is currently practicing--Mesa Del Sol.
      - (2) There also are areas off the Rio Puerco.
      - (3) There are places that are close to I-40 that allow people to access without ruining a community.
      - (4) There is Rio Rancho, a crime-free community lauded all the time about one of the best places to live.
  - b) The owner said they had looked at a number of other locations.
    - i) Major League Baseball likely would not permit their continuing use of the Isotopes' stadium.
    - ii) They really wanted a downtown location, for positive economic impact in that area, but were voted down.
    - iii) Places they looked at did not have the infrastructure or parking area or access/
      - (1) Balloon Fiesta Park has access and infrastructure already and is a good location for Albuquerque citizens and fans.
  
- 11) **Issue—Opposition**
  - a) A nearby resident said that there are 70 people who signed on to the appeal, and that more indicated they were also in opposition to the stadium.
  - b) Many meeting attendees indicated verbally or in the Chat that they are opposed to the application.
  - c) Several people said they lived in that area because it is a quiet rural area and they do not want it disturbed.
    - i) "...the soccer stadium is not in harmony with our neighborhood, which is completely rural--small farms and livestock..."
      - (1) "...There are a lot of things about Alameda that are important and there's nothing in anybody's view of the community of Alameda that includes a soccer stadium..."

# CITY OF ALBUQUERQUE

## LAND USE FACILITATION PROGRAM PROJECT MEETING REPORT

### 12) Community engagement

- a) Several people referred to comments from the planning team about collaboration.
  - i) One asked why there's not a Roundtable discussion where NM United and neighbors can meet and discuss and say let's work these things out.
  - ii) Another asked that they be listened and responded to.
- b) NM United President Ron Patel invited neighbors to contact him for additional discussion. He said he can be reached at [ron@newmexicoutd.com](mailto:ron@newmexicoutd.com).
- c) The owner said they in the list of issues, there may be some things they can do and maybe some things they cannot do.
  - i) They are ready to have that discussion so neighbors can understand what points there are where they all can work on a compromise.
    - (1) That would be so if it is built, it is done in a way that has minimal impact on the community not maximum negative impact.

### 13) Other issues

- a) It was pointed out that the Balloon Fiesta Park Master Development Plan does not allow a stadium.
  - (1) That is one major part of the application.
  - ii) One realtor said she thought the stadium might depress home values in the area.
    - (1) The NM United owner disagreed, saying that the development of amenities can enhance property values.
- b) The question was asked whether the stadium is a "done deal."
  - i) The owner said it is not a done deal.

### EPC Application Hearing Details:

EPC Hearing scheduled for (3<sup>rd</sup> Thursday date—21 March 2024)

- 1. Hearing Time:
  - a. All meetings are currently held via Zoom: <https://cabq.zoom.us/j/2269592859>
  - b. Agenda and staff reports will be posted on the EPC website on 14 March 2024--  
<https://www.cabq.gov/planning/boards-commissions/environmental-planning-commission/epc-agendas-reports-minutes>
  - c. The Commission will begin hearing applications at 8:30 a.m.
  - d. The actual time this application will be heard by the Commission will depend on the applicant's position on the Commission's schedule
- 2. Hearing Process:
  - a. Comments from facilitated meetings will go into a report which goes to the City Planner.
  - b. City Planner includes facilitator report in recommendations.
  - c. The Commission will make a decision and parties have 15 days to appeal the decision.
- 3. Resident Participation at Hearing:
  - a. All written materials - including petitions, legal analysis, and other documents - should ordinarily be submitted at least 10 days prior to the public hearing to the Staff Planner Silvia A. Bolivar [sabolivar@cabq.gov](mailto:sabolivar@cabq.gov) and to [PlanningEPC@cabq.gov](mailto:PlanningEPC@cabq.gov), ensuring presentation at the EPC hearing.
    - i. OR mailed to EPC Chair, c/o Planning Department, 600 2<sup>nd</sup> St., 3<sup>rd</sup> floor, Albuquerque, NM 87102

### Names & Affiliations of Attendees (and additional Interested Parties):

Ron Patel	Pres, NM United
Peter Trevisani	Owner, NM United
Jackie Fishman	Consensus Planning
Charlene Johnson	Consensus Planning

# CITY OF ALBUQUERQUE

## LAND USE FACILITATION PROGRAM PROJECT MEETING REPORT

Jared Winchester	Improve Group
David Flores	CABQ Parks & Rec Dep Dir
Michael Haederle	VP, North Edith Corridor Ass'n
Maggie Rose	Pres, Maria Diers NA
Steve Wentworth	Alameda North Valley NA
Andrea Folk	
Ashley Banegas	
Bari Harvey	
Brooke Jordy	
Chris Michel	
Christine Benavides	
Courtney Johnson	
David Wiese-Carl	
Flowerlillyd	
Isaiah Urrutia	
Jackie Lance	
Jason Chavez	
Jason Libersky	
Jay Hone	
Jennifer Robinson	
L Gonzales	
Larrea Lavoiscia	
Laura Tweed	
Leslie Linthicum	
Lorraine Montoya	
Luis B Tafoya	
Manuela Mondloch	
Matthew G. F. Dosanjh	
Oscar Simpson	
Pat Hauser	
Paul Barricklow	
Peggy Norton	
Regina Cooper	
Regina Jolley	
Russ Harvey	
Sarah Heartt	
Sarah Shortle	
Steve & Annette Kitts	
Tania Gonzalez	
Tina Villegas	
Tony Lovato	
Victoria Odell	
Tyson Hummell	CABQ ADR Coordinator
Philip Crump	Facilitator



# CITY OF ALBUQUERQUE

## AMENDMENT to Land Use Facilitated Meeting Report

**Project:** NM United Stadium at Balloon Fiesta Park

**Meeting Date and Time:** Monday 4 March 2024, 5:30-7:40 pm

**Date Submitted:** 7 March 2024

**Original Submission:** 5 March 2024

**Submitted By:** Philip Crump

**Facilitator:** Philip Crump

*Corrections/changes/additions are shown in **BOLD**.*

### 5) Traffic and parking

- c. Traffic is going to be principally using Balloon Fiesta Parkway, which is multi-lane.
  - i) NM United has the ability to control the traffic.
    - (1) They will make every efforts to coordinate that so that there is no traffic flowing through Wildflower Community.
    - (2) **Parking on nearby streets would be a problem if there is only paid parking on site.**

### 6) Intensity of uses

- i) A neighbor said that the facility is advertised by the city as a multi-use stadium.
  - (1) This means there will be more than soccer happening there; we need to have a clearer idea of the intensity of the uses.
  - (2) “It’s one thing to say 17 home games a year. It’s another thing to have a hundred different events throughout the year.”
    - (a) The NM United President said that events would be held on weekends—whether soccer or other events.
    - (b) The business plan does not include a lot of non-soccer events.
      - (i) Right now there is no clear idea of what or how many non-soccer events would be held.
      - (ii) **It could be as many as 100 events a year, including birthday parties and quinceañeras.**
        - 1. **That is a lot, though NM United cannot commit to a number.**
        - 2. **Additionally, the City will have a lot of events, though that number is also not known.**

### 10) Issue—Alternate location

- a. People asked whether the stadium could be built in a different location, away from residents.
  - i) One person asked why this site was chosen and asked that NM United change their mind.
  - ii) Q: Why not look to other areas?
    - (4) There is Rio Rancho, a crime-free community lauded all the time about one of the best places to live.
    - (5) **One person in the chat suggested that the University Sports Complex area.**
      - (a) **Another wrote that successful stadiums are sited near other stadiums.**

LETTERS OF SUPPORT

**From:** [Amy Rehfeld](#)  
**To:** [Bolivar, Silvia A.](#)  
**Subject:** Support of NM United Stadium  
**Date:** Monday, April 1, 2024 10:32:09 AM

---

[EXTERNAL] Forward to [phishing@cabq.gov](mailto:phishing@cabq.gov) and delete if an email causes any concern.

Jonathan R Hollinger, Chair  
Environmental Planning Commission  
City of Albuquerque  
600 Second Street NW  
Albuquerque, NM 87102

Dear Mr. Hollinger,

I support the NM United Stadium construction. The organization needs a permanent stadium or WE will lose this great sports team. New Mexico United match attendance averages 10,000, which shows the community support. The franchise is one of the top performers both in winning matches and attendance in the league. Other than the Isotopes, NM United is our state's only other VIABLE and professional sports team. Soccer is the fastest growing sport in our country and is used as a marketing tool to recruit businesses to our area.

The stadium will improve Ballon Fiesta Park usage by activating it year-round, as opposed to only nine days per year for the International Balloon Fiesta and bring much needed infrastructure improvements.

Sincerely,

Amy Rehfeld  
4313 Hannett NE  
Albuquerque, NM 87110  
505-235-0663=

Andrew Hageman, 1357 Summit Hills Dr NE, Albuquerque NM87112

Ref: Balloon Fiesta Park / New Mexico United Stadium proposal

Dear Jonathan R. Hollinger,

03/05/2024

I write in reference to the appeal of the EPA vote to approve the stadium conversion of 7 acres of derelict land to become the home of a local pro soccer stadium.

Firstly, I am in full support of this opportunity to give the local team a real home. After all, New Mexico has very few world class venues and since we are mostly at the bottom of the 'good lists' and atop the 'bad ' lists, I cannot think of a better way to use this undesirable plot which forms part of 360 acres of AIBF land.

- 1) The clever sunken design will almost illuminate noise pollution to local properties.
- 2) The cars and their occupants would cause far less trauma to local residents than an average day at the balloon fiesta.
- 3) The stadium will be sold to the City after NM United have finished using it – for just a dollar!
- 4) The team have proven the concept that the team is worthy, well supported, and above all – responsible local partners who do great things for the community.
- 5) The rent the team will pay will benefit all City residents.
- 6) Balloonists will not be affected because the derelict 7-acre plot has power lines nearby so pilots couldn't land there even if they wanted to.
- 7) The "not in my back yard" mentality is all very well but there has been nil to zero arrests around Isotopes Park before, during or after games there in 5 years. The arguments 'against' are just fear and not based on real data or plausible concerns.
- 8) The local businessman who own United may well jump ship to Rio Rancho or beyond if they cannot make a home locally.
- 9) Local youth (both of all genders) can be part of the teams future with the well established and successful Academy (funded by the Somos Unidos Foundation) and there is every chance the team will add a professional women's soccer team once a home has been established.

Doesn't the future generation following us not need and deserve some facilities to enhance and encourage them to stay local?

I am disabled, made so by a hospital blunder. When I was at my lowest the team invited me to be one of their commentators for live broadcasting on the local sports radio station. They plucked me from the gloom and gave me a chance to shine on air. They have accommodated my needs and supported me throughout five years (so far) and I cannot fault the team, the spirit of the fans and above all what they have given back to



Albuquerque. The team have said they will be good neighbors and nothing I have seen from the organization gives me any doubt that they are genuinely intent on being a benefit to ALL like their logo suggests...in 'Uniting' New Mexico and our great city.

Please, when the time comes to vote, be on the right side of this and history and allow Albuquerque the opportunity to enhance the lives of many and improve the area.

Yours sincerely,

Andrew Hageman

**Bolivar, Silvia A.**

---

**From:** Andy Hageman <andyhageman@comcast.net>  
**Sent:** Tuesday, March 5, 2024 8:05 AM  
**To:** Bolivar, Silvia A.  
**Subject:** Copy of letter mailed to Jonathan Hollinger attached  
**Attachments:** UNITED EPC.docx

[EXTERNAL] Forward to [phishing@cabq.gov](mailto:phishing@cabq.gov) and delete if an email causes any concern.

Dear Silvia Bolivar, please pass to Mr. Hollinger, thank you.

Hard copy in USPS Mail.

Andy Hageman

## Bolivar, Silvia A.

---

**From:** Danette Medina <danettemedina@yahoo.com>  
**Sent:** Monday, March 4, 2024 11:26 AM  
**To:** Bolivar, Silvia A.  
**Subject:** New Mexico United Soccer Stadium

[EXTERNAL] Forward to [phishing@cabq.gov](mailto:phishing@cabq.gov) and delete if an email causes any concern.

Jonathan R. Hollinger, Chair  
Environmental Planning Commission  
City of Albuquerque  
600 Second Street NW  
Albuquerque, NM 87102  
But please send the letters to Silvia

Dear Chairman Hollinger and the Environmental Planning Commission Members:

My name is Danette Medina and I am writing in support of New Mexico United Soccer and their proposed Stadium. I do live close to the proposed stadium site in the North Valley (4th street and Ranchitos area.)

As someone who is passionate about soccer, I believe this project has the potential to make a real impact in our city and State.

New Mexico United has developed an innovative and effective plan for a soccer stadium. The potential impact of this Stadium project is significant. Soccer plays the same role as any sport. Soccer is great because Sports foster a sense of community support. A single game can bring an entire community together. Think of what a stadium can do.

If we can successfully implement this project, we can do so much with it, not only seasonal games. Just to name a few, it could foster the community by incorporating projects such as:

1. Soccer Clinics and Coaching Workshops: Organize soccer clinics and coaching workshops for New Mexico youth and coaches. These programs can provide access to quality training, skill development, and coaching expertise, fostering talent and passion for the sport.
2. Soccer Scholarships and Education Support: Offer scholarships and educational support to talented young soccer players. These initiatives can help young athletes pursue their soccer dreams while ensuring they also receive access to quality education.
3. Mental Health and Wellness Programs: Develop soccer-based programs that focus on mental health and wellness for youth. Soccer can be used as a tool to promote physical activity, stress relief, and emotional well-being within the community.
4. Community Soccer Festivals: Organize community soccer festivals that celebrate Indigenous culture and showcase soccer talent. These events can attract local and world wide support and foster a sense of pride and unity within the community.
5. Coaching and Leadership Development: Provide opportunities for individuals to undergo coaching and leadership development programs. Equipping coaches and leaders with the necessary skills can strengthen the sustainability of soccer programs within their communities.

I strongly believe that a new Soccer stadium is the right solution for Albuquerque. New Mexico United soccer has a proven track record of success and has the experience and expertise to execute this project with excellence.

Thank you for considering this proposal. Your support will make a meaningful difference in the lives of our community members.

Sincerely,  
Danette Medina  
5 Applewood Ln nw  
Los Ranchos, New Mexico 87107

[Sent from Yahoo Mail for iPhone](#)

**Bolivar, Silvia A.**

---

**From:** Debbie & Pat Bryan <pdbryan57@gmail.com>  
**Sent:** Monday, March 4, 2024 5:39 PM  
**To:** Bolivar, Silvia A.  
**Subject:** New Mexico United Stadium at Balloon Fiesta Park Appeal

[EXTERNAL] Forward to [phishing@cabq.gov](mailto:phishing@cabq.gov) and delete if an email causes any concern.

Jonathan R. Hollinger, Chair

Environmental Planning Commission

City of Albuquerque

600 Second Street NW

Albuquerque, NM 87102

Mr Chairman:

My name is Pat Bryan. My residence is 812 Harrier Hawk Dr NE.

I was formerly (a very very long time ago) the City Attorney for the City of Albuquerque. As a result, I am a bit more familiar with these types of conflicts than the normal citizen.

Neighborhoods in general don't like any change nearby which creates more traffic or other new impacts on them. That is completely understandable.

I know because I dealt with such conflicts while I was in office and I also represented more than a few neighborhoods in disputes with the City after I left office (when I was in private practice). In addition, I have served as the President of at least 3 separate neighborhoods over the past many years.

So the question almost always comes down to ----- do the benefits of the new development outweigh the possible detrimental impacts on the affected neighborhoods?

I attended the previous EPC hearing (by zoom) and it is my opinion that the public benefits of the proposed stadium far outweigh the somewhat minimal impacts on the affected neighborhoods in this case.

The stadium has been situated in a manner to minimize any impact of noise and lighting on the nearby neighborhoods.

The impact of gameday traffic is far far less than the impact of Balloon Fiesta traffic.

And the public benefits are enormous! Albuquerque gets a privately financed facility that is much needed for Albuquerque residents! With it comes much needed publicly financed improvements to the Ballon Park.

In my humble opinion, the Balloon Park has long been a badly underutilized facility and the addition of this stadium project will be a terrific addition for Albuquerque residents.

Thank you for allowing me to address the EPC on this matter. I urge your support of this important project!

Regards,

Pat Bryan



Jonathan R. Hollinger, Chair  
Environmental Planning Commission  
City of Albuquerque  
600 Second Street NW  
Albuquerque, NM 87102

March 1, 2024

Mr. Hollinger:

My name is Glenn Felty, and I am the founder and CEO of Sunstate Solar Inc. I am in the process of purchasing a building, where I will relocate my company. The location is just north of Balloon Fiesta Park.

As a business owner that will be located near the proposed New Mexico United Stadium, and as a resident of the Northeast Heights, I think the New Mexico United stadium will be a positive game changer for an area of the City that needs an infusion of activity. The area is largely commercial, with a small area that is residential. For the businesses located near Balloon Fiesta Park we need more places to eat, and frankly more places to hang out. The proposed stadium will provide both.

My understanding is that the stadium will be hiring local food and beverage providers, and the intent is that the stadium be open 365 days a year. That means when there aren't games or special events, people can walk around the green areas, run up and down the stairs, have lunch, or hangout and enjoy the views.

As a taxpayer, I think it's important that Balloon Fiesta Park have more activity. The taxpayers are paying to maintain the site for very limited activity currently.

My request is that the EPC once again approve the City and New Mexico United's proposal and let's move forward building the stadium. Thanks in advance for your consideration.

Sincerely,

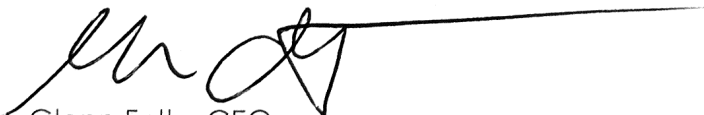
A handwritten signature in black ink, appearing to read 'Glenn Felty', with a long horizontal line extending to the right.

Glenn Felty, CEO  
Sunstate Solar Inc



March 4, 2024

Jonathan R. Hollinger  
Chair, Environmental Planning Commission  
City of Albuquerque  
600 Second Street NW  
Albuquerque, NM 87102

Good morning,

On behalf of the Greater Albuquerque Chamber of Commerce, we are writing again to express our strong support for the amendment to the Balloon Fiesta Park's Master Plan that allows New Mexico United's owners to lease land at the park and build a multimillion-dollar stadium there.

The Chamber believes this project is a win for our city and its residents, as well as for the team. Here are five reasons why:

1. It will improve the park so it can be better utilized year-round for everything from youth sports to special events to recreational opportunities.
2. The actual site of the stadium is a no-fly area for balloonists, the project will add 100 parking spaces, and the team has said matches will not interfere with Balloon Fiesta programming – so the city's signature event comes out ahead.
3. The team has also said it will use a design and materials that buffer light and sound to minimize effects on nearby neighborhoods, as well as utilize the I-25 access road to minimize traffic impacts.
4. In addition to financing the stadium itself, United will use local residents to both build and staff it.
5. The city will get \$35,000 a year, 10% of parking revenues and the use of the stadium and its amenities during fiesta and other events.

The opportunity to have a private entity invest \$30-\$40 million in our city's hardscape – especially in a manner this well-vetted that puts New Mexico jobs, residents and recreation first – does not come along every day. We need to seize it.

This public-private partnership will positively impact our community and economy. The GACC and its Board support the development of a multi-use stadium at Balloon Fiesta Park.

Sincerely,



Peter Lorenz  
Chair, GACC Local Government Affairs  
CEO, Unirac, Inc.



Terri Cole  
President and CEO  
Greater Albuquerque Chamber of Commerce



1309 4th Street SW • El Camino Real • Albuquerque, NM 87102 • 505.842.9003 • Fax 505.764.9664  
www.ahcnm.org

Ernie C’deBaca  
PRESIDENT & CEO

Michelle Hernandez, Esq.  
GENERAL COUNSEL

**EXECUTIVE COMMITTEE**

Paul Mondragon, CHAIR  
Angela Serrano de Rivera,  
CHAIR ELECT  
Erin Gandara, TREASURER  
Robert Dzur, SECRETARY  
Casey Anglada DeRaad,  
VICE-CHAIR  
Frank Garcia, VICE CHAIR  
James Ortiz, VICE CHAIR  
Phil Casaus, PAST CHAIR  
Veronica Martinez, EX OFFICIO

**BOARD OF DIRECTORS**

Nicole Abreu  
Henry L. Andrews  
Kyndra Apodaca  
Amanda Aragon  
Tom Briones  
Ryan Cangiolosi  
Adrian Chavez  
Brian Chavez  
Steven B. Chavez  
Tyler Chavez  
Judy A. Cordova-Romero  
Jim Garcia  
Ruben Garcia  
Ryan Garcia  
Lorenzo Gutierrez  
Matthew Jaramillo  
Chris Johnson  
Richard Luarkie  
Ann Martinez  
Sean Martinez  
Michael Montoya  
Marc Powell  
Harkirat Sareen  
Chris Schroeder  
Janice Torrez  
Ana Trujillo  
Linda Vega

**DIRECTORS EMERITI**

Jon Paul Espinoza  
Sherman McCorkle

**EX-OFFICIOS**

Walt Benson  
Scott Elder  
Mike Kivitz  
Ed Manzanares  
John Martinez  
Olivia Padilla-Jackson  
Loretta P. Martinez, Esq.  
Klarissa J. Peña  
Carlos Romero  
Louie Sanchez  
Col. Michael Power

March 1, 2024

Environmental Planning Commission  
Albuquerque, NM

To Whom it May Concern:

On behalf of the Board of Directors of the Albuquerque Hispano Chamber (Hispano Chamber), we fully support New Mexico United’s proposed stadium at Balloon Fiesta Park.

The proposed soccer stadium is not just about soccer. It’s about raising New Mexico’s profile. It’s about quality of life. It’s about youth sports. It’s about economic development. It’s about bringing in tourism dollars and economic opportunities.

The United Soccer League, which is one step down from Major League Soccer, requires a soccer specific stadium within four years for its professional teams. That time has passed, and if we are serious about support for professional soccer, we need to move forward, quickly. Additionally, there is talk of a woman’s professional soccer team coming to Albuquerque and having a quality stadium enhances our chances.

The New Mexico United Stadium will be paid for privately, will bring people not only for games but for other uses like youth sports, special events, and concerts. The sky is the limit, so to speak.

One of the critical elements when companies look to move to Albuquerque is the quality of life. Having a professional sports team and a stadium that offers multi-use options is exactly the type of asset needed in Albuquerque.

As a bonus, the infrastructure improvements are being paid for by funding received from the State specifically to make improvements at Balloon Fiesta Park. Better parking, permanent restrooms, upgraded electricity and paving are some of the improvements that will enhance the experience for everyone attending any event at Balloon Fiesta Park, including the iconic annual Albuquerque International Balloon Fiesta.

New Mexico United has promised it will not interfere with any Balloon Fiesta programming, and the stadium’s location is under existing power lines and will in no way impact the fly zones.

We see little downside to the new plan, and we hope the City Council will approve the lease so we can all enjoy professional soccer in a quality multi-purpose stadium for New Mexico United.

Ernie C’deBaca  
President & CEO

Jonathan R. Hollinger, Chair  
Environmental Planning Commission  
City of Albuquerque  
600 Second Street NW  
Albuquerque, NM 87102

Dear Mr. Hollinger and Environmental Planning Commission,

Good afternoon. My name is Jake Gutierrez. My wife and I live west of Balloon Fiesta Park in an unincorporated part of Albuquerque off of 2nd Street. I write to you today to voice my very enthusiastic support for the proposed lease agreement which would allow New Mexico United to build a stadium at Balloon Fiesta Park.

While we are not in District 4 and don't have direct representation via City Council, we do live close enough to Balloon Fiesta Park to feel the wonderful shift of energy in our neighborhood annually during that window of time. The proximity to Balloon Fiesta Park and beautiful morning views of the balloons overhead are one of the many reasons we chose to live where we do. While I completely understand concerns about traffic, the volume for a Saturday night United match would be a veritable blip compared to the over 800,000 guests our City admirably funnels into the Fiesta over a 10-day period. With the majority of the 17 or so matches taking place on weekend nights, typical commute times would simply not be affected for the vast majority of residents, but the increased volume of people would be a welcome boon to local businesses along Alameda and on both sides of the park.

I was pleased with the findings from the light and noise reports, and believe the makings of a solid plan are present for Albuquerque to do something creative and bold and allow for a stunning, revenue-generating venue to be built from essentially a pile of dirt in an unused corner of the park. It will provide entertainment for its citizens and grant New Mexico United the opportunity to build a permanent home for themselves, which is critical for their survival.

Our household, our friends and our neighbors are excited at the prospect of this venue and thank you for the opportunity to voice our support.

Sincerely,

Jake Gutierrez



**Bolivar, Silvia A.**

---

**From:** Jake Gutierrez <kickingtv@gmail.com>  
**Sent:** Monday, March 4, 2024 10:14 AM  
**To:** Bolivar, Silvia A.  
**Subject:** Letter of Support for New Mexico United Stadium  
**Attachments:** Proposed Stadium at Balloon Fiesta Park.pdf

[EXTERNAL] Forward to [phishing@cabq.gov](mailto:phishing@cabq.gov) and delete if an email causes any concern.

Please find an attached letter of support for the proposed lease and stadium build for New Mexico United at Balloon Fiesta Park.

Regards,

Jake Gutierrez  
562-208-5332

Jonathan R. Hollinger, Chair  
Environmental Planning Commission  
City of Albuquerque  
600 Second Street NW  
Albuquerque, NM 87102

February 29, 2024

Mr. Hollinger:

My name is Joanie Griffin, and I am a 41-year resident of Albuquerque and a New Mexico United season ticket holder and supporter. I am also the mother of a former AYSO soccer player and know the importance of youth sports in providing a productive and healthy outlet for our young people.

I am in marketing and have been helping organizations produce events for three decades. When New Mexico United first launched in Albuquerque, I was skeptical. We had seen so many professional sports teams come and go – the most recent ones New Mexico Sol (soccer) and the Thunderbirds (basketball). And when I heard they'd be playing at Isotopes Park, I was sure it would never catch on. I did however buy season tickets for opening season and hoped for the best.

All that said – I have been blown away. I haven't seen anything in my 41 years here that comes close to the excitement at New Mexico United Games. The only other event that we have in Albuquerque that draws the passion I see at the games is the Albuquerque International Balloon Fiesta. So, to marry New Mexico United and Balloon Fiesta Park seems like a marriage that will last the test of time.

Balloon Fiesta Park is an amazing location and is grossly underutilized. For the two weeks leading up to the annual Balloon Fiesta, the nine days during the event and the two weeks after, it is a buzz with activity. But other than that, there are a few events a year, and the rest of the time, the taxpayers are paying to maintain a huge park with little activity.

New Mexico United will bring in people for home games, will open up the venue to the Balloon Fiesta for additional VIP seating and viewing, will offer the stadium for other youth sports, for schools to use for graduations, for concerts and other special events. It will also be a home for local vendors including food and beverage, artisans, performers, retailers. As the City continues to grow to the north, it makes sense to use this huge asset for the good of all New Mexicans.

I hope you and the other EPC members will once again vote yes on the stadium at Balloon Fiesta Park.

Thank you for what you are doing for the City.

A handwritten signature in black ink, appearing to read "Joanie Griffin". The signature is fluid and cursive, with a large loop at the end of the last name.

Joanie Griffin, Albuquerque Resident

March 05, 2024

Jonathan R. Hollinger, Chair  
Environmental Planning Commission  
City of Albuquerque  
600 Second Street NW  
Albuquerque, NM 87102

Dear Mr. Hollinger,

My name is Karl Wiese and I am a resident of Rio Rancho. I am writing to you in support of NM United's plan to build a stadium at the Balloon Fiesta Park. The benefits to our community and State far outnumber the exaggerated negative impacts being voiced by some area residents.

Prior to 2019, I knew little about the sport of soccer and was not an avid fan. But after attending a couple of NM United matches, I was hooked. I was awed not only by the excitement of the game itself, but by the enthusiasm of the fans and how the game brought thousands of NM citizens, from all walks of life and cultural backgrounds, together for a common good.

The joy on the faces of hundreds of children waiting in line at the end of a match for an opportunity to meet players and get an autograph - while proudly wearing their jerseys or t-shirts supporting the team or their favorite player - is remarkable. No other event or sport in our State has ever created that level of enthusiasm in our youth. Soccer is a sport that almost any child can play, and even those who are unable to play can benefit from being a fan and feeling involved.

NM United soccer and the positive social impact that their Somos Unidos Foundation has made in New Mexico is beyond commendable. Shortly after attending those first matches, my wife and I joined The Curse, a NM United fan club devoted to supporting the team and their philosophy of promoting diversity, equity and inclusion. I am a conservative by nature, but being a member of the club has given me an opportunity to meet and really know people from the Black, LGBTQ+ and other communities that I would not have had otherwise. Many of them have become friends and have changed my perspective about acceptance of others.

NM United Soccer (and New Mexico) needs this stadium to remain in our State and continue to benefit its citizens for years to come. We cannot afford to lose them.

As a former Rio Rancho P&Z commissioner, I often considered comments from neighborhood associations and individuals who opposed projects or developments designed to improve or enhance quality of life. But I also learned that their opposition was too often based on their individual preferences or agendas, and not on the benefits and quality of life for the entire community.

Thank you,



161 High Ridge Trail SE, Rio Rancho, NM 87124  
(505) 934-5275

**From:** [Michael Lewis](#)  
**To:** [Bolivar, Silvia A.](#)  
**Subject:** NM United stadium  
**Date:** Monday, April 1, 2024 4:02:49 PM

---

**[EXTERNAL]** Forward to [phishing@cabq.gov](mailto:phishing@cabq.gov) and delete if an email causes any concern.

Jonathan R. Hollinger, Chair

Environmental Planning Commission

City of Albuquerque

Dear Mr. Hollinger,

I am in favor of building a stadium for our USL soccer team - New Mexico United - at Balloon Fiesta Park. I am the marketing manager for M'tucci's Restaurants, one of the largest independently owned restaurant groups in the state. We have been partnering with New Mexico United for the last three seasons, and the partnership has helped us expand our brand awareness throughout the Metro area.

As I'm sure you know, New Mexico United has taken New Mexico by storm, with attendance at games averaging 10,000, which rivals Isotopes. If the stadium was bigger and built specifically for soccer, they would probably match Lobo basketball attendance.

New Mexico United consistently is one of the top teams in the USL in terms of attendance and sponsorship. If we want to keep them as part of our community, they are required by the league to have their own stadium.

Our elected officials are working hard to diversify our economy, reduce our dependence on oil and gas revenue and bring new businesses and good jobs to the State. One of the key decision factors when an organization considers a location is quality of life. Other than the Isotopes, New Mexico United is our only large and viable professional sports team. And soccer is the fastest growing professional sport in the country. Economic development organizations tout New Mexico United and use it as a tool to recruit business. I lived in Denver in the 90s and saw the positive economic impact that the Colorado Rockies had on Denver in general and the lower downtown neighborhood in particular. We can make that happen in Albuquerque, too.

Balloon Fiesta Park is one of the jewels of the City and it is grossly underutilized. In addition to the nine days of the iconic Albuquerque International Balloon Fiesta, the park is only used for a handful of special events a year. Having the stadium at Balloon Fiesta Park will activate the park 365 days a year.

The team has said the stadium will be open always - which means people can run up and down the bleachers, hang out and admire the spectacular views, or enjoy a cup of coffee, lunch or happy hour at one of the local venues that will call the stadium location home.

Please consider the positive impact of a stadium in this part of the city and approve this project.

Sincerely,  
Michael S. Lewis

\* \* \* \* \*

Michael S. Lewis  
Marketing Manager  
M'tucci's Restaurants LLC  
<http://www.mtuccis.com/>

505-357-7118

<https://www.michaelslewis.com>



Jonathan R. Hollinger, Chair  
Environmental Planning Commission  
City of Albuquerque  
600 2nd Street NW  
Albuquerque, NM 87102  
**Re: New Mexico United Stadium**

March 4, 2024

To whom it may concern,

I hope this letter finds you in good health and high spirits. I am writing to you today as a concerned and passionate member of our community who firmly believes in the potential for positive change and growth that a soccer stadium can bring to our city and state. The construction of a soccer stadium promises to enhance our local and state economic development, as well as provide invaluable opportunities for our children and secure a brighter future for our beloved home.

Soccer, as a sport, has a universal appeal that transcends age, gender, and cultural boundaries. It brings people together, fosters a sense of community, and promotes physical fitness and well-being. A soccer stadium in our city would serve as a gathering place for residents of all ages and backgrounds, nurturing a sense of unity and shared identity.

The economic benefits of a soccer stadium are significant. Not only will the construction of the stadium create jobs and stimulate economic activity, but it will also attract visitors from near and far. These visitors will patronize local businesses, dine at our restaurants, and stay in our hotels, which will lead to increased revenue and tax income for the city and state. Additionally, the presence of a stadium will be a source of civic pride and will help put our city on the map as a vibrant and exciting place to live and visit.

When we consider the well-being of our children, the benefits become even more apparent. A soccer stadium will offer our youth a safe and engaging environment to nurture their passion for the sport. It will encourage physical activity, teamwork, and discipline. A soccer stadium can also serve as a venue for educational and community events, enriching the lives of our children and strengthening their connection to our city.

The proposed location for the stadium, at Balloon Fiesta Park, is ingenious. This location is an icon of our state and something that is recognized globally! I would like to reiterate my fellow stadium supporter's remarks about the proposed stadium location:

*"Balloon Fiesta Park is a jewel in the city – but it is underutilized. It sits dormant for about 300 days a year. The New Mexico United Stadium will activate the area – bringing people not only for games but for other uses like youth sports, special events, concerts, exercising, and enjoying the views."*

While NO location will be perfect or make everyone in the community happy, we must take into consideration the long term benefits to our city and especially the youth of our city, over the conveniences of local homeowners. In the end, the inconveniences we ALL face as part of the progress will be outweighed by the benefits.

The decisions we make today will shape the future of our city and its residents, especially the younger generation. By supporting the construction of a soccer stadium, we will be contributing to the growth, vibrancy, and economic prosperity of our city and state, while also providing a place where our children can dream and excel.

Thank you for your time and dedication to our community.

Sincerely,  
Randi Guthrie

**Lifelong resident, mother, and business owner in Albuquerque!**

PO Box 67062  
Albuquerque, NM 87193  
[homesbyrandi@gmail.com](mailto:homesbyrandi@gmail.com)  
505-585-3854

**Bolivar, Silvia A.**

---

**From:** Homes by Randi <homesbyrandi@gmail.com>  
**Sent:** Monday, March 4, 2024 10:39 AM  
**To:** Bolivar, Silvia A.  
**Subject:** Stadium support letter  
**Attachments:** Stadium support letter.pdf

[EXTERNAL] Forward to [phishing@cabq.gov](mailto:phishing@cabq.gov) and delete if an email causes any concern.

Hello Silvia,  
Here is my letter, for the EPC, in support of the NM United Stadium. Have a wonderful Monday.

Randi

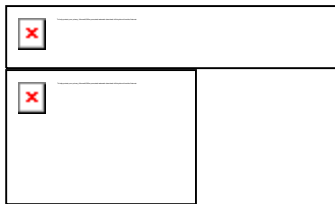

**RANDI GUTHRIE**  
Founder|Associate Broker

**505-585-3854**

[www.HomesByRandi.info](http://www.HomesByRandi.info)

[HomesByRandi@gmail.com](mailto:HomesByRandi@gmail.com)

[9674 Eagle Ranch Rd. #3, ABQ, NM 87114](#)

License #53176



---

IMPORTANT: The contents of this email and any attachments are confidential. They are intended for the named recipient(s) only. If you have received this email by mistake, please notify the sender immediately and do not disclose the contents to anyone or make copies thereof.



**Bolivar, Silvia A.**

---

**From:** ROB DURHAM <durhamabq@comcast.net>  
**Sent:** Monday, March 4, 2024 11:20 AM  
**To:** Bolivar, Silvia A.  
**Subject:** Proposed United NM Stadium

[EXTERNAL] Forward to [phishing@cabq.gov](mailto:phishing@cabq.gov) and delete if an email causes any concern.

Mr. Hollinger:

My name is Robert Durham, and I am an Albuquerque resident as well as a season ticket holder for New Mexico United. Also, my wife's company is a sponsor of the Albuquerque International Balloon Fiesta. As an attendee of both – I can't think of a better place for New Mexico United's stadium to be than the Balloon Fiesta Park.

Balloon Fiesta Park is a jewel of the city and is grossly underutilized. While there are some neighbors within the vicinity, it is mostly in an industrial/business area. I do understand that some of the neighbors are against the stadium, but in my opinion, they choose to live by the Balloon Fiesta Park, so they already have traffic and noise to deal with not only when the Albuquerque Balloon Fiesta is happening, but throughout the year while there are other events happening there.

Since I commented at the last EPC hearing, I've been included in all the emails from the EPC. I've read all the sound and light studies, and it seems like the stadium will not negatively impact the neighbors, as most of them are located far enough away from the stadium for those not to be an issue.

We are a growing city, with growing needs of the population. One need is to have more spaces for special events. The Balloon Fiesta Park location for a stadium will provide a venue for more youth sports. And potentially for a professional women's soccer team, as well as concerts and other events.

I am writing to urge you and the rest of the EPC members to once again approve the City and New Mexico United's request to update the Balloon Fiesta Park Master Plan to allow for a multi-use stadium.

Thank you for consideration.

Robert Durham  
Albuquerque Resident

**Bolivar, Silvia A.**

---

**From:** Robert Romero <rgoalierob@icloud.com>  
**Sent:** Monday, March 4, 2024 9:20 AM  
**To:** Bolivar, Silvia A.  
**Subject:** Please Approve The Stadium Plan

[EXTERNAL] Forward to phishing@cabq.gov and delete if an email causes any concern.

Dear Mr. Jonathan R. Hollinger,  
Chair  
Environmental Planning Commission  
City of Albuquerque  
600 Second Street NW  
Albuquerque, NM 87102

Please approve the proposed site at Balloon Fiesta Park. It's a win-win as the the team will provide much needed upgrades to the park and it will make the park more useful year round.  
The impact to the nearby neighborhoods should be minimal as the crowds that attend the matches are vastly smaller than the actual balloon fiesta crowds. The neighborhoods near Isotopes Park have had minimal impact after United matches.  
Thank you for your help in making our city better and more livable.  
Sincerely,

Robert Romero, PT



Jonathan R. Hollinger, Chair  
Environmental Planning Commission  
City of Albuquerque  
600 Second Street NW  
Albuquerque, NM 87102

March 6, 2024

I am writing in today as President/CEO of United Way of North Central New Mexico and an Albuquerque resident. I have lived here for four years and am raising my family here. Our favorite things to do in Albuquerque are attending both New Mexico United games and the Albuquerque International Balloon Fiesta. The potential of having these two iconic brands living side by side at the Balloon Fiesta Park is a very exciting prospect.

New Mexico United has taken our city by storm. The excitement at the games and the diversity of the fans is palpable. And the organization has been philanthropic, supporting all sorts of organizations from youth soccer to tribal organizations, to non-profits, to LGBTQ+. The team leadership personifies what makes our city and state so great.

I know you are considering whether to approve the City of Albuquerque and the New Mexico United's application to build a stadium at Balloon Fiesta Park. The EPC approved it before, and I encourage you to do so again.

The team needs to have a permanent home, by USL rules, and the lease at Isotopes Park expires in 2026. The Albuquerque International Balloon Fiesta Board of Directors doesn't oppose the stadium since it will have no negative impact on either the fiesta or hot air ballooning in Albuquerque. And the best part will be activating Balloon Fiesta Park year-round for a variety of activities including youth soccer, special events and having the stadium open for people to enjoy 365 days a year.

Thank you for taking up the matter again.

Sincerely,



Rodney Prunty, President/CEO  
United Way of North Central New Mexico

**Bolivar, Silvia A.**

---

**From:** Terrye Mola <terryemola@gmail.com>  
**Sent:** Friday, March 1, 2024 6:16 PM  
**To:** Bolivar, Silvia A.  
**Subject:** New Mexico United

[EXTERNAL] Forward to [phishing@cabq.gov](mailto:phishing@cabq.gov) and delete if an email causes any concern.

Jonathan R. Hollinger,  
Chair Environmental Planning Commission  
City of Albuquerque  
600 Second Street NW  
Albuquerque, NM 87102

March 1, 2024

My name is Terrye Mola. I'm an Albuquerque resident, a retired soccer mom and a volunteer with the SOMOS Unidos Foundation, as well as a New Mexico United fan. I lived in Albuquerque for about 25 years, left for six years and moved back in late 2020. I was pleasantly surprised to see some of the changes to the Duke City while I was gone, and the biggest one was New Mexico United. I went to my first game in 2023 and was hooked. I immediately signed up to volunteer with the foundation. I am beyond impressed with the organization and the good they do throughout the state.

I'm hoping the team finds a permanent home, and I think the best location is Balloon Fiesta Park. I was an avid balloon enthusiast when I lived here before, and spent more than a decade on a chase crew. Since the stadium will be built under the power lines, there is no issue with the stadium impacting the iconic annual balloon fiesta.

I've attended many of the special events that are held at the Balloon Fiesta Park, and I believe we need more. I understand that the plan with the New Mexico United stadium is to have it be multi-purpose, and available for other uses, including youth soccer, which I am passionate about.

I believe the proposed New Mexico United stadium is a win win win for everyone. It's obviously a win for the team, that will have a permanent home. It's a win for the balloon fiesta because they can use the venue for additional parking and viewing. And it's a win for the citizens of Albuquerque, because we'll have another venue for entertainment.

Sincerely,

Terrye Mola

## Bolivar, Silvia A.

---

**From:** thomas.cooley@comcast.net  
**Sent:** Sunday, March 3, 2024 8:02 AM  
**To:** Bolivar, Silvia A.  
**Subject:** New Mexico United Stadium at Balloon Fiesta Park

[EXTERNAL] Forward to [phishing@cabq.gov](mailto:phishing@cabq.gov) and delete if an email causes any concern.

To: Jonathan R. Hollinger, Chair,  
Environmental Planning Commission  
City of Albuquerque  
600 Second Street NW  
Albuquerque, NM 87102

Mr. Hollinger:

I am writing to again express my strong support for the New Mexico United Stadium at Balloon Fiesta Park. I attended virtually and spoke on behalf of this important project to our community and to the City of Albuquerque, in particular. To reiterate some of my previous points and to ensure you and your commission understand the importance of this to the vast majority of the citizens of Albuquerque, I want to highlight a few items for you, which are most important to me as a tax-paying citizen of our fine city.

- New Mexico and the City of Albuquerque have very few professional sports teams for sport spectators to enjoy compared to other similar sized cities, making Albuquerque less attractive as a place to live and work.
- As a consultant for ~20+ companies across the United States, I encourage companies to consider Albuquerque as a place to locate or expand their operations but the quality of life, including availability of entertainment such as stadiums and professional teams, is always a question. What message are we as a city sending if we effectively kill a thriving and broadly supported professional sports team? That path is a downward spiral for the city.
- The residents near the site were never guaranteed a “no-new-development” area. In fact, they should have known and accepted that BECAUSE the area is largely undeveloped in a growing metropolitan region, it WILL BE developed at some point in the future. Their complaints are very selfish and do not consider the importance of this to the city at large. Will our city stop growing and improving because of a few people who complain that the noise will disturb their horses and other domestic animals? The absurdity of their selfish arguments do not deserve further attention.
- As a father who supported my children through soccer by coaching and refereeing, I testify to the positive impact of having role models in the sport to aspire to and the positive impact of participating in sport activities. There are many studies that support these connections for children. If you choose to not recognize these connections to our youth and to not support the expansion and growth in an area that is well placed for the stadium, the negative message and abandonment of our community would be heard loud and clear by adults and youth alike.

I urge you to make the right decision and support the New Mexico United Stadium at Balloon Fiesta Park. To do otherwise is backward-thinking, unthinkable and shameful. Please feel free to reach out to me if you have any questions or concerns that you would like to address with me.

Tom

Thomas Cooley, Ph.D  
P.O. Box 35754  
Albuquerque, NM 87176-5754  
Mobile: [505-385-6110](tel:505-385-6110)

The unauthorized disclosure or interception of e-mail is a federal crime, See 28 U.S.C. Sec. 2511(4). This e-mail is intended only for the use of those to whom it is addressed and may contain information which is privileged, confidential and exempt from disclosure under the law. If you have received this e-mail in error, do not distribute or copy it. Return it immediately to the sender with attachments, if any, and notify the sender by telephone.

Tim Spears  
[tspears@ultramain.com](mailto:tspears@ultramain.com)  
(505)414-7900  
Tuesday, March 5, 2024

Jonathan R Hollinger, Chair  
Environmental Planning Commission  
City of Albuquerque  
600 Second Street NW  
Albuquerque, 87102

Dear Jonathan,

I have been a resident of Albuquerque for the past 24 years. Over that time, I have lived in various parts of the city, and I currently own a home to the East of the Balloon Fiesta Park (across the I25).

Since I moved to Albuquerque, from London, my wife and I have raised two children here, both of whom have moved on, one to the East coast and one to the West coast. Both are well-qualified with degrees from leading universities, but neither would consider coming back to live in Albuquerque. This is largely because Albuquerque lacks the appeal of many other cities, and a contributing factor to that is a lack of good professional sports teams and facilities.

I work for a company that hires many young software engineers, and it's difficult to find local talent and even more difficult to persuade young adults from other cities to move to Albuquerque to take up employment.

It doesn't need to be this way, and a new soccer stadium alone will not solve these issues. It is, however, a step in the right direction.

Of course there will be some aspects of the new stadium that will be inconvenient for me, and I have a direct line-of-sight to the planed location from my house, so I will certainly get some noise pollution from it. However these are, in my opinion as a local homeowner, acceptable costs for the significant benefits this will bring with it.

I wholeheartedly support the development of this stadium at the Balloon Fiesta Park, and ask that you take my support into account to help offset the vocal minority in our community would rather keep Albuquerque in the middle ages.

Thank you and best regards,  
Tim Spears

NEIGHBORHOOD CONCERNS

LETTERS OF OPPOSITION



**From:** [Angela Stell](#)  
**To:** [Bolivar, Silvia A.](#); [Planning EPC](#)  
**Subject:** public comment re proposed United stadium at BFP  
**Date:** Saturday, March 9, 2024 6:07:05 PM

---

**[EXTERNAL]** Forward to [phishing@cabq.gov](mailto:phishing@cabq.gov) and delete if an email causes any concern.

Hello. I am writing to you today as a North Valley resident of 9 years. I also run an all-volunteer non profit dog rescue, founded in 2010. We serve Bernalillo County & the state, we are also founding members of the Bernalillo County Animal Cruelty Task Force, through BCSO. Our headquarters & kennels are permitted & licensed through Bernalillo County Animal Services & we are located near el Pueblo rd NW & the NW Edith corridor, in the North Valley...very close to Balloon Fiesta Park. It is in these kennels that we provide medical & behavioral rehabilitation to victims of some of the most severe cases of animal cruelty. This is their refuge, their sanctuary, their safe place until they are able to be adopted to proper homes. During Balloon Fiesta, as you can imagine, it is a challenge to "keep the peace" on our property for the dogs. But Balloon Fiesta is organized very well, with traffic passes, a schedule of events & other accommodations made in consideration for the local residents. &....it is one week out of the year. We are able to make the necessary adjustments to daily routines, etc in order to keep our dogs healthy & safe during mass accessions & firework displays (although it would be GREAT if fireworks were replaced with drones! Just for the record...). With the proposed stadium, this would be absolutely impossible & just not feasible to sustain. If this is approved, I think NMDOG would have to seriously consider relocation of our headquarters...as we would never willingly choose to be so close to a sports stadium & all of the disadvantages that come with that. It would truly be devastating to our overall operation.

Not only would the proposed stadium greatly diminish our quality of life & that (+ the safety) of our dogs....but it would directly affect every local citizen & their animals in this valuable community, in a very negative way. The noise pollution (including, but not limited to, firework displays) that comes with a sports stadium are not something that should be burdened upon a long standing, peaceful & generational, agricultural neighborhood. The effect this noise pollution would have on the poultry, horses, llamas, dogs, cats, goats, sheep, sandhill cranes, our wild bird population, the wild animals such as our coyotes, raccoons, squirrels, etc has the potential to cause injuries & even death at an alarming rate. (Im happy to provide proven numbers & statistics for you upon request). There are MANY documented cases of injury & death of domesticated & wild animals as a result of firework trauma. Not to mention disruptive (at best) to regular residents & traumatizing (at worst) to our military veterans. The light pollution created by an unsealed stadium would wreak havoc on the migratory path of many of our beloved birds. I cannot speak for Animal Services, but I would think having this level of disruption in their service area (both County & AWD) would greatly increase calls of service for animals running at large, hit by cars, injury, etc, as a result of increased traffic, noise pollution & consistent fireworks. They already struggle to maintain current calls for service due to staffing issues.

I strongly urge you to take into consideration the quality of life that so many (humans & animals) hold sacred & have worked extremely hard (over generations) to create here in the North Valley - & to put all profit & financial gain considerations on the backburner. Because what truly matters the most is safety, quality of life for ALL citizens (human AND animals) &

the integrity of our communities. With a stadium such as the one proposed, there will also be an increase in gathering of the unhoused population, as well as crime to our neighborhood. Thank you so much for your time & consideration.

for the *LOVE* of *DOG*...

Angela Stell

Founder/Director, NMDOG

[NACA](#) certified



[NMDOG](#) is an in-the-trenches dog rescue serving the chained, the abused & the Forgotten Dogs of NM [Follow us on Facebook](#) to see our work on the frontlines #UNchained

**With my eyes, they will be seen. With my voice, they will be heard. With my hands, they will know comfort. With my ACTION, they will be FREE!!!**

CONFIDENTIALITY NOTICE: This email is intended only for the person or entity to which it is addressed and may contain information that is privileged, confidential or otherwise protected from disclosure under applicable law. Any use, disclosure, distribution, or copying of this email or the information contained herein by anyone other than the intended recipient is prohibited and may be a violation of state and/or Federal privacy laws. If you have received this email in error, please delete any copies of it from your computer.

**From:** [ANTHONY LOVATO](#)  
**To:** [Bolivar, Silvia A.](#); [Planning EPC](#)  
**Subject:** March 21, 2024 - EPC Comments  
**Date:** Monday, March 11, 2024 8:59:38 AM

---

**[EXTERNAL]** Forward to [phishing@cabq.gov](mailto:phishing@cabq.gov) and delete if an email causes any concern.

To whom it may concern,

Here are our concerns with the Multi-Use Stadium that that is being looked at to go into the Albuquerque Balloon Fiesta in the upcoming future. We are both totally **opposed** to this due to the reasons below, that we have experienced personally living in the Wildflower Neighborhood for over 30 years.

**Traffic:**

There has been no traffic study of the effects of this stadium on **surrounding** neighborhoods. Although United has a plan that it says will take pressure off the Wildflower neighborhood, there is nothing in any document that states what traffic measures the team will be required to carry out, what penalties the team will face for falling short of those requirements and what recourse neighbors will have if traffic spills over into their streets.

Another issue that has not been addressed is the phenomenon neighbors living around the park routinely experience during Balloon Fiesta, Freedom 4<sup>th</sup> and other festivals where parking fees are required: to avoid paying to park, people park on adjoining streets and **trespass through private property** to walk to the event. On Watercross, for example, this is ongoing even though the road is closed to outside traffic and access passes are supposed to help limit neighborhood access control anybody can get into the neighborhood. No policing or traffic control has occurred in the neighborhood and ingress and egress to it. Racing on surrounding streets on weekend nights and some weeknights is also an issue. This has been brought up yet have never been fully addressed since it is still occurring.

**Noise and light:**

We know that an open-air stadium will cause noise and light pollution. The team claims to have done a sound study. They haven't. There's literally no way for the team to accurately assess the impact the stadium will have on neighborhoods in terms of noise. The team's architect said at a meeting with neighbors in March that sound on the field could reach 90 decibels, not sure what amplified levels could reach. He also promised to do another sound study that will actually measure sound from the proposed stadium area to neighboring houses. That study will not happen until after the EPC has already decided this matter. We should be able to know the results *before* a decision is made. The team also claims to be designing the stadium with expensive lights that will not impact neighbors. This is another example of the team saying something but not putting it in writing with any specifics and there being no mechanism to hold the team to its promise.

The city's own Balloon Fiesta Park Master Plan states: "The concept of Balloon Fiesta Park being a 'family park' should be recognized when selecting special events and activities to occur in the Park with regard to noise. The concern for mitigating noise impacts has emerged as a powerful determinant for locating activities in the Park, and precludes the use of the Park for carnivals, fair midways, and similar commercial

events.

The city's own noise ordinance states: "B) A substantial body of scientific research has shown that **exposure to excessive sound and vibration is a serious hazard to the public health, welfare, safety and quality of life.** It is the express intent of the City Council to control the level of excessive sound as noise in a manner that promotes the use, value and enjoyment of property, conduct of business, sleep and repose and an environment free from unnecessary and excessive sound."

**Safety and Security:**

We currently experience 9 days of increased automobile and foot traffic, increased noise and lighting during balloon fiesta. The events to be held at the new stadium could possibly increase by 50 weeks of activity. This has increased safety and security concerns for ourselves and our neighbors. With the increase in automobile and foot traffic comes an increase to crime (theft, speeding, etc.), accidents, trash discarding, especially during events that allow liquor sales at the stadium. The street we live on has become a short cut to get from Jefferson to San Mateo and vice-versa. We have an age-diverse neighborhood ranging from seniors, middle-aged, and younger residents, some having small children thru high school aged. We enjoy the **peace** and **tranquility** that living in this neighborhood has provided and would like to keep it that way.

Best Regards

Anthony & Sandra Lovato

4910 Watercress Dr. NE

**From:** [BARI Harvey](#)  
**To:** [Bolivar, Silvia A.](#)  
**Subject:** Opposition of The United Stadium at Balloon Fiesta Park  
**Date:** Monday, March 11, 2024 12:41:57 AM  
**Importance:** High

---

[EXTERNAL] Forward to [phishing@cabq.gov](mailto:phishing@cabq.gov) and delete if an email causes any concern.

Ms. Bolivar,

***My husband and I are formally requesting that the EPC hearing be rescheduled from the March 2024 docket to the April 2024 docket to allow for proper preparation from the neighborhoods affected by the building of The United Soccer Stadium at Balloon Fiesta Park.***

We are not opposed to soccer, however, the way this is all being done and where it is intended to be built is not a logical choice as many neighborhoods in the surrounding area will be affected in many ways. All of this has been done very **sneaky, underhanded and very FAST** and the surrounding areas have not been contacted in a very sufficient manner. This was voted **AGAINST** by a citywide vote, yet it is still underway. A lot of people have thought this was not happening because of that vote, hence, done sneaky and now the governor is being underhanded with taxpayers monies!

We have lived in the Wildflower neighborhood since 1989 and the people that cut through this neighborhood has steadily gotten worse as time goes on. We have almost had kids out playing and adults just walking through the neighborhood hit by cars that cut through from San Mateo to Jefferson for one reason or another and they do not stop at the stop sign and just fly through. I saw it during balloon fiesta when a balloon landed in my yard and there were many people around to watch the balloon that landed. The city doesn't feel the need for speed bumps or anything to prevent cutting through the Wildflower neighborhood because they have never been here when there are any events and it would probably not help anyway because they are only considering certain spots and not the whole neighborhood since the people from the Soccer group has spoke to them to give themselves "brownie points" to show how they are working with the neighborhoods, finally!! The only way to fix this problem is to eliminate any additional events like concerts and The Soccer Stadium itself!!! That is another thing, The United is supposed to have 10 additional events as they told us at the first meeting they had with us after they were concerned about us shutting them down but nothing is being updated in the lease. We were told this at a meeting with the neighborhood and this occurred because somehow they found out about a previous meeting the neighborhoods were having and they intruded in that instead of properly contacting to join!

To the west of the Stadium you have farm animals and wildlife around the diversion channel that will be affected by the noise & lights and disruption of our International Balloon Fiesta that will bring more money to the city/state than the United Soccer Team will as the way the lease is written they are getting a heck of a deal. In the Wildflower area the noise from screaming fans, horns and tailgating along with the lights will hinder our neighborhood. We were told there would be no tailgating, etc., well the nice little thing channel 7 had on the news for The United Soccer team had a fan saying how for 5-7 minutes they will be screaming, blowing horns & drumming non-stop! The traffic is another thing, they said they will divert traffic to Tramway but



when there is any kind of wreck on the freeway or Paseo del Norte, traffic is backed up for miles. There was a wreck last week and from the Alameda exit to my house in the Wildflower neighborhood took me 25 minutes which normally takes 5, maybe 10 if the light is red and this is at 4:15pm, imagine at 5:30 or 6 when you have people coming for a game in this area. Alameda going to the west side barely moves as it is at this time of night.

It appears that the money from this will just line some certain people's pockets! I can list them, but at this point it would be inappropriate to do. The United Soccer group & "fans" get a lot of positive media attention but anyone that might want to talk about it not being in this area gets cut off. I was at a City Council meeting after all of the fans for The United spoke about how this has "saved" their lives and used more than the allotted 2 minutes! I got cut off because I asked if there had been any impact studies on traffic through the neighborhood and I was told I had to only talk about what was on the docket and only had 2 minutes, well this was on the docket but not what they wanted to hear. What happened to freedom of speech for everyone??? Also, the City Councilors postponed it 90 days but surprisingly after we all left because they went on their "lunch break", they re-voted when we were not present and changed it to 30 days. More underhanded things to make it go the city's way because I am pretty sure our Mayor made sure his people were still going to be there to vote. I am not usually this person but I am really tired of the games that are being played with people's monies that are struggling to make it day to day because of the way our city runs things now! Also, how the families can't enjoy their quiet neighborhoods.

**Again, please consider rescheduling the EPC hearing from March to April to allow sufficient time for all those involved.** This is to have all studies completed and lease properly updated and all notifications sent out in the correct timely manner. Wildflower is not being contacted properly as it has been told numerous times that our president is in a care facility and the person he "appointed" does not notify anyone because he is for this happening because it will benefit his pockets due to an Airbnb he has! I, Bari Harvey, have been in the loop because of the other neighborhood associations contacting me for area meetings and I contact our neighbors.

Sincerely,

Bari & Russ Harvey  
Wildflower Neighborhood

## Bolivar, Silvia A.

---

**From:** BARI Harvey <boyznbari@msn.com>  
**Sent:** Thursday, February 29, 2024 12:59 PM  
**To:** anvanews@aol.com  
**Cc:** t-marie-v@hotmail.com; fishman@consensusplanning.com; hdhauser@comcast.net; phcrumpsf@gmail.com; Johnson@consensusplanning.com; brookemjordy@gmail.com; staylor@taylortowers.com; alamedamontoya@gmail.com; christinebnvdz@aol.com; emyers\_11@yahoo.com; stemax1@aol.com; grumpyeh46@comcast.net; szuschlag58@gmail.com; Bolivar, Silvia A.; wbenson@bernco.gov; peggynorton@yahoo.com; mgriffee@noreste.org; sec.dist4@gmail.com; edueweke@juno.com; kbbh@hotmail.com; ggarcia103@comcast.net; gypsy.rose46@gmail.com; haederle@yahoo.com  
**Subject:** Re: Meeting Notification - Balloon Fiesta Park / NM United Stadium

[EXTERNAL] Forward to [phishing@cabq.gov](mailto:phishing@cabq.gov) and delete if an email causes any concern.

I am responding on behalf of Wildflower Neighborhood Association. The names you have for contacts don't have any issues with this so no one gets notified but many of the neighbors in this area do. I had a couple days last time to get notifications to the neighborhood and didn't even reach them all! Please consider people who work and do things during the week after work as well. Let's do this right or better yet, not at all. If this was wanted then there wouldn't be so much push back especially since it wasn't done right in the first place it has left even a worse taste about this whole thing!!! The time limits as mentioned are another thing! Any person to do with United was never cut off and could say what they want. The people against this were cut off and had to stay within the guidelines set! So it is obvious there is a push for this and to hurry it along makes it even worse.

Sincerely,  
Bari Harvey  
Wildflower resident since 1989!

On Feb 29, 2024, at 12:04 PM, anvanews@aol.com wrote:

Good afternoon,

I am in 100% Agreement with Pat Houser and Tina Villegas who stated the proposed meeting is rushed and does not allow for adequate notification or preparation. The points raised below are valid and should be considered.

The meeting should be held when there is adequate time for all to respond and make plans for a productive meeting. Set the meeting at least week into the future as was suggested by others.

We were only able to access the sent emails this morning - 2-29-2024. ANVA was never asked about what times would work best for the a meeting.

The arrogant and presumptuous announcements of the meeting times set by Consensus Planning is wrong. Setting the meeting for Monday is as we say in the north valley: complete and utter BS!

This illustrates why people were left out of the notification processes and why people have so many questions, fears and anger about the proposal. It is very apparent the agents for the City and United Soccer don't care about any type of real communication or collaboration with the community. This is wrong and the City of Albuquerque, United Soccer and their paid agents should be ashamed of their attitudes and arrogant actions.

Steve Wentworth  
Pres. Alameda North Valley Association

In a message dated 2/29/2024 8:04:47 AM Mountain Standard Time, t-marie-v@hotmail.com writes:

Good Morning,

I agree with Mr. Hauser that the notification of this meeting feels rushed and does not allow enough time for persons to be notified adequately as per the IDO. Also, since this is the only meeting that is scheduled if persons are unable to attend due to the short notice will another be scheduled prior to the EPC hearing on 3/21? I feel it is necessary to inform as many affected property owners so they have a chance to understand the full effect a new stadium will have on their neighborhood, be able to participate, and be able to give their feedback as allowed by this process.

I also think the meeting should allow for participation in person, via electronic, and by telephone because some may not have the means to attend electronically or by phone.

I respectfully request you consider Mr. Hauser's request.

Thank you.

**-Tina M. Villegas**  
**10212 Edith Blvd NE**  
**Albuquerque, NM 87113**  
**505-269-4652**

---

**From:** Jackie Fishman <fishman@consensusplanning.com>  
**Sent:** Thursday, February 29, 2024 5:20 AM  
**To:** Pat Hauser <hdhauser@comcast.net>; [mgriffie@noreste.org](mailto:mgriffie@noreste.org) <mgriffie@noreste.org>; [sec.dist4@gmail.com](mailto:sec.dist4@gmail.com) <sec.dist4@gmail.com>; [edueweke@juno.com](mailto:edueweke@juno.com) <edueweke@juno.com>; [kbbh@hotmail.com](mailto:kbbh@hotmail.com) <kbbh@hotmail.com>; [ggarcia103@comcast.net](mailto:ggarcia103@comcast.net) <ggarcia103@comcast.net>; 'Maggie Rose' <gypsy.rose46@gmail.com>; [anvanews@aol.com](mailto:anvanews@aol.com) <anvanews@aol.com>; 'Michael Haederle' <haederle@yahoo.com>  
**Cc:** Charlene Johnson <Johnson@consensusplanning.com>; [brookemjordy@gmail.com](mailto:brookemjordy@gmail.com) <brookemjordy@gmail.com>; [staylor@taylortowers.com](mailto:staylor@taylortowers.com) <staylor@taylortowers.com>; [alamedamontoya@gmail.com](mailto:alamedamontoya@gmail.com) <alamedamontoya@gmail.com>; [christinebnvdz@aol.com](mailto:christinebnvdz@aol.com) <christinebnvdz@aol.com>; 'Tina Villegas' <t-marie-v@hotmail.com>; [emyers\\_11@yahoo.com](mailto:emyers_11@yahoo.com) <emyers\_11@yahoo.com>; [stemax1@aol.com](mailto:stemax1@aol.com) <stemax1@aol.com>; [grumpyeh46@comcast.net](mailto:grumpyeh46@comcast.net) <grumpyeh46@comcast.net>; 'BARI Harvey' <boyznbari@msn.com>; 'Sandy Z' <szus Schlag58@gmail.com>; 'Bolivar, Silvia A.' <sabolivar@cabq.gov>; [wbenson@bernco.gov](mailto:wbenson@bernco.gov) <wbenson@bernco.gov>; Peggy Norton <peggynorton@yahoo.com>; Steve Wentworth <anvanews@aol.com>  
**Subject:** Re: Meeting Notification - Balloon Fiesta Park / NM United Stadium

Pat - please call me at 8:00 at my office number to discuss. As the primary appellant, I originally called you specifically on Tuesday and then got a call back from Brooke yesterday, who she said you asked to call me back. She and I discussed the date and we agreed Monday was acceptable.

Talk to you soon.

Jackie Fishman, AICP  
Principal

---

**From:** Pat Hauser <hdhauser@comcast.net>  
**Sent:** Wednesday, February 28, 2024 9:42 PM  
**To:** Jackie Fishman <fishman@consensusplanning.com>; [mgriffie@noreste.org](mailto:mgriffie@noreste.org) <mgriffie@noreste.org>; [sec.dist4@gmail.com](mailto:sec.dist4@gmail.com) <sec.dist4@gmail.com>; [edueweke@juno.com](mailto:edueweke@juno.com) <edueweke@juno.com>; [kbbh@hotmail.com](mailto:kbbh@hotmail.com) <kbbh@hotmail.com>; [ggarcia103@comcast.net](mailto:ggarcia103@comcast.net) <ggarcia103@comcast.net>; 'Maggie Rose' <gypsy.rose46@gmail.com>; [anvanews@aol.com](mailto:anvanews@aol.com) <anvanews@aol.com>; 'Michael Haederle' <haederle@yahoo.com>; Pat Hauser <hdhauser@comcast.net>  
**Cc:** Charlene Johnson <Johnson@consensusplanning.com>; [brookemjordy@gmail.com](mailto:brookemjordy@gmail.com) <brookemjordy@gmail.com>; [staylor@taylortowers.com](mailto:staylor@taylortowers.com) <staylor@taylortowers.com>; [alamedamontoya@gmail.com](mailto:alamedamontoya@gmail.com) <alamedamontoya@gmail.com>; [christinebnvdz@aol.com](mailto:christinebnvdz@aol.com) <christinebnvdz@aol.com>; 'Tina Villegas' <t-marie-v@hotmail.com>; [emyers\\_11@yahoo.com](mailto:emyers_11@yahoo.com) <emyers\_11@yahoo.com>; [stemax1@aol.com](mailto:stemax1@aol.com) <stemax1@aol.com>; [grumpyeh46@comcast.net](mailto:grumpyeh46@comcast.net) <grumpyeh46@comcast.net>; 'BARI Harvey' <boyznbari@msn.com>; 'Sandy Z' <szuschlag58@gmail.com>; 'Bolivar, Silvia A.' <sabolivar@cabq.gov>; [wbenson@bernco.gov](mailto:wbenson@bernco.gov) <wbenson@bernco.gov>; Peggy Norton <peggynorton@yahoo.com>; Steve Wentworth <anvanews@aol.com>  
**Subject:** RE: Meeting Notification - Balloon Fiesta Park / NM United Stadium

Good morning Ms. Fishman: For the record this would seem as if there is another RUSH and PUSH to get this meeting completed due to the short notice and timeframes just to get a box checked.

It would seem problematic to me and others that this process may leave many concerned and interested people and property owners inappropriate time to plan for such a meeting. I believe that giving less than 3 business days' notice regarding a public facilitated meeting about the City of Albuquerque Land Use APPEAL NO.AC-23-22 is problematic and may not comply with appropriate notice for such a complex and long-lasting impact on the future of multiple property owners.

This should be held in an appropriate location such as the City Council chambers or the Couty Chambers as a neutral location. There is possible issue with some individuals not having access to the internet or personal commitments that may have been arranged prior to this short-rushed agenda meeting process.

In the past notification for an EPC meeting allows interested parties appropriate and ample time for planning and preparation. This does none of that.

It is also problematic that comments have been limited in time of 2 minutes. This issue being so complex needs a much better communication process regarding the Neighborhood Associations and the affected property owners.

Based on previous meetings and communication input from non-proximity parties is inconsequential as it relates to the direct and forever impact on, we nearby residents. It is basically in our backyards.

My suggestion and recommendation are to have the meeting scheduled on a weekend such as March 9, 2023 allowing proper planning for all affected parties. Thus, allowing for PEOPLE, PROCESS, AND PROCEDURES to be sensitive to the issues and challenges at hand.

It would also seem appropriate to have the entire City of Albuquerque Balloon Fiesta Park Master Development Plan rewritten vs the current select editing for one specific request as outlined in your communication.

Awaiting a positive response regarding the critical need to reschedule this communication process.

Regards: Pat Hauser

**From:** Jackie Fishman <fishman@consensusplanning.com>

**Sent:** Wednesday, February 28, 2024 7:22 PM

**To:** mgriffie@noreste.org; sec.dist4@gmail.com; edueweke@juno.com; kbbh@hotmail.com; ggarcia103@comcast.net; Maggie Rose <gypsy.rose46@gmail.com>; hdhauser@comcast.net; anvanews@aol.com; Michael Haederle <haederle@yahoo.com>

**Cc:** Charlene Johnson <Johnson@consensusplanning.com>; 'brookemjordy@gmail.com' <brookemjordy@gmail.com>; 'staylor@taylortowers.com' <staylor@taylortowers.com>; alamedamontoya@gmail.com; christinebnvdz@aol.com; Tina Villegas <t-marie-v@hotmail.com>; emyers\_11@yahoo.com; 'stemax1@aol.com' <stemax1@aol.com>; grumpyeh46@comcast.net; BARI Harvey <boyznbari@msn.com>; Sandy Z ([szusschlag58@gmail.com](mailto:szusschlag58@gmail.com)) <szusschlag58@gmail.com>; Bolivar, Silvia A. <sabolivar@cabq.gov>

**Subject:** Meeting Notification - Balloon Fiesta Park / NM United Stadium

Dear Neighbors:

The purpose of this email is to provide notification that the Balloon Fiesta Park Development Plan/Site Plan for Subdivision and Site Plan-EPC for a United New Mexico Soccer Stadium was remanded to the Environmental Planning Commission (EPC) by the Land Use Hearing Officer (LUHO) following an appeal by adjacent neighborhood associations. As part of the remand, the City of Albuquerque is inviting neighborhood associations and neighbors to a facilitated meeting to discuss the request.

The facilitated meeting will be held on **Monday, March 4, 2024, from 5:30 to 7:30 pm.** Representatives from the City of Albuquerque and New Mexico United will be in attendance to answer any questions and listen to community input. The meeting will be facilitated by a City contractor and held online via Google Meet using the link below.

[meet.google.com/xec-uycp-xea](https://meet.google.com/xec-uycp-xea)

Join by phone +1 414-909-3864, PIN 106965974

The EPC hearing will be held on **Thursday March 21, 2024, starting at 8:40 am.** The public is invited to attend the hearing and provide input regarding this project, which will be held via Zoom using the link below:

<https://cabq.zoom.us/j/2269592859> or by calling the following number: 1 301 715 8592 and entering Meeting ID: 226 959 2859

If you have any questions or concerns, please do not hesitate to contact myself at [fishman@consensusplanning.com](mailto:fishman@consensusplanning.com) or you may also contact the City of Albuquerque Planning Department at [devhelp@cabq.gov](mailto:devhelp@cabq.gov).

Sincerely,

**Jacqueline Fishman, AICP**

Principal

Consensus Planning, Inc.

302 Eighth Street NW

Albuquerque, NM 87102

P: 505.764.9801



March 10, 2024

Environmental Planning Commission  
City of Albuquerque  
c/o Silvia Bolivar  
sabolivar@cabq.gov

**Via Electronic Mail**

Re: *Written Comments for March 21, 2024 Hearing – Balloon Fiesta Park Stadium*

Dear Ms. Bolivar:

My name is Brooke Jordy. I live at 9629 Del Fuego Cir NE, Albuquerque, Nm 87113 in the North Edith Corridor neighborhood. Our quiet, rustic neighborhood borders Balloon Fiesta Park. As an affected neighbor, my comments pertaining to the New Mexico United/City of Albuquerque proposal to erect a multi-use stadium in Balloon Fiesta Park are included herein for consideration by the EPC. I vehemently oppose the proposed amendment of the Master Development Plan at Balloon Fiesta Park to permit construction of a multi-use stadium at the park.

On February 16, 2024, a land use hearing officer granted the neighbors' appeal on due process violations made by Consensus Planning. Hearing Officer Chavez's order stated the appeal is to be done *de novo* and the next EPC hearing shall follow *State ex rel. Battershell v. City of Albuquerque*, 1989-NMCA-045. It has yet to be understood by Consensus Planning that this is a *de novo* appeal; as such, many individuals have yet to receive notice of the March 21st EPC hearing. It is worth noting that neighbors/appellants have formally requested that the EPC hearing be deferred to April 2024 to allow for time for parties to be fully prepared and notified by Consensus Planning.

**BACKGROUND**

My husband and I purchased our home—our first—primarily for the location. Living in this part of the North Valley is reminiscent for both of us of growing up in Las Cruces (my husband) and Taos (myself). We chose to buy our first home here to start our family because it is a quiet, rustic area with generational homes. There is more wildlife, livestock, and migratory birds here than most of Albuquerque. Our neighbors use the acequias to water their hay fields, sheep, goats, apple trees, and more. At night, the neighborhood is quiet with little light and no street lights. We can see the stars. I have to check my yard to make sure skunks and racoons are gone before I let my dogs out at night.

Of course, we chose this location knowing the Balloon Fiesta would impact our lives about 9 days a year. However, being so well-established, the Balloon Fiesta employs contractors to monitor sound throughout the Fiesta. The Balloon Fiesta is better at adjusting amplified sound than the City is for other events held throughout the year. During the Fiesta, residents in surrounding areas are given access permits and roadblocks are set up throughout neighborhoods to ensure there is little to no off-site parking on side streets. Of course, taxpayers cover the cost of law enforcement for these road closures and restrictions. However, for 9 days out of a year, it is tolerable.

There are fireworks 2-3 times per Fiesta. Luckily, my dogs are calm and just hide under the couch. For many others, however, this is their nightmare. More pets escape and run away during Fourth of

July, for example, than any other night. Livestock are negatively impacted by fireworks, as are wildlife. The City sets off Fourth of July fireworks from the end of Edith. Many of my neighbors experience literal fallout from those fireworks—fireworks cartridges, gunpowder, and other detritus litter their properties. The air is full of smoke and remains hazy for hours. Veterans and others with PTSD suffer, as well. Fireworks pollute.<sup>1</sup>

## ENVIRONMENTAL IMPACTS

Building a stadium in this otherwise quiet, semi-rural area will introduce noise, light, water, and air pollution to our environment. New Mexico United sets off fireworks regularly. Their fans tailgate; they play drums, set off smoke bombs, yell, and blow vuvuzelas<sup>2</sup> throughout soccer matches. During each game, the team's fan club has a "noisy minute" where the stadium attendees make as much noise as possible.<sup>3</sup>

**Noise Pollution.** Amplified sound from a stadium would create relentless disruption and frustration both for neighbors, animals, and the environment. The Albuquerque Box, the unique weather pattern in our city that makes the Balloon Fiesta an international phenomenon, creates drainage winds that travel in an abnormal pattern.<sup>4</sup> Like the balloons that are carried from the Park to the west over our neighborhood, noise is also carried from the Park to the north and the west. Individuals in the Maria Diers neighborhood, for example, can hear non-amplified sound from the Park. Erecting a stadium in the Park will bring amplified and non-amplified noise to our quiet area. United has stated there will be numerous events at the stadium—concerts, private parties, women's soccer and men's soccer games, etc. However, there are no restrictions in the team's lease to limit events, noise levels, or noise monitoring requirements. Additionally, fireworks bring significant noise pollution to the area. Increasing soccer games and events at the Park will increase fireworks at the Park.

**Light Pollution.** A stadium, no matter how careful its architects are, necessarily brings light pollution. Headlights, parking lights, and stadium and field lights will pollute the relatively dark skies in this section of Albuquerque. Since the Park is situated at a higher elevation than neighborhoods west of the park, lights from the field and the Park shine down on hundreds, potentially thousands, of homes to the west. Even people in Rio Rancho and the Westside of Albuquerque report being able to see the lights from the Park. Migratory birds from the Bosque will be negatively impacted by increased light pollution in the area.<sup>5</sup>

**Water Pollution.** Balloon Fiesta Park borders the North Diversion Channel, which carries Albuquerque's stormwater runoff to the Rio Grande. There also exists a maze of acequias throughout the North Valley, which residents use to water their livestock and agriculture. Fallout

---

<sup>1</sup> Earth.org, *Crowd-Pleasing Fireworks Are Not So Pleasing to the Planet*, available at <https://earth.org/environmental-impact-of-fireworks/>.

<sup>2</sup> Discovery, *Annoying Vuvuzelas Explained*, available at <https://www.youtube.com/watch?v=X15iQFKyqgw>.

<sup>3</sup> KOAT.com, *History and Traditions of New Mexico United*, available at <https://www.koat.com/article/new-mexico-united-history-fan-culture-2024-season/60051431>.

<sup>4</sup> Weather.gov, Balloon Fiesta Feature, available at <https://www.weather.gov/media/abq/Briefings/BalloonFiestaFeatureNew.pdf>.

<sup>5</sup> U.S. Fish & Wildlife Service, *Threats to Birds: Collisions – Nighttime Lighting*, available at <https://www.fws.gov/story/threats-birds-collisions-nighttime-lighting#:~:text=Why%20is%20this%20harmful%20to,colliding%20with%20buildings%20and%20infrastructure>; United Nations, *The Growing Effects of Light Pollution on Migratory Birds*, available at <https://www.un.org/en/un-chronicle/growing-effects-light-pollution-migratory-birds>.

from fireworks at the stadium will land in the acequias and the North Diversion Channel, poisoning so many throughout the Valley and downstream.

**Traffic & Emissions.** Increasing the frequency and volume of vehicles visiting Balloon Fiesta Park to attend stadium events will also bring problematic traffic and air pollution. Vehicle emissions are responsible for soot, smog, and carbon dioxide pollution.<sup>6</sup> In 2023, “Albuquerque was named one of the top 25 worst cities in the nation for ozone pollution.”<sup>7</sup> Building yet another stadium and event center, especially so close to the river and Diversion Channel, is unnecessary and threatens the environmental future of so many New Mexicans.

### **VIOLATIONS OF IDO**

Amending the Park’s Master Development Plan to allow a multi-use stadium to be built would violate core provisions of the City of Albuquerque’s Integrated Development Ordinance (IDO). The IDO is intended to “Protect the abundant natural resources that characterize Albuquerque, including but not limited to Major Public Open Space, Sensitive Lands, the Rio Grande, and the waterways that lead to the river.” Section 1-3(L). Locating a multi-use stadium at Balloon Fiesta Park poses significant negative impacts to adjacent “sensitive lands” due to the Park’s proximity to the Rio Grande and the North Diversion Channel. Increasing light and noise pollution in close proximity to migrating birds and other protected species that inhabit the Bosque will negatively impact those species. Further, the IDO is intended to “provide reasonable protection from possible nuisances and hazards and to otherwise protect and improve public health.” Section 1-3(N). The architect for the United stadium has stated on multiple occasions that the team intends to permit sustained levels of amplified sound at 90 decibels on the playing field.

### **USE OF PUBLIC FUNDS**

The State and City have pledged approximately \$25,000,000 in capital outlay funds to this project. While United and the City both claim taxpayer money is not being spent on the stadium build, Lawrence Rael made the reality clear at the November 16, 2023 City Council meeting. At that meeting, he was asked what the capital outlay funds would be used on if not this project. Mr. Rael responded that if a stadium is not built, the funds would not be spent to improve Balloon Fiesta Park.

### **LEASE AGREEMENT**

On November 16, 2023, the Albuquerque City Council approved an insufficient lease agreement with New Mexico United for their use of the stadium. This short, vague lease is nothing short of ridiculous. To permit a for-profit company to pay only \$35,000 per year for 7 acres of property is unheard of. The City’s lack of concern for specific terms in the lease is problematic and will likely result in United taking advantage of the terms. I urge the EPC to consider the long-term impacts of approving a stadium build, including but not limited to the problems posed by such a vague lease benefitting a for-profit company.

---

<sup>6</sup> U.S. Environmental Planning Agency, *Smog, Soot, and Other Air Pollution from Transportation*, available at <https://www.epa.gov/transportation-air-pollution-and-climate-change/smog-soot-and-other-air-pollution-transportation>

<sup>7</sup> American Lung Association, Press Release, April 18, 2023, available at <https://www.lung.org/media/press-releases/nm-sota-23>.

## CONCLUSION

I strongly oppose approving the site plan to build a multi-use stadium within Balloon Fiesta Park. A stadium will bring noise, light, water, and air pollution to a semi-rural area. It will negatively impact wildlife and livestock in the area, including migrating birds. There is no way to un-ring the bell once this is done. This area already bears the brunt of Balloon Fiesta and the Fourth of July, along with hundreds of other events at the Park each year. I encourage the EPC to take this opportunity to ensure that the environmental future of Albuquerque, the North Edith Corridor, and surrounding neighborhoods are all protected.

Respectfully submitted,

A handwritten signature in cursive script, appearing to read "BJordy", written in black ink. The signature is positioned above a solid horizontal line.

---

Brooke Jordy  
cell: 575-770-4389  
brookemjordy@gmail.com

**From:** [Eddie Myers](#)  
**To:** [Bolivar, Silvia A.](#); [Planning EPC](#); [Planning EPC](#); [Eddie Myers](#)  
**Subject:** Comments for: Remand of BFP/NM United EPC 3.21.24  
**Date:** Sunday, March 10, 2024 9:51:34 PM

---

[EXTERNAL] Forward to [phishing@cabq.gov](mailto:phishing@cabq.gov) and delete if an email causes any concern.

Dear Commissioners,

I am writing this letter on behalf of my entire family, 5 separate households located just west of Balloon Fiesta Park. Consider this letter on behalf of 20 residents. We have owned our land and lived there for several generations, long before Balloon Fiesta Park was even a thought. We have always had livestock and are not the exception. The unincorporated North Valley is agricultural. This means we can (and most do) have horses, sheep, goats, chickens, llamas, cows etc.

We all adamantly oppose the building of the United Soccer Stadium at BFP for many reasons, a few are listed below.

#### Fireworks & Noise Pollution

-Any use of fireworks, either by the team during games or during other events at the stadium, would be devastating, and could result in loss of life, or harm to livestock, property and even people. **It is almost impossible to keep our horses from running through fences and hurting themselves or others during Balloon Fiesta fireworks, 4th of July fireworks and NYE fireworks. The dogs physically tremble in fear some need to be medicated. It literally sounds like and looks like we are at war.**

Additionally, **Military Veterans who live in the neighborhood a triggered by the "war like" sound of fireworks and should not have to worry about this all year long.** We all live in this neighborhood because it is peaceful and quiet. Frankly, our Veterans have given enough and should be allowed to live in peace. We all should.

#### Devastating effects on the Rural Historic Neighborhood Character

- Alameda is very unique. The rural agricultural nature of our neighborhood is directly threatened by the stadium and would forever be changed, not in a good way. We don't have generations of families here for no reason. We are here because we can raise our kids and animals in peace and quiet. We can enjoy nature and wildlife. The stadium would impact the natural feeding area and migration pattern for countless birds. It would encroach on the natural habitat of wildlife. And as I mentioned before, we and our animals would be severely affected by noise, traffic, and lights. I can't stress this enough; the impact would be devastating! We already have to put up with the regular BFP events, we shouldn't have to deal with this as well. Moving a stadium to a rural location is a violation of our lifestyle. Stadiums are not meant to be in rural locations.

#### Reduced Property Values

- My grandparents worked their fingers to the bone to purchase and provide a beautiful plot of land for generations to come. Realtors are already seeing challenges in selling properties in the neighborhood because of the stadium. People want to move to Alameda because of the rural lifestyle, they don't want to live next door to a stadium.

Finally, I come with a solution. Mesa Del Sol is already set up for soccer and events. When asked about this on a recent call, the team said traffic was the reason they stopped considering MDS. I know for a fact the traffic set up leaving an event at the amphitheater is faster than leaving BFP. It is my belief that the real reason they stopped looking at MDS is financial. The city needs to regroup with the team and do what is right, and what makes since, not what is the most financially beneficial to the team. There is a perfectly sensible location for the stadium at Mesa Del Sol.

Please, think about the residents (human and animal). Imagine you live here and own a horse and a couple of dogs. You can sit on your porch listening to birds and enjoying quiet. Now imagine, that peace is taken away and replaced with loud games, traffic, cars honking, blow horns, concerts and fireworks, every weekend. Neighborhood kids have to stay in because of traffic, imagine your animals shaking, running in fear, not eating, and anxious. That's what it will be like. I know this, because this is our life during Balloon Fiesta. We don't want this, and we don't deserve this.

Eddie Myers and Extended Family



March 10, 2024

Environmental Planning Commission City of Albuquerque

C/O Silvia Bolivar [sabolivar@cabq.gov](mailto:sabolivar@cabq.gov) [PlanningEPC@cabq.gov](mailto:PlanningEPC@cabq.gov)

VIA ELECTRONIC MAIL

Dear Ms. Bolivar:

I am writing to declare my opposition to the proposed Soccer Stadium at Balloon Fiesta Park. I live just West of the Park in Alameda. Residents in this area normally enjoy the quiet, rural nature of the valley. Low density housing allows us to farm, raise livestock, and ride the acequias. My own property features a small orchard which allows me to share the bounty of cherries, peaches, nectarines, plums, and apples. During the winter I witness geese and cranes regularly flying overhead as they use the Balloon Park as a major source of food.

There are a few times during the year when that tranquility is upset. The most obvious is the Balloon Fiesta. Yes, it turns our lives upside down. Automobile and pedestrian traffic is intense. Many people park in our neighborhood and walk to the park. Several nights of the Fiesta include fireworks. I'd say that this is the worst part of the celebration. The 4<sup>th</sup> of July is celebrated at the Park, featuring music and fireworks. There are other events, such as the Wine Festival. While we still hear music and the public address system, the fact of the daytime scheduling minimizes the impact.

The reason I am concerned about fireworks has to do with pets, livestock, and wildlife. My dogs are terrified from the first explosion to the last. The Grand Finale is what I imagine from a war zone. Neighbors with livestock such as horses, sheep, goats, etc., struggle with the immediate and after effect of the bombardments. Wildlife was here long before humans. Besides geese and cranes, we share this habitat with hawks, porcupines, raccoons, skunks, and squirrels. We often see photographers with their giant lenses and tripods seeking to capture that one of a kind shot of a rare species. Fireworks and light pollution negatively affect the animals such that their nesting practices (and health) are interrupted.

If you question why I specifically oppose the Soccer stadium, it's because I've read the lease. There is nothing holding United or any subsequent lessee to protect us from the negative impact. They pay lip service to our concerns. Unless specific restrictions are written into the lease, to include penalties for non-compliance, I have no choice but to voice opposition. There should be a limit to the number and nature of events, to the time of day (night verses day events), guarantee no light pollution, no fireworks, and, sound controls.

Finally, I've grown to resent being lied to. We have been told that this is an owner funded project. It is "owner funded" in that it remains City property and the City and State (taxpayers) are spending millions of dollars to benefit United. The amount of rent is a joke, far below market rates for such a property, United promises to pay a measly 10% of the parking revenue to the City, yet, again, the City owns the parking lot, pays for the upkeep of the parking and likely (though not addressed in the lease), bears the liability for injuries and damages in the parking area. This is a great deal for United, not for New Mexico.

James Welty

126 Maria Cir, NW

**From:** [Leslie Linthicum](#)  
**To:** [Bolivar, Silvia A.](#)  
**Subject:** letter of opposition to multi-use stadium at Balloon Fiesta Park  
**Date:** Sunday, March 10, 2024 12:59:01 PM  
**Attachments:** [EPC letter.docx](#)

---

**[EXTERNAL]** Forward to [phishing@cabq.gov](mailto:phishing@cabq.gov) and delete if an email causes any concern.

Dear Mr. Bolivar:

Attached please find my letter in opposition to the proposal to amend the Balloon Fiesta Park Master Development Plan to permit construction of a multi-use stadium, which is scheduled for consideration by the Environmental Planning Commission at its March 21 meeting.

LESLIE LINTHICUM

[leslielinthicum@gmail.com](mailto:leslielinthicum@gmail.com)

505.306-6488

I am writing in opposition of amending the Balloon Fiesta Park masterplan to allow New Mexico United to build a multi-purpose arena on the park. First, let me make clear that my opposition to the stadium at the park should not be interpreted as opposition to United, to soccer, to youth sports or to the growth and development of Albuquerque and Bernalillo County. Rather it is based on my extensive experience as one of the closest neighbors to Balloon Fiesta Park, a number of problems with the city and United's plan and approach and some basic beliefs about community and fairness.

Noise.

I have lived on the western edge of the balloon park since long before it was conceived of or built. As the annual Balloon Fiesta has grown, so has noise and intrusion onto our dead-end street, Edith Boulevard. My neighbors and I hear every word to every song from every band that entertains during the Fiesta and Freedom 4<sup>th</sup>. We also hear current soccer games (unamplified sound) and amplified events at the Golf Center. It is a lot of noise and is often at a volume that shakes the walls of my 130-year-old adobe house. The team's architect, Jared Winchester, said at the March 4 facilitated meeting with neighbors that sound measured from the middle of the field could be 90 decibels. An open stadium, regardless of its design, will add to the already unbearable burden of noise in our neighborhood.

Intensity of use.

At the facilitated meeting with the city and team held March 4, team management tipped their hand about how much they actually intend for the stadium to be used. Ron Patel: "It does need to support itself, because our ownership group is putting the money in. But events can mean a lot of different things. You it could have a quinceañera. You could have a birthday party, right? That's, that's certainly nowhere near the same effect on any of the conditions – traffic, light, sound – as a soccer game. **So could there be 100 events in a year? That's a lot, but if you had all the birthday parties and quinceañeras, I guess it could be.** I'm really nervous to commit to a number." He went on to say that the city would also use the stadium: "**The city's going to have a lot of events, too.**" Without any written commitment from the team or language in the lease with the city, we have no protection against loud amplified events 200 or more days and nights of the year. As a comparison, the Colorado Springs stadium, which United references as an example of a good comparison, hosts events more than 200 days out of the year.

Process.

Representatives from United have attended meetings and at those meetings continually deflected and refused to commit to restrictions that might make the stadium tenable.:

Q. Will you agree to no fireworks?

A. That's something we should talk about.

Q. Will you agree to limit usage to sports, not concerts?

A. We're not Isleta Casino or Live Nation.

Those aren't answers or even assurances. Anything that United says now, without a binding written agreement with the city, cannot be counted on. You are being asked to hand over a prime spot of city property on vague assurances that United will be a good neighbor.

Fairness.

The North Edith corridor, once a rural enclave in the historic Alameda valley, is in danger of becoming an environmental sacrifice zone. As you know, a sacrifice zone is a community that has been made unbearable by repeated environmental alterations through unwanted land use. We have borne the traffic and noise of the Balloon Fiesta, the Balloon Museum, the Golf Center and numerous events held year-round with the permission of the city. The idea seems to be that if a neighborhood already has a lot of development that causes noise pollution, light pollution and traffic that it's a good place to locate more uses that cause noise, light and traffic. I think it's the opposite. When you've asked a neighborhood to shoulder an undue portion of the city's "fun," it is cruel and unfair to add more. Obviously, the city wants to maximize the use of one of its larger city parks. But the park was meant for community recreation, not costly entertainment events. Children and adults play soccer there, as they should. But sitting in a stadium drinking beer while watching professional athletes play isn't recreation; it is entertainment. That is probably why the Balloon Fiesta Park masterplan, when it was updated in 2012 with input from a host of parties, including neighbors, specifically outlawed that use. Because they knew a city park isn't the place for a large stadium. The promise was made then to neighbors that this wouldn't happen. I would ask you to keep that promise.

Thank you.

Leslie Linthicum  
10312 Edith Blvd. NE

**From:** [Tania Gonzalez](#)  
**To:** [Bolivar, Silvia A.](#)  
**Subject:** EPC Hearing for Ballon Fiesta/ United Stadium  
**Date:** Friday, March 8, 2024 1:19:41 PM

---

**[EXTERNAL]** Forward to [phishing@cabq.gov](mailto:phishing@cabq.gov) and delete if an email causes any concern.

Hello,

My name is Tania Gonzalez and my husband Luis Gonzalez and live at 10435 Edith Blvd NE Albuquerque NM, 87113. We are building our dream home here and plan to live here for the rest of our lives. This property has been in my family since the late 60's when my grandparents Joe and Doris Pelot bought this to raise their family here after moving to New Mexico from Wisconsin. Both of my grandparents lived here until they passed away. I also grew up on this property and would tell my husband how wonderful it is to live in Alameda just outside of the city and how quiet it is here. We have built our home so that we can enjoy the view of the Sandia Mountains, the balloons during the fiesta, also the wildlife around us. We enjoy sitting on our Porch watching the Geese, Cranes that fly over each morning and evening, they go from the Bosque to Balloon Fiesta Park and then back. There is also an owl that lives between the trees in our yard and our neighbor, there are also raccoons, squirrels, skunks, rabbits, coyotes, and those that have livestock or dogs that loud noise can scare them. We all try to live in harmony with them, this is how the country should be. We are worried about the lights and noise from the Soccer Stadium affecting the lives of those who live in our community and the wildlife. Yes, during Balloon Fiesta we have noise, and traffic can be crazy for 9 days each year, but Balloon Fiesta does a great job minimizing the impact too our community and wildlife by monitoring the noise during each event. Thank you for taking the time to listen to our concerns.

Sincerely,

Luis and Tania Gonzalez



**Bolivar, Silvia A.**

---

**From:** Maggie Rose <gypsy.rose46@gmail.com>  
**Sent:** Friday, March 8, 2024 12:33 PM  
**To:** Bolivar, Silvia A.  
**Subject:** Opposition to Soccer Stadium  
**Attachments:** Opposed to Soccer Stadium letter.pdf

[EXTERNAL] Forward to [phishing@cabq.gov](mailto:phishing@cabq.gov) and delete if an email causes any concern.

Please note the enclosed letter of opposition to United Soccer proposed stadium.

Maggie Rose

## I am adamantly opposed to locating the New Mexico United Soccer Stadium at Balloon Fiesta Park

My name is Maggie Rose and I am the President of The Maria Diers Neighborhood Association. I am opposed to the Soccer Stadium for many reasons, but the biggest reason is it will have a DEVASTING impact on my home, our neighborhood and our rural way of life. The geese have a flight path right where the proposed stadium would be. Every morning and night they fly over Balloon Field from the river and every evening they fly back to the river. What will the lights and noise do to their flight pattern? Where will they go?

During the 4<sup>th</sup> of July and the two week-ends of Balloon Fiesta, people with animals have to take extra care to be with the animals, lock them up, or stay with them because the loud noises and strange lights frighten them. Studies have shown that animals under that kind of stress for more than a few days fail to reproduce, stop laying eggs, lower milk production, and loose hair, to name a few things. Larger birds fly away from the lights and noise and may not have the strength to return to the nests. I have found dead babies and eggs in nests. We can handle Balloon Fiesta but not 17 home Soccer Games plus concerts and other events. We already have a mess with traffic on Alameda. More and more people are moving into this area and at heavy traffic times it can take an hour or more to get home.

When I'm outside working in my yard I hear kids playing Soccer on the Balloon field. They are cheering, whistles blowing; I think its sweet *but not 10,000 screaming Soccer fans*. I'm involved because I care about my home and our rural way of life. I've worked hard and have had many jobs in order to have a place in the North Valley. None of you live out here. You don't care if you ruin our way of life.

You have shown no real effort to work together. We are willing to sit down and talk with United Soccer but a hastily thrown together zoom meeting is not the way to accomplish that. Our night skies are important to us. Have you considered putting a roof on the stadium? Is United willing to turn lights off at a reasonable time? Will United limit the amount of concerts they have? Will you prohibit fireworks and other loud noise makers? I thought mediation was to talk about problems and try to solve them. Will we have any input to shape how this will impact our community?

**Traffic** is another problem I'm **very worried** about. During Balloon Fiesta we know when we can get in and out. It's only for a week and 2 weekends. Soccer United will have 17 home games, concerts, and women's soccer. When will the neighbors ever get a break? What if we need a Doctor or urgent care? I won't be able to go to play Mahjongg; friends won't be able to get into see me. I won't be able to get out. I'll be a prisoner in my on home. The presence of this stadium would further isolate me.

"Mayor Keller wants this, so let's get it done." Those were Pat Davis's exact words at a City Council meeting. I think we have been marginalized and ignored. I'll fight this every way I know how. Of course the lease is for \$35,000 a year for 30 years and the possibility to renew it for another 30, is was written for Soccer United. I'm afraid we haven't left our kids and grandkids with a lot to work with but taxes and debts to help Soccer United.

Maggie Rose

## Bolivar, Silvia A.

---

**From:** Michael Haederle <haederle@yahoo.com>  
**Sent:** Thursday, February 29, 2024 5:19 PM  
**To:** 'peggynorton@yahoo.com'; Baca, Vanessa  
**Cc:** 'Pat Hauser'; Hummell, Tyson; 'Philip Crump'; Flores, Suzanna A.; Bolivar, Silvia A.; 'Jackie Fishman'; Aranda, James M.; 'Cc: Maggie Rose'; 'Steve Wentworth'; 'Evelyn Harris'; 'Brooke Jordy'; 'boyznbari@msn.com'; 'Sandy Zuschlag'; 'Steve Taylor'; 'Steve Horschheimer'; 'Edie Myers'; 't-marie-v@hotmail.com'; 'Christine Benavidez'; 'Lorraine Montoya'  
**Subject:** Re: Balloon Fiesta Park and NM United

[EXTERNAL] Forward to [phishing@cabq.gov](mailto:phishing@cabq.gov) and delete if an email causes any concern.

All:

Ms. Baca's assertion about the NECA boundaries is based on incorrect information. We currently consider our eastern boundary to be the North Diversion Channel, which abuts Balloon Fiesta Park. It would be nonsensical to exclude all the homes in our neighborhood (including ours) that lie on the east side of Edith Boulevard. Whoever drew the map got it wrong.

Thanks,  
Michael  
Vice President, North Edith Corridor Association

On Thursday, February 29, 2024 at 04:53:49 PM MST, Baca, Vanessa <vanessabaca@cabq.gov> wrote:

Hi Peggy.

Thank you for your earlier e-mail inquiries regarding developer notice for the property at 5601 Balloon Fiesta Parkway.

The Neighborhood Association Recognition Ordinance (NARO) stipulates in Section §14-8-2-4 (B) (5) that for the purposes of notice, recognized neighborhood coalitions shall receive notice per the boundaries of member associations or groups only, and not for any individual members. In this particular case, the property site in question is within the boundaries of the Wildflower Neighborhood Association, which is itself a member of the District 4 Coalition. As such, both the Wildflower NA and the D4 Coalition received developer notice, as required by the Integrated Development Ordinance (IDO).

To address your specific question about the North Edith Commercial Corridor Association (NEC), the reason that the North Valley Coalition was not notified on behalf of NEC is because the property site in question is not adjacent to the eastern boundary of the NEC. The IDO defines adjacency as: those properties that are abutting or separated only by a street, alley, trail, or utility easement, whether public or private.

I have attached a map of the NEC boundaries that are on file with the Office of Neighborhood Coordination (ONC). As you can see demonstrated by the red outline, the eastern boundary of the NEC is Edith Boulevard. The properties which are adjacent to the subject site are not within the boundaries of the NEC, nor is the subject site within the boundaries of the NEC.

Please let me know if you need additional information.



## Vanessa Baca

Manager

Office of Neighborhood Coordination (ONC) | City Council Department | City of Albuquerque

(505) 768-3331 Office

E-mail: [vanessabaca@cabq.gov](mailto:vanessabaca@cabq.gov)

Website: [www.cabq.gov/neighborhoods](http://www.cabq.gov/neighborhoods)



---

**From:** Peggy Norton <peggynorton@yahoo.com>

**Sent:** Thursday, February 29, 2024 1:18 PM

**To:** Pat Hauser <hdhauser@comcast.net>; Hummell, Tyson <thummell@cabq.gov>; Philip Crump <phcrumpsf@gmail.com>; Flores, Suzanna A. <Suzannaflores@cabq.gov>; Bolivar, Silvia A. <sabolivar@cabq.gov>; Jackie Fishman <fishman@consensusplanning.com>; Aranda, James M. <jmaranda@cabq.gov>

**Cc:** Maggie Rose <gypsy.rose46@gmail.com>; Michael Haederle <haederle@yahoo.com>; Steve Wentworth <anvanews@aol.com>; Evelyn Harris <grumpyeh46@comcast.net>; Brooke Jordy <brookemjordy@gmail.com>; boyznbari@msn.com; Sandy Zuschlag <szuschlag58@gmail.com>; Steve Taylor <staylor@taylortowers.com>; 'Steve Horchheimer' <stemax1@aol.com>; 'Edie Myers' <emyers\_11@yahoo.com>; t-marie-v@hotmail.com; Christine Benavidez <christinebnvdz@aol.com>; 'Lorraine Montoya' <alamedamontoya@gmail.com>

**Subject:** Re: Balloon Fiesta Park and NM United

Thanks James. I have a call in to ONC and I see Suzanna is on this email. The NARO is clear in defining Coalition membership: recognized neighborhood associations, neighborhood associations, homeowner associations, etc. (Page 8). Note that recognized NA's and NA's are two separate entities. Recognized neighborhood coalitions shall receive notices per the boundaries of member associations or groups only, and not for any individual members. (Page 9). Nothing requires the member associations or groups to be recognized, and obviously groups do not have that pathway. North Edith Corridor is a member of the Coalition and we should be included in notification.

Peggy Norton, President

North Valley Coalition

On Thursday, February 29, 2024 at 11:57:15 AM MST, Aranda, James M. <[jmaranda@cabq.gov](mailto:jmaranda@cabq.gov)> wrote:

Peggy,

Much thanks for reaching out regarding this matter. After previously discussing the matter with Legal, my understanding of the notice requirements is that neighborhood coalitions are only notified if there is a recognized neighborhood association within the coalition boundaries.

As with all EPC cases, the Office of Neighborhood Coordination determines which associations and coalitions are required to be notified. According to the public record associated with the request, the North Valley Coalition was not included on the original notification list, nor was NVC included on the most current notification list. My understanding as to why NVC was not notified is because there were no recognized neighborhood associations within the notification area that are part of NVC.

Please be aware that while the ZEO is responsible for interpreting the provisions of the IDO, I do not have the authority to establish notification boundaries or requirements, nor do I have the authority to interpret NARO's provisions. This being the case, I recommend discussing NARO's notification requirements with ONC staff and leadership. I apologize for any confusion or inconvenience.

Respectfully,



## JAMES M. ARANDA, MCRP

deputy director + zeo

505-924-3361

[jmaranda@cabq.gov](mailto:jmaranda@cabq.gov)

[cabq.gov/planning](http://cabq.gov/planning)

---

**From:** Peggy Norton <[peggynorton@yahoo.com](mailto:peggynorton@yahoo.com)>

**Sent:** Thursday, February 29, 2024 11:08 AM

**To:** Pat Hauser <[hdhauser@comcast.net](mailto:hdhauser@comcast.net)>; Hummell, Tyson <[thummell@cabq.gov](mailto:thummell@cabq.gov)>; Philip Crump <[phcrumpsf@gmail.com](mailto:phcrumpsf@gmail.com)>; Flores, Suzanna A. <[Suzannaflores@cabq.gov](mailto:Suzannaflores@cabq.gov)>; Aranda, James M. <[jmaranda@cabq.gov](mailto:jmaranda@cabq.gov)>; Bolivar, Silvia A. <[sabolivar@cabq.gov](mailto:sabolivar@cabq.gov)>; Jackie Fishman <[fishman@consensusplanning.com](mailto:fishman@consensusplanning.com)>

**Cc:** Maggie Rose <[gypsy.rose46@gmail.com](mailto:gypsy.rose46@gmail.com)>; Michael Haederle <[haederle@yahoo.com](mailto:haederle@yahoo.com)>; Steve Wentworth <[anvanews@aol.com](mailto:anvanews@aol.com)>; Evelyn Harris <[grumpyeh46@comcast.net](mailto:grumpyeh46@comcast.net)>; Brooke Jordy <[brookemjordy@gmail.com](mailto:brookemjordy@gmail.com)>; boyznbari@msn.com; Sandy Zuschlag <[szuschlag58@gmail.com](mailto:szuschlag58@gmail.com)>; Steve Taylor <[staylor@taylortowers.com](mailto:staylor@taylortowers.com)>; 'Steve Horchheimer' <[stemax1@aol.com](mailto:stemax1@aol.com)>; 'Edie Myers' <[emyers\\_11@yahoo.com](mailto:emyers_11@yahoo.com)>; t-marie-v@hotmail.com; Christine Benavidez <[christinebnvdz@aol.com](mailto:christinebnvdz@aol.com)>; 'Lorraine Montoya' <[alamedamontoya@gmail.com](mailto:alamedamontoya@gmail.com)>

**Subject:** Re: Balloon Fiesta Park and NM United

**[EXTERNAL]** Forward to [phishing@cabq.gov](mailto:phishing@cabq.gov) and delete if an email causes any concern.

I looked further into this and I will be communicating with Suzanna and James. My interpretation of NARO requires us to be notified.

Peggy Norton, President

North Valley Coalition

On Wednesday, February 28, 2024 at 07:12:33 PM MST, Jackie Fishman <[fishman@consensusplanning.com](mailto:fishman@consensusplanning.com)> wrote:

Thanks for getting back to us.

**Jacqueline Fishman, AICP**

Principal

Consensus Planning, Inc.

302 Eighth Street NW

Albuquerque, NM 87102

P: 505.764.9801

---

**From:** Peggy Norton <[peggynorton@yahoo.com](mailto:peggynorton@yahoo.com)>

**Sent:** Wednesday, February 28, 2024 6:55 PM

**To:** Pat Hauser <[hdhauser@comcast.net](mailto:hdhauser@comcast.net)>; [thummell@cabq.gov](mailto:thummell@cabq.gov); Philip Crump <[phcrumpsf@gmail.com](mailto:phcrumpsf@gmail.com)>; [suzannaflores@cabq.gov](mailto:suzannaflores@cabq.gov); Aranda, James M. <[jmaranda@cabq.gov](mailto:jmaranda@cabq.gov)>; Bolivar, Silvia A. <[sabolivar@cabq.gov](mailto:sabolivar@cabq.gov)>; Jackie Fishman <[fishman@consensusplanning.com](mailto:fishman@consensusplanning.com)>

**Cc:** Maggie Rose <[gypsy.rose46@gmail.com](mailto:gypsy.rose46@gmail.com)>; Michael Haederle <[haederle@yahoo.com](mailto:haederle@yahoo.com)>; Steve Wentworth <[anvanews@aol.com](mailto:anvanews@aol.com)>; Evelyn Harris <[grumpyeh46@comcast.net](mailto:grumpyeh46@comcast.net)>; Brooke Jordy <[brookemjordy@gmail.com](mailto:brookemjordy@gmail.com)>; [boyznbari@msn.com](mailto:boyznbari@msn.com); Sandy Zuschlag <[szuschlag58@gmail.com](mailto:szuschlag58@gmail.com)>; Steve Taylor <[staylor@taylortowers.com](mailto:staylor@taylortowers.com)>; 'Steve Horchheimer' <[stemax1@aol.com](mailto:stemax1@aol.com)>; 'Edie Myers' <[emyers\\_11@yahoo.com](mailto:emyers_11@yahoo.com)>; [t-marie-v@hotmail.com](mailto:t-marie-v@hotmail.com); Christine Benavidez <[christinebnvdz@aol.com](mailto:christinebnvdz@aol.com)>; 'Lorraine Montoya' <[alamedamontoya@gmail.com](mailto:alamedamontoya@gmail.com)>

**Subject:** Re: Balloon Fiesta Park and NM United

I checked a couple boundaries and they are correct to omit us.

Peggy Norton, President

North Valley Coalition

On Wednesday, February 28, 2024 at 05:42:20 PM MST, Jackie Fishman <[fishman@consensusplanning.com](mailto:fishman@consensusplanning.com)> wrote:

Ms. Norton –

Thanks for your email. The Office of Neighborhood Coordination determines which associations and coalitions are required to be notified – the NVC was not included on the original list or the most current list. I've copied Susie Flores (ONC) and James Aranda (ZEO) on this email and you are welcome to discuss your concern about notification to the NVC with both of them.

**Jacqueline Fishman, AICP**

Principal

Consensus Planning, Inc.

302 Eighth Street NW

Albuquerque, NM 87102

P: 505.764.9801

---

**From:** Peggy Norton <[peggynorton@yahoo.com](mailto:peggynorton@yahoo.com)>

**Sent:** Wednesday, February 28, 2024 5:29 PM

**To:** Jackie Fishman <[fishman@consensusplanning.com](mailto:fishman@consensusplanning.com)>; Pat Hauser <[hdhauser@comcast.net](mailto:hdhauser@comcast.net)>; [thummell@cabq.gov](mailto:thummell@cabq.gov); Philip Crump <[phcrumpsf@gmail.com](mailto:phcrumpsf@gmail.com)>

**Cc:** Maggie Rose <[gypsy.rose46@gmail.com](mailto:gypsy.rose46@gmail.com)>; Michael Haederle <[haederle@yahoo.com](mailto:haederle@yahoo.com)>; Steve Wentworth <[anvanews@aol.com](mailto:anvanews@aol.com)>; Evelyn Harris <[grumpyeh46@comcast.net](mailto:grumpyeh46@comcast.net)>; Brooke Jordy <[brookemjordy@gmail.com](mailto:brookemjordy@gmail.com)>; [boyznbari@msn.com](mailto:boyznbari@msn.com); Sandy Zuschlag <[szuschlag58@gmail.com](mailto:szuschlag58@gmail.com)>; Steve Taylor <[staylor@taylortowers.com](mailto:staylor@taylortowers.com)>; 'Steve Horchheimer' <[stemax1@aol.com](mailto:stemax1@aol.com)>; 'Edie Myers' <[emyers\\_11@yahoo.com](mailto:emyers_11@yahoo.com)>; [t-marie-v@hotmail.com](mailto:t-marie-v@hotmail.com); Christine Benavidez <[christinebnvdz@aol.com](mailto:christinebnvdz@aol.com)>; 'Lorraine Montoya' <[alamedamontoya@gmail.com](mailto:alamedamontoya@gmail.com)>

**Subject:** Re: Balloon Fiesta Park and NM United

As a coalition representative who never received notice on the first round, I would like to comment on this. I have not read the remand order from the Land Use Hearing Officer, but evidently, the legally required notification was lacking. I am hoping we will be included in this round, but I am not sure of that. Giving less than 5 days notice for a public facilitated meeting about the soccer stadium hardly seems to comply with appropriate notice. Generally, notification for an EPC meeting allows interested parties 15 days to request a meeting. Perhaps this remand order negated that requirement. I am a little behind in this case and will look for the remand order, but I wanted to get these comments in. Additionally, Monday is a City Council meeting.

Peggy Norton, President

North Valley Coalition

On Wednesday, February 28, 2024 at 02:30:59 PM MST, Philip Crump <[phcrumpsf@gmail.com](mailto:phcrumpsf@gmail.com)> wrote:

Thank you, Jackie and Pat.

I can send a Google Meet invitation for Monday the 4th, starting at 5:30, for two hours.

Is that agreeable?

Respectfully,

Philip



**PHILIP CRUMP, Mediator & Facilitator**

1301 Luisa Street Santa Fe, New Mexico 87505

[www.pcmediate.com](http://www.pcmediate.com) Txt/VM: (505) 989-8558

*When I walked out of the gate, I knew that if I continued to hate these people, I would still be in prison. --Nelson Mandela*

On 2/28/2024 2:04 PM, Jackie Fishman wrote:

Pat –

I agree that the meeting shouldn't be during the day as that would prevent working people from participating. The meeting would be via Zoom and in the evening.

I spoke with Brooke this morning and proposed this coming Monday evening for the facilitated meeting. She was agreeable to that date and so I have notified our team. I'm hoping that is agreeable to you as well.

Our intent is to be back in front of the EPC for the March 21<sup>st</sup> hearing. We are gearing up this afternoon to start sending out notifications today. The representatives from the City recognized associations, as well as representatives from the County neighborhood associations, will be receiving an official email notification today from my office. We are also sending out certified mail notices to all property owners within the 100-foot buffer; that list has been vetted and confirmed with the Planning Department's GIS Manager. We are also sending first class mail to the other property owners that were on your map, everyone who attended any of the seven meetings that provided a mailing address, and every address along the east side of Edith. Parks and Rec will be going door to door with copies of the notice as well. This means some people will likely get 2 or 3 notices in our effort.

I suspect the main agenda item is going to be sound. Let me know if there are specific other items that you would like our team to address.

Please feel free to give me a call to discuss.

**Jacqueline Fishman, AICP**

Principal

Consensus Planning, Inc.

302 Eighth Street NW

Albuquerque, NM 87102

P: 505.764.9801

---

**From:** Pat Hauser <[hdhauser@comcast.net](mailto:hdhauser@comcast.net)>  
**Sent:** Wednesday, February 28, 2024 11:50 AM  
**To:** Jackie Fishman <[fishman@consensusplanning.com](mailto:fishman@consensusplanning.com)>  
**Cc:** Maggie Rose <[gypsy.rose46@gmail.com](mailto:gypsy.rose46@gmail.com)>; Michael Haederle <[haederle@yahoo.com](mailto:haederle@yahoo.com)>; Steve Wentworth <[Anvanews@aol.com](mailto:Anvanews@aol.com)>; Peggy Norton <[peggynorton@yahoo.com](mailto:peggynorton@yahoo.com)>; Evelyn Harris <[grumpyeh46@comcast.net](mailto:grumpyeh46@comcast.net)>; Brooke Jordy <[brookemjordy@gmail.com](mailto:brookemjordy@gmail.com)>; [boyznbari@msn.com](mailto:boyznbari@msn.com); Sandy Zuschlag <[szuschlag58@gmail.com](mailto:szuschlag58@gmail.com)>; Steve Taylor <[staylor@taylortowers.com](mailto:staylor@taylortowers.com)>; 'Steve Horchheimer' <[stemax1@aol.com](mailto:stemax1@aol.com)>; 'Edie Myers' <[emyers\\_11@yahoo.com](mailto:emyers_11@yahoo.com)>; [t-marie-v@hotmail.com](mailto:t-marie-v@hotmail.com); Christine Benavidez <[christinebnvdz@aol.com](mailto:christinebnvdz@aol.com)>; 'Lorraine Montoya' <[alamedamontoya@gmail.com](mailto:alamedamontoya@gmail.com)>  
**Subject:** RE: Balloon Fiesta Park and NM United

Good morning Ms. Fishman: Thanks for the message regarding the proposed meeting. Your telephone number was blocked on my cellphone as a potential Spam number.

Not sure why maybe since you are not in my contact list.

Based on my limited knowledge regarding the meeting it would seem as if it is being planned as a Zoom or something of that nature.

My experience has been that if such a meeting is conducted during the day it seriously hampers many individuals from attending due to their business or work schedules.

I would like to contact several of the other Associations and get their input regarding a possible best time to proceed with such a meeting.

It would also be helpful to know the agenda items and what is planned for possible discussion items that will impact we the property owners.



I have taken the liberty to copy several individuals in on our communication regarding a proposed meeting.

Thanks in advance for working with us on this subject.

Regards: Pat Hauser

---

**From:** Jackie Fishman <[fishman@consensusplanning.com](mailto:fishman@consensusplanning.com)>  
**Sent:** Wednesday, February 28, 2024 8:51 AM  
**To:** [hdhauser@comcast.net](mailto:hdhauser@comcast.net)  
**Cc:** [gypsy.rose46@gmail.com](mailto:gypsy.rose46@gmail.com); [phcrumpsf@gmail.com](mailto:phcrumpsf@gmail.com)  
**Subject:** Balloon Fiesta Park and NM United  
**Importance:** High

Hi Pat –

I left you a voicemail yesterday in regard to the EPC remand. We would like to schedule a meeting to discuss the project and I've copied the meeting facilitator. We are working on notification and have greatly expanded the list of who we will be sending notification to. Given the number of associations and individuals involved, I would like to work with you to pick a meeting date next week and then my office will add the date to the notification. Could you or Maggie please either email me back or call me to discuss your availability next week?

Thanks, and hope to hear from you soon.

**Jacqueline Fishman, AICP**

Principal

Consensus Planning, Inc.

302 Eighth Street NW

Albuquerque, NM 87102

P: 505.764.9801

**From:** [Michael Haederle](#)  
**To:** [Bolivar, Silvia A.](#)  
**Cc:** [Pat Hauser](#); [Tina Villegas](#); [Brooke Jordy](#); [Sandy Zuschlag](#); [Evelyn Harris](#); [Steve Wentworth](#); [Maggie Rose](#); [Peggy Norton](#); [Leslie Linthicum](#); [LuElena Gonzales](#)  
**Subject:** Letter of Opposition Regarding Multi-Use Stadium at Balloon Fiesta Park  
**Date:** Sunday, March 10, 2024 11:53:15 AM  
**Attachments:** [Balloon Fiesta Park 3.21.24 EPC Hearing.docx](#)  
[N.M. United Facilitated Discussion Transcript \(3.4.24\).docx](#)

---

[EXTERNAL] Forward to [phishing@cabq.gov](mailto:phishing@cabq.gov) and delete if an email causes any concern.

Dear Ms. Bolivar:

Attached please find a letter in opposition to the proposal to amend the Balloon Fiesta Park Master Development Plan to permit construction of a multi-use stadium, which is scheduled for consideration by the Environmental Planning Commission at its March 21 meeting.

I have also taken the liberty of attaching a transcript of the March 4 facilitated meeting between neighbors and New Mexico United representatives, which captures many of our concerns and the team's responses.

Thanks for your assistance.

Best regards,

Michael Haederle  
505.453.6072

Dear Ms. Bolivar:

March 10, 2024

I am a resident of North Edith Boulevard in unincorporated Bernalillo County, writing in opposition to the proposed amendment of the Master Development Plan at Balloon Fiesta Park to permit construction of a multi-use stadium at the park.

The planned operation of the stadium – home games for men’s and women’s soccer teams with up to 10,000 fans, plus its unfettered use for other noise-and-light-generating events like concerts, festivals, parties, weddings and the like – amounts to putting an amusement park in our backyards.

There are a number of concerns that we would like the city Planning staff and the Environmental Planning Commission to take seriously.

For starters, these uses would violate core provisions of the City of Albuquerque’s Integrated Development Ordinance (IDO). The first of the IDO’s General Provisions – 1-3(A) – states that the IDO’s purpose is to “Implement the adopted Albuquerque/Bernalillo County Comprehensive Plan (ABC Comp Plan), as amended.”

The area along North Edith Boulevard adjacent to the park – the historic Camino Real – retains a quiet, semi-rural character, with predominantly A-1 zoning. Many people follow traditional practices of keeping livestock, cutting hay and maintaining small gardens, with open areas used by waterfowl from the nearby Rio Grande.

This area’s unique character is recognized in the Albuquerque/Bernalillo County Comprehensive Plan: “[T]here are several communities in the unincorporated area that have historic properties worthy of protection. In the North Valley, a number of historic buildings and properties are located along North Edith Boulevard between Osuna Rd. and the Sandia Indian Reservation part of the original El Camino Real route and the road from Albuquerque to Bernalillo.” (p. 11-13)

The Comprehensive Plan further states: “In order for rural and agrarian areas to remain viable and sustainable, efforts to increase density and intensity need to be concentrated in existing urban areas, drawing the gravity of development away from the outlying areas. Additionally, future growth should be respectful of and compatible with the surrounding context, whether urban or rural, to ensure the full range of lifestyle options.” (p. 11-5)

The IDO is also meant to “Protect all communities, especially those that have been historically underserved.” 1-3(D) and “Protect the quality and character of residential neighborhoods.” 1-3(E)

The fact is, construction of a stadium at Balloon Fiesta Park would financially benefit a few business people – the team’s owners – at the expense of hundreds of predominantly Hispanic working-class residents living in neighborhoods adjacent to the park, whose property values would be irreparably damaged.

The IDO is further intended to “Protect the abundant natural resources that characterize Albuquerque, including but not limited to Major Public Open Space, Sensitive Lands, the Rio Grande, and the waterways that lead to the river.” 1-3(L) Locating a multi-use stadium at Balloon Fiesta Park, with its parking and noise impacts, would severely curtail the ability of others to use the park. Loud activities at the stadium – particularly in the evening – would also pose negative impacts to adjacent “sensitive lands,” due to the park’s proximity to the Rio Grande and the North Diversion Channel, which drains into the river.

Finally, the IDO is meant to “Provide reasonable protection from possible nuisances and hazards and to otherwise *protect and improve public health.*” [*italics added*] 1-3(N) The architect for the New Mexico United Soccer team has stated on multiple occasions that the team intends to permit sustained levels of amplified sound at 90 decibels on the playing field.

Guidelines published by the [Centers for Disease Control and Prevention](#) and the [American Speech-Language-Hearing Association](#) state that exposure to sound volumes in that range are likely to cause hearing damage. In the interests of protecting public health, the Environmental Planning Commission (EPC) has an obligation to set reasonable limits on sound levels that would be permitted at the stadium.

Furthermore, the sound study conducted for New Mexico United by a Virginia-based consultant as part of its application relied entirely on simulations, rather than in-situ testing with live sound. North Edith residents with decades of experience living with the noise impacts from events at Balloon Fiesta Park know that amplified sound – particularly bass frequencies – project downhill and across the valley floor at unacceptable levels, to the extent that our walls often vibrate, even with doors and windows closed.

Some EPC commissioners at the November 2023 hearing were dismissive of neighbors’ concerns about sound, suggesting that they could simply be addressed by the city’s existing sound ordinance. However, many North Edith residents can attest to many years of frustration in trying to get Balloon Fiesta Park administrators to enforce that ordinance. In fact, David Simon, the city’s Parks and Recreation director, has admitted that they have historically done a poor job of doing so.

But chronic exposure to noise – intrusive unwanted sound – is more than a mere annoyance. It poses a serious risk for multiple physiological and neurological diseases.

A newly published study in the [Journal of Exposure Science and Environmental Epidemiology](#) states, “Noise is one of the most ubiquitous environmental pollutants, as suggested by reports from the World Health Organization and the European Environment Agency that noise exposure is a major public health threat affecting both physical and mental health.”

The authors, an international group of experts in cardiology and psychiatry, summarize a few of the potential harms this way: “While recent years have yielded a wealth of evidence linking environmental noise exposure primarily to cardiovascular ailments . . . an

increasing body of compelling research and conclusive findings confirms that exposure to noise, particularly from sources such as traffic, can potentially impact the central nervous system. These harms of noise increase the susceptibility to mental health conditions such as depression, anxiety, suicide, and behavioral problems in children and adolescents. From a mechanistic perspective, several investigations propose direct adverse phenotypic changes in brain tissue by noise (e.g. neuroinflammation, cerebral oxidative stress), in addition to feedback signaling by remote organ damage, dysregulated immune cells, and impaired circadian rhythms, which may collectively contribute to noise-dependent impairment of mental health.”

No one, including residents living near the Balloon Park, should be exposed to these hazards. The EPC’s fundamental mission – to consider the potential *environmental* impacts of new development in the city – compels it to seriously weigh these concerns as they pertain to the proposed stadium. At a minimum, the EPC should require significant and demonstrable mitigation of any sound impacts on the surrounding neighborhoods, both by attenuating volumes and limiting the frequency with which noise is produced.

But, given the city’s abysmal record of sound ordinance enforcement at the park, and because New Mexico United is likely unable and/or unwilling to agree to that, the better course would be to deny the Master Development Plan amendment altogether.

The park’s existing Master Development Plan prohibits construction of a stadium for a good reason: it would violate provisions of the Comprehensive Plan and IDO, and it would demonstrably endanger public health, both for those attending events and residents in the surrounding neighborhoods.

Balloon Fiesta Park is clearly not an appropriate location for a multi-use stadium. The city should be held to the commitments it has made to ensure the well-being of *all* of the citizens living in the metropolitan area, not just soccer fans or members of the business community. For these reasons the petition to amend the Master Development Plan must be denied.

Sincerely,

Michael Haederle  
Vice President, North Edith Corridor Association

10312 Edith Boulevard NE  
505.453.6072



# New Mexico United Stadium Facilitated Discussion

## Philip Crump, Mediator

### March 4, 2024

(Edited to remove most discussions of technical difficulties with the Google meeting format.)

#### **Tina Villegas**

Mr. Crump, at the top of the chat box, it says that all messages are deleted when the call ends. Do you still? Will you still receive those emails?

#### **Philip Crump**

So, I will record those before the meeting closes. Thank you. Thank you. It's a good question. And I need to remember to do that. It does, yeah. And there's Tyson. Liz, Leslie, Peggy. And there's Jackie. Well, it looks like there are fewer people who are coming in. So I'm going to go ahead and get started. So my name is, for those of you who haven't met previously, my name is Philip Crump. I'm a mediator and facilitator in private practice. I live now in Santa Fe. I lived in Albuquerque for 20 years previously and have been involved with City of Albuquerque land use facilitation program for about 25 years. So I'm familiar with the city. I do not represent myself as an expert in any code or zoning and familiar with a lot of things, but I leave the expertise up to the experts and oftentimes neighbors who are very knowledgeable about INDISTINCT. So this, this is the second facilitated meeting with regard to the proposed New Mexico United stadium to be located at a Balloon Fiesta Park. Many of you were in the previous facilitated meeting, or one of the other public meetings that have been held or the hearing. So how this works, first, we're going to do a little bit of introduction. I'm going to ask the planning team to introduce themselves, just so everybody knows who's here. There are a lot of people on this call – about 40 people so far – so we're not going to introduce everybody. At this meeting, I am going to be recording in English. I have just started the recording and the transcribing. The reason for the recording is to help me produce a more accurate report of this meeting. I am required to produce that report within 48 hours, I will send it out to everyone for whom I have an email address. When you receive the report, look it over carefully. And let me know if there are any errors of omission – something important that was said that was not reported. Or commissions – something that I reported inaccurately. I will then issue an amendment, a corrective amendment. We really want the report to be accurate, it will go to everyone on this meeting, a few others who are interested, but not present, as well as the EPC. It becomes part of the official record. And following the introductions, then I understand there are a couple of primary issues. I don't want to go into those. Maybe let the planners talk about their understanding where things are right now. And then proceed with a discussion. There is an option for 'raise hand'; there are two things down at the bottom. You see the little microphone, you can use that to mute, the little camera, it can turn on or off your video. And next to that is closed captions. And because this is Google, it produces very accurate, instantaneous transcription. So if you have any problem, as I do, with hearing, those captions are very helpful. What else? Because without further ado, I'm going to ask the planning team to introduce themselves, starting with Jackie Fishman

**Jackie Fishman**

All right. Thank you, Philip. I appreciate that. Hello to everybody. I know most of the people on the call. I'm sure there's some new people that have joined us tonight. My name is Jackie Fishman. I am the agent on this request for the change to the Balloon Fiesta Park Master Development Plan and the site plan for the stadium. We are here, as you know, as Philip mentioned, we had an early facilitated meeting, I think it was in September, I believe, and then we had a series of meetings after that, that were not facilitated. I personally thought it would be better to have a facilitated meeting for a couple reasons. And that was, one, you'd have more time to speak at the facilitated meeting than you will at EPC. And as Philip explained, we also have another facilitator on the call, Tyson Hummel. You know, whatever, whatever you say is going to be put into the report. And that goes directly to the Planning Commission, as well as it's included in the staff report. We are here tonight because of a mistake in the notification. It was certainly not intentional. No one in their right mind would have done such a thing. It was a mistake; we realized the mistake, and obviously, we asked the LUHO to remand us back to the EPC because it was a mistake that we couldn't overcome. But this gives an opportunity for us to come back to you. We are not doing a big presentation like we did multiple times back in September, October, November. We are here primarily as a listening meeting. And hopefully we have some responses and we can give you some updates on what we've been doing since the hearing in November. With me tonight, Char Johnson is our planner from my office and has been working with me and working on all the notifications we sent out last week. Most importantly, we've got Pete Trevisani, the owner of the team, with us tonight. Also, Ron Patel and Jared Winchester, the project architect – local project architect – is on the call as well, as is David Flores, and he's from obviously Parks and Rec. With that, I'm going to turn it over to Jared. Jared, if you want to say a few words and then maybe Ron or Pete can speak after Jared.

**Jared Winchester**

Sure. Thanks, Jackie. And I'm happy to go back and present any new material for folks who have not looked at any information previously about the project. I'll just sort of leave my initial comments in terms of an update in terms of what's transpired from the meetings that we had last fall, the feedback we've received in information from the appeals document and how we're moving forward to continue to make adjustments to the design that reflect those thoughts and concerns. So, one of the concerns that we've heard, so far as concerns over the height of the stadium, as well as noise. And one of the things we're currently looking at is reducing the height of the stadium to a somewhat lower profile that doesn't put it much more above the height of the escarpment itself. We're looking at better taking advantage of the escarpment – the hillside that is along the boundary where the stadium is sited – which is the basis for how we've located the stadium is to use the siting and planning of the stadium to the greatest extent possible to reduce any sort of fugitive light and sounds to a degree that is acceptable. And so we're also, to that end, looking to lowering the height somewhat of the profile the stadium to also look into maximizing our ability to extend the roof structure and extend the roof over a much wider extent along the west side of the stadium, which particularly impacts the communities west of the Balloon Fiesta Park. We've also been in additional conversations with the sound consultants doing additional analysis of the design and looking into other ways that we can continue to better reduce any sort of sound impact that the stadium would have. So we're looking into additional studies and tests that we can perform to further refine the design. So I'll just sort of stop there as sort of a recap of where we are.

**Philip Crump**

Anything else? And I did fail to introduce Tyson Hummell, who is the director of the ADR program within the city, and administers the land use program. Tyson?

**Tyson Hummell**

Good evening, everyone, I'm sorry we couldn't all meet together all at the same time leading up to this night's event, I'm glad that we're able to all be here and get this hammered out once and for all, as far as really letting the community's voice come through, and also to make sure that you're provided with other accurate information in order to, to move forward and properly contribute. So thank you very much for being here. And I look forward to a healthy, productive meeting.

**Philip Crump**

Okay, thank you, Tyson. So anything else from the planning team? Or from Ron or Pete?

**Ron Patel**

Yeah, yeah. Jared touched on a lot of the specifics. As we've said before, we want to be good neighbors, we've been to a number of meetings, we have been listening, we want to understand the concerns. It helps us as we work through this project. You know, as a reminder, the lease that we signed with the city, it calls for a community benefits agreement, and that feedback that we received from this group will be built into that. And we want to create this in collaboration mode, really. We want to listen to folks that have concerns. And we want we want to work with all constituents. We've said that from the get-go. We mean it. We're going to continue to show up during this process if we move on from the EPC like it happened last time we'll continue to show up and listen and want to work all of the collaborative ways we can into that community benefits agreement. So I'll keep my comments brief. I'm sure we're gonna have questions and concerns. So I'll leave it at that.

**Philip Crump**

Right. Thank you. So many of you were on the previous facilitated meeting back in September and received a copy of the report then. It's my understanding that really the primary issues, and actually they were mentioned by Jared, are light escaping from the stadium, noise impacting the neighbors and traffic. And I don't know whether there are other major issues, if they're new issues that have not been brought up. If people are not familiar with those three primary concerns. Michael Haederle, go ahead.

**Michael Haederle**

So, I'm vice president of the North Edith Corridor Association, and I think an issue we've become a little more cognizant of, and I would love to hear it addressed, has to do with the intensity of the use of the stadium. You know, we're dealing with the soccer team. But this is being advertised by the city as a multi-use stadium, and that definitely means there's more than soccer that's going to happen there. So I think we need to have a clearer idea of what the intensity of the use will be, and I think that's really germane to everything we're talking about. It's one thing to say 17 home games a year, but it's another thing to have a hundred different events throughout the year.

**Philip Crump**

All right, well thank you, Michael. Ron?

**Ron Patel**

Yeah. So look, obviously, the major events – the primary tenant, so to speak, of the stadium – is the soccer team, the men’s or women’s soccer. Is it a multi-use stadium? Yes. It could be used for other events, but there’s a lot of weekends that are taken up by soccer. If you’re going to do an event, it’s traditionally done on a weekend, so you’re not going to – I don’t think you’re going to take a risk on too many events that are not on a weekend. I’m not saying there wouldn’t be mid-week events, but – there’s questions coming that I’ll address after I answer Michael’s question. So, to directly answer your question, we don’t have a full slate of events yet. We’re still in the planning process, not knowing completely everything that’s going to be, that’s in our plan. You know, weather restricts us for months. When I look at these other venues and other in other cities, soccer is the majority of it. It’s not in our business plan to do a lot of non-soccer events. Some, possibly, yes, but I don’t have a schedule, so I’d hate to say a specific number, because I like to be very honest when I speak. If you’re asking for what kind of intensities, how many events outside of soccer, I mean, there’s already events going on at Balloon Fiesta Park, like the Wine Festival. There is obviously youth soccer going on. A lot of that stuff is going to be complimentary use of the stadium. They might want to use the stadium for some of that stuff. Obviously, we’re going to be closed during the Balloon Fiesta for soccer games. We’re not going to play any soccer games during that, but it’s like – it’s there, it’s an amenity to be used to be very complimentary. The city’s going to have a lot of events, too. We don’t know how many events the city will utilize it for. Obviously, they’ve got their own events in the lease, and I feel bad because I can’t give you an exact answer, Michael, because I just honestly don’t know, but that would be my response.

**Michael Haederle**

In your business plan, though, you would have to have some sort of a bottom line, in terms of anticipated revenue, right?

**Ron Patel**

Yeah, we’re building the business plan off of the soccer events. It has to operate with the soccer events. Men’s and women’s – it’s so hard to say, ‘Well, the women’s games have more attendance or less attendance than the men’s.’ Everyone told us that we would have way less attendance than we have right now in the current facility, putting a men’s soccer team in Albuquerque. Obviously, we’ve done well there, with our 10,000 average per game. And what does that mean for those of you that are newer to these meetings, what does that mean in terms of the traffic and the light and the sound? Well, the sample traffic for a Balloon Fiesta day is about 100,000 cars – sorry – 100,000 people, which I believe there’s 13,000 spaces. Jared, correct me if I’m wrong? At the park, we anticipate about 3,000 spaces being used for a 10,000-person event. So obviously, the traffic is much less intense for one of those events. And then the other events, like the Wine Festival is going on, I don’t know what their numbers are, I think they are a couple thousand each day. Basically, divide that by three is the quick and dirty way to kind of calculate how many parking – how many cars are becoming. But another point that I’ve made before, but I’ll make again is the majority – a lot of our fans are season ticket holders, so they have their rhythms. I think what happens at July 4 events and Balloon Fiesta, you get a lot of people that aren’t used to coming to the facility and are coming through the neighborhoods, creating, you know, unsafe issues for the neighbors and for you guys. And so, I don’t think you’ll see that as

much, especially a lot less cars and more people that are used to coming to the facility. Bottom line, it is a private stadium, right? It does need to support itself, because our ownership group is putting the money in. But events can mean a lot of different things. You it could have a quinceañera. You could have a birthday party, right? That's, that's certainly nowhere near the same effect on any of the conditions – traffic, light, sound – as a soccer game. So could there be 100 events in a year? That's a lot but if you had all the birthday parties and quinceañeras, I guess it could be. I'm really nervous to commit to a number.

**Michael Haederle**

Given the size of your investment; you have an obvious incentive to try to maximize the use of the stadium, right? Thirty million dollars is a lot of money, even here in New Mexico, so are you guys open to setting any kind of limitations or boundaries on what you would entertain there? You know, what sort of activities would be off the table because it would just be too disruptive?

**Ron Patel**

Yeah, I think, I think we're open to anything. You know, again, the bigger the event, the more risk there is. So, when you're the ones putting on that event, if you're going to bring in a huge food festival, there's a lot of costs to that, you've got to offset that cost. You not only have to cost the event, but you have the cost of the event production. And so that's not core business, right? Our core business is sports events, soccer games. There could be youth soccer and other sports events in the stadium as well. And that's not going to – there may be a state championship game that draws a few thousand people, but that's not going to draw 10,000 people. The state soccer championships don't draw that. I'm not saying it couldn't, so I don't want to be quoted on that, but those are considerably smaller events. So, I think you're going to see a lot of smaller events. Because even though it is privately built, it is a community asset. We want it to be used for the community. But to your point, yes, it is privately funded and it does need to sustain itself. But the more big events you try to do, the more risk there is, as well. And so if we can do what we do when we know how to do really well. I think that kind of hedges our bets.

**Philip Crump**

There are a couple of questions in chat. Where will parking be situated? Will it be off Tramway?

**Ron Patel**

Yeah, so parking, where the stadium is going to be situated . . . Jared, if you're able to put up a map of the stadium or not? That will help answer the question as I as I walk through it verbally.

**Jared Winchester**

Am I allowed to share?

**Philip Crump**

Yes.

**Ron Patel**

Sorry. Is it OK if I refer directly to Jared, instead of going through you?



**Philip Crump**

Sure.

**Ron Patel**

And as he's pulling it up, so the parking – the stadium is situated in the back corner of the parking lot right now. It's about seven acres. And where you see the stadium situated right there in the red and the dotted lines. It's in the back corner, so our designers have done everything they can to push it back into that corner and utilize that escarpment that is currently like a dirt hill and utilize that area to push it back. Parking will be done – because we don't need anywhere near here the amount of parking that the Balloon Fiesta or July 4 needs, there's enough parking space down there – correct me if I'm wrong, Jared – there are enough parking spaces down here to support, along with a few in the lot that's, I believe, where those little arrows are, where the arrows, where it says Balloon Fiesta. Yeah, right here. Using that lot and all the parking adjacent to the stadium, that's where all the parking goes. Maybe I should just add, Philip, we are in talks, we have talked with some of the larger festival folks that are doing stuff at the Balloon Fiesta park already. Because, again, we said at the start, we want to be collaborative, we want to be good partners, to where if they're having an event that day, they shouldn't have to be paying for soccer parking. Their festival-goers shouldn't have to do that. So, if they're having an event that day, we can work directly with them to make sure it doesn't inconvenience them. If they're already doing an event there, let's make it as convenient as possible for them.

**Jared Winchester**

If I could to just add one thing to that as well, Philip, is that when the traffic is going to be principally using Balloon Fiesta Parkway, which is this thoroughfare here, which is multi-lane. And we have the ability to control the traffic so that it is essentially one way in and one way out, so we can maximize the volume of cars coming in and exiting, coming back the majority of the same way they came, and using the slip ramp, which is now right here, to get back onto the freeway. And we're making every effort to coordinate that so that there isn't traffic flowing through Wildflower community, which is a concern we spoke with that neighborhood and we've heard their concerns. So we're working on optimizing that traffic flow to really – even for cars that are over here in that upper lot – to utilize San Diego and San Mateo to get in and out, so that they're not coming from the south through Wildflower. And that, that was some things that we talked through in some of the earlier meetings.

**Philip Crump**

Another question: Was the business plan disclosed to the city in this planning process?

**Ron Patel**

So the question was, was the business plan disclosed to the city?

**Philip Crump**

Yeah. Disclosed to the city.

**Ron Patel**

I think we had a plan? Jared, do you know, the answer to that? Or maybe someone from the city? We've stated the use case for a facility INDISTINCT we had in the facility we have now. But I'd have to get back to you on that. I don't want commit to say yes, for sure. I wasn't the one that sent it. So –

**Philip Crump**

I guess the question is, is the business plan part of the application or not?

**Jackie Fishman**

Philip, maybe I could answer one part of that question. It was not part of our EPC submittal and will not be part of the remand hearing.

**Brooke Jordy**

Mr. Crump, that was my question, if I could just explain it.

**Philip Crump**

Sure, go ahead.

**Brooke Jordy**

At any point during this process, leading up to or as part of, or since the initial EPC hearing, was that business plan disclosed?

**Ron Patel**

I'm not certain that it was. Jackie, do you know?

**Jackie Fishman**

Now, again, not, not, not through the planning process. I don't know if it was provided when the City Council was looking at the lease. I wasn't part of that, that process of the land use planning process.

**Ron Patel**

And I think because it's a, it's a private business plan and a lot of business is not tied to the stadium. I think that could be the reason why it wasn't required.

**Brooke Jordy**

If it was disclosed, I would want to have it turned it over to the neighbors, either way. But if it was disclosed, then we do have the right to access that through public records. If it was disclosed to the city, whether or not it was for EPC. So I would just request that we receive that.

**Ron Patel**

I think you're absolutely right, Brooke, if it was submitted to the city, it would be public record, but I don't believe it was submitted. I guess – Brooke, do you represent all the neighbors? I just want to be certain about that. So whoever it is you represent, what would those people like to see, I guess is what I'd like to know.

**Brooke Jordy**

Well, I don't represent anyone, but I am one of the neighbors and one of the appellants. And the neighbors who are opposing, which is the vast majority of people who live around the park, oppose the stadium. I think there's like at least 70 of us who at least signed on to the appeal, but there are others who have expressed recently their willingness to sign on in opposition. And the reason I'm asking is because, if you are basing, if United is basing their representations to us on aspects of their business plan, I would like to see the written business plan. Because some of those things would be, I think, better stated in writing than just verbalized here. So, you know, if that's something that you're basing these sorts of future stadium uses on, it's pertinent to what Mr. Haederle was speaking about.

**Philip Crump**

Well, I guess that's a question that Ron, as owner, one of the owners, of a private business, whether that's something that you would do, or some portion of that information to be available to neighbors.

**Ron Patel**

I'd have to talk to the ownership group. I'm the president of the club. I'm not one of the owners. I could present to the ownership group and say that's the request. What, I mean, would it be a private business plan, what might be better is trying to understand – when we talked about the intensity of usage? – what are the things that the neighbors are looking for? Maybe some checks and balances or some – we're not trying to hide anything. It's private business. And we're still trying to be, we're still trying to understand the full scope of the stadium as we, as we build it, and trying to understand what level of it – we still don't fully know what level of intensity you would have. And that's what we can't really give a direct answer.

**Philip Crump**

So, here's a possibility – that you discuss it with the owners. Yeah, I understand the question is about intensity of use. And to the extent that you can provide that information, send it to me and I will forward it to everyone for whom I have an address.

**Ron Patel**

Yeah, I guess only other thing I would say, Philip, is maybe if we're looking to put some things in the community benefits agreement is what are some of the things that the neighbors would want to see in that as it pertains to intensity, and that could be another way of going about it, as well.

**Philip Crump**

OK. So let's hold on to that for just a second. There was a question about, from Tina Villegas, could multiple events be held on the same day at the same time?

**Ron Patel**

I guess being because Balloon Fiesta Park is a facility itself, yes. You could have youth soccer going on. It's 400 acres. You can have stuff going on at Balloon Fiesta Park on the same day as a game. Yes. It probably wouldn't make much sense to have two events going on at the same time, although it could. But right now, I know, like, I've been out there for festivals and stuff like that, and they've had three or four different events going on at the same time on different – I think they have parcels of grass – and

there are multiple events going on at the same time. Yeah, we had a wine festival going on at the same time as a fundraiser for someone else. So I think that happens already.

**Philip Crump**

All right. Thank you. Leslie Linthicum, you've been very patiently waiting.

**Leslie Linthicum**

Sure. I had, I just have clarification, Ron. Did you say the number 100 when you were talking about intensity of use? Mas o menos, 100 days?

**Ron Patel**

I think I was referencing a question that was asked of me. I think it was Michael that it asked if it was 100. So I was referencing the number he threw out there. That wasn't my number.

**Leslie Linthicum**

Okay, so you're not committing to that, or spit-balling that?

**Ron Patel**

No. I was just addressing one of the questions that was asked me: Would you do 100 events?

**Leslie Linthicum**

And to your point about the size of events, you talked about, you know, a birthday party or a quinceañera. From my perspective, sitting immediately west of the park and hearing every pin drop over there, it doesn't really matter what the size of the event is. It's about amplification. And so, the Golf Center has numerous weddings and quinceañeras. And as soon as the band starts up, my life is changed. So if, you know, if you're thinking about it in that way, I'd like to just ask you to think about amplification, not how many people are at an event.

**Ron Patel**

Yeah, I hear you loud and clear. And please note that a lot of these events would be indoors, because we have a clubhouse area, so those could be indoors. And when I'm referring to the number of cars, I'm not referring to the sound concern, I'm referring to the traffic concern, saying that not every event is going to be 10,000 people like at a soccer game, where there will be a lot of cars within the neighborhood. So there's multiple concerns that have been raised and I'm trying to address as many as possible. But yeah, I do hear you loud and clear. And again, I think Jared touched on it a little bit before. We're working with the sound engineers to understand what can be done to be directing the sound in the right way. And not having an – because right now if an event happens on the grass at Balloon Fiesta Park, it just, it sounds like you're right in, it's going to hit you first. And it goes right out there. There's nothing to block that. What we're working to do is figure out how do we engineer it properly, where the sound stays that way and goes, pushes north where there's no residences,

**Leslie Linthicum**

Mr. Crump? When is the appropriate time to drill down into the details of these potential changes to the building that were introduced at the beginning of this meeting and learn more about those?

**Philip Crump**

Well, we've got a couple of issues on the table right now. There's still some questions in the chat about parking. I think if we can get those answered, any of the questions about intensity of use? And then talk about changes to the building? That seems OK.

**Leslie Linthicum**

Sure. I just kind of want to make the point that we're talking about details. When I – I'll speak for myself, but I think that, you know, 70 neighbors who are part of this – our basic point of view on this is that we don't want it at all in our neighborhood. And I just want to be very clear about that. And have that on your record.

**Philip Crump**

OK, good. So just another question about parking, and whether there will be control of traffic to prevent parking in the adjacent neighborhoods.

**Ron Patel**

Yeah, so let me address that a few different ways. So, and forgive me, for those of you that have heard this before. It just bears repeating that when we have a game going on, and we communicate to our fans, all of our fans buy their tickets through the Seat Geek website app. And so they provide their email address when they buy a ticket. And so we communicate to them before the game with an email that tells them – so, you've got roughly about half a stadium right now, season ticket holders. The other half or third is people that have bought from the group and then the other third is people who just bought individual tickets. And so we communicate to all those people, you know, it's game day that these are things to know. Like, at Isotopes Park where we play now, has a clear bag policy. That's one of the biggest things we have to communicate. If you've ever been to an event and you've seen a clear bag policy, it can be a pain in the butt. You have to remember to leave any bags in the car or only bring them in in the clear bags. So we communicate that. We also talk about any closures of parking lots. Near Isotopes Park, it happens all the time. There's not really an issue with traffic there, because it's really only a couple of roads you can take in, but that's how we would utilize the communication platforms we have to address this question is communicating the traffic plan in. And then assisting with that would be the barricades we put up at the key entrances. This is more directed for the Wildflower neighborhood that had brought these concerns to us originally, talking about how during Balloon Fiesta lot of people cut through. There was conversations with the city, and I think, I don't want to speak on behalf of the city, but I know they were entertaining the idea of speed bumps in the Wildflower neighborhood because of this issue. It's been raised to them before the July 4 events, with Balloon Fiesta events. But again, it's not my place to speak on behalf of the city there. And then, so, communication is key with that, with the traffic plan and bringing folks in. But keeping in mind that most people will have their routine, with season ticket holders. And so there's not going to be a need for parking spaces far away like there is for Balloon Fiesta, just because there's so many fewer cars. Does that answer the question, Philip?

**Philip Crump**

So, one, you've got plenty of parking, and two, the possibility of barricades, and three, communication with ticket holders to encourage them to use the north access.

**Ron Patel**

Yeah. So, like with our agreement with the Isotopes now, we already employ police officers and traffic control folks. And that'll be the same as we've said in multiple meetings that we would do that to help mitigate some of those traffic concerns getting into the stadium.

**Philip Crump**

OK. All right. Anything else about intensity of use? OK, Tina, you're up.

**Tina Villegas**

Yes. Hi, there. Mr. Patel, you keep mentioning in the lease there's a mention about the community benefits program. But all that's mentioned in the lease, is it just says, "Tenant agrees to develop a community benefits program." Can you possibly elaborate on that and give us more information what that would look like? I mean, what kind of avenues we might have? You say you want to work with us. You've been saying that you want to work with us. But I have yet to sit down face to face with you and talk about any issues that I have. And I am pretty much the closest one to this new stadium.

**Ron Patel**

Yeah, so the community benefits agreement – and I'm always happy to sit down face to face. So if that's what the next step is, Tina, we'd love to do it and listen and understand. So, Mr. Hauser had reached out at one point to ask to sit down. I said, yes, let's find a date. He's had some other stuff going on and he hasn't been able to, but happy to do so. In terms of the community benefits agreement, I don't know if someone else can speak more specifics, not my area of expertise as to what community benefits agreement is. I can tell you my understanding of it, but I'd rather have an expert explain what it is. And then I can tell you how we plan to utilize that to work with you. So, I don't know if that would be someone from the city, Jackie, someone from Improve Group, I'm not sure if someone else has a better understanding of that.

**Philip Crump**

So, who's familiar with the community benefits program?

**Tyson Hummell**

I could take a stab at it. So, a lot of the time when there's a city applicant, or in this case, the city-adjacent applicant, there's concern in the community that to the extent that, you know, any kind of community resources might be used in the furtherance or establishment of the project, that the overall effort is going to be a net benefit to the community. It's usually not a forensic breakdown analysis of contractual rights and obligations. Rather, it's an aspirational, broad strokes type of agreement with some specificity in there to support things that are needed. The most recent example I can point out would be the Rail Trail project, which was a community walking and recreational trails to link up the Railyards area, the Sawmill, all the way down to the to the bosque. So, I know it's little bit vague and ambiguous, but so are the community benefits agreements, to be honest with you.



**Tina Villegas**

I guess I'm just unsure what a community benefit program was. I just assumed it would be when the neighborhoods have issues, you know, how do we respond? Like when you do have noise or lighting or traffic or things of that nature, how will that be resolved? You know, on the night of the game when it's too loud, I know you can't tell like 10,000 people to be quiet. They have paid their admission to get into a game and they want to cheer and be loud. It's just that for the neighbors, especially myself, I'm just concerned that whether you put a roof or partial roof or no roof, it may not contain all the noise and what would be my avenue to, I don't know, report it? You know, it's just scary when it's so ambiguous to us that we have no idea what you mean.

**Ron Patel**

Yeah, I totally understand where you're coming from. Jared, I don't know if you can speak again, to sound, a little bit. I don't have all those answers for you right now, just to be frank, Tina. This is where we want to sit down and talk and listen, and understand and come up with what that process would look like. I think a lot of it comes in the way that we engineer the project, though, and to, to hopefully there wouldn't be those concerns. We totally get it. We totally get that something, if you don't understand it, can be scary. So, I hear where you're coming from, 100%, We want to work through it. And we want to be factual about it and not be speculative. We want listen, understand, and then try to figure out how we can we can make it work.

**Philip Crump**

So Tina brings up a question about if there's a concern at the time what are her recourses.

**Ron Patel**

Yeah, so the way that it works, I think right now, for city events at Balloon Fiesta Park, I think there's a person they can call. What we've committed to do is have someone on staff, I think someone should present as a liaison. So, I think what we verbally committed doing, and this is something we'll probably put in the community benefits agreement and communicate out with all of you and the organizations – is someone on our staff you would communicate directly with. I think it seems like that makes the most sense. But again, sitting down and listening and talking about what that looks like, if that's the best way to go, then that would make sense.

**Tina Villegas**

Because we have that process now with the city, when they do have events that are too loud, we do call, but not much gets done right away, that evening. They keep telling us that they're going to work on the noise and watch the decibel level to meet the sound ordinance and things like that. Will you be, will you be meeting that? You know, will you be monitoring during your games? Or, you know, so that you will know that you're out of the ordinance or not complying with the ordinance? You know, it's just stuff like that.

**Ron Patel**

Yeah, I think I'll defer to Jared, again, with the process of how we're going about the sound studies and making sure, you know, we do plan on monitoring. Jared you can speak to more about – a lot of this comes to how we design, right?

**Philip Crump**

It seems like this is an operational consideration. So . . .

**Ron Patel**

Yes, and the direct answer is we plan on having a liaison like the city does with Balloon Fiesta, someone you can reach out to. But I think that the way to truly get ahead of it is to design it the right way. Because right now anything that happens on that field, it just plows into your living rooms, right? And that's not the way we want this to work. We want it to be designed where the sound can be mitigated as much as possible. I'll let the experts speak to what that means in terms of decibels and exact numbers, because that's not my area of expertise.

**Jared Winchester**

The max decibel level that we used for the stadium design is based off of what is even a probably greater-than-possible decibel level for a crowd. So crowd noise is one thing, and to a great extent we've buffered that sound. Amplified sound is a different thing. So amplified sound has to be cut off and monitored at certain levels. And the team will be fully able to work out the sound system such that the sound is distributed, meaning that we don't need a really loud sound source to reach the ears of everybody because we have a distributed set of speakers throughout, so that the sound is lower overall. The sound will be emanating principally from the west side towards the east/northeast. So that it is, again, directing that sound in a direction that will have the least impact to the neighborhoods while also using a distributed system. So we're trying to use the acoustic system to the greatest extent possible, minimize the source of the sound. Then we're using the positioning of the stadium and the massing on the west, which is the only side where we have to use building mass to block it, and roof between the massing of the structure and the roof to block that sound. Now, on any other event, when there's amplified sound, that sound will have to be kept to that 90-decibel limit. And there's mechanisms to make that a part of the deal for any event going on at the stadium. And that's an important thing, not just for staying within the noise ordinances, but even with fire safety. You can't have some concert venue with noise so loud that it drowns out the fire alarm. So you have to maintain, you have to ensure that that decibel level isn't, with amplified sound, going up above that, that threshold, either. So there's a lot of operational parts to how sound is employed during any event to make sure that the noise is not becoming excessive.

**Philip Crump**

And that 90-decibel level is measured where?

**Jared Winchester**

Meaning where do we measure it from the from? From the center of the of the stadium, essentially.

**Philip Crump**

So that's 90 decibels within the stadium.

**Jared Winchester**

Within the stadium, yes. And that's maximum.

**Ron Patel**

If I can make another point as well, I think the key word is the buffering, here. So, much like we talked about the Balloon Fiesta having an event and there's 100,000 people, there's a lot more intensity of traffic. Right now, the intensity of sound, for any event that happen within Balloon Fiesta Park, just goes straight into the neighbors. And a lot, I've been at events where the stage is being utilized and the sound is going that way, that obviously is not comfortable. And so, with this, with the way that it's being designed and the buffering that's there, even if it wasn't designed that way, there's way more buffer than there is for a typical event on the field at Balloon Fiesta. And then with the whole engineering part, that's the way we're kind of working through these things, and I'll leave it to the sounds experts to explain how that works.

**Philip Crump**

OK, thank you. So, Maggie Rose has had her hand raised and is getting tired of having your hand raised. Unmute your mike and tell us what's on your mind, Maggie. You're muted. Can't hear a word. Unmute your mic. We can't hear a thing, Maggie.

**Leslie Linthicum**

Maggie, click on the little red microphone at the bottom of your screen.

**Philip Crump**

Do you see the microphone at the bottom of your screen, Maggie?

**Maggie Rose**

OK, I got it now.

**Pat Hauser**

Now you can start over, Maggie.

**Maggie Rose**

Oh, hallelujah! This is not a way for an old person like me to meet. I like to meet in person and, you know, talk about things and mediate and get together and how we can solve problems and work together. And I am not a technological person, as you just observed.

**Philip Crump**

You seem to have it working just fine. Thank you.

**Maggie Rose**

I'm the president of the Maria Diers Neighborhood Association. And I've lived out here 48 years. And I'm adamantly opposed to having the soccer stadium go on the balloon field for many, many reasons. But the huge part that I'm opposed of it for is the devastating effect that it's going to have on our neighborhood. I mean, we live out here in darkness. We love our night skies, We have a rural area. I was working in my yard this morning and it was so quiet and the geese flew over – it's a wonderful way of life. And on the weekends, I hear the kids playing soccer over on the balloon field. And I hear them

clapping and the whistle, and it's sweet and it's wonderful. I love kids. It's all cool. But I think about 10,000 fans doing that and I think, Oh, my God! I'm involved in this because I care about my neighborhood. And none of you live here. So you really don't care whether you ruin our neighborhood. I just, I feel like a hurricane is coming at us. And I don't know how to get prepared for it. But there's been no real effort to try to work with us. I mean, we're willing to sit down and talk to you. To me, this is not working together. It doesn't work for me. I'm old. And I'd rather have a meeting and get together. And so I have some questions: Because of the sound and the noise and the lights, are you willing to put a roof on that stadium? Will United limit the amount of concerts they have? Will you agree to turn the lights off at a certain time? We like our night skies out here, if I hadn't mentioned that, will you prohibit fireworks and those air horns? And I would just like for us to have a meeting, like in person. Could we do that? And talk? I'm willing to do that. But I'm deeply concerned about how this, the process, about how this is going down. OK, thank you.

### **Ron Patel**

The answer is yes. And we've said that from the get-go. Again, there's a lot of different organizations represented here. So whoever wants to meet – whether that's as a group, whether that's one-on-one – you let us know. I'll put my email in the chat. And please let us know when you're available, and we'll meet. I know we don't live in your neighborhood. But we are Albuquerque and New Mexico residents as well, and so this is not, we're not here to hide anything. We're not here to, just you know, check boxes. We've been to seven meetings in person that we didn't have to go to and we're gonna continue to go to them.

### **Philip Crump**

Thank you. Sarah Shortle, you've also had your hand up a long time. She seems to have disappeared. That's the wrong button. Well, we'll wait. We'll let her in later. Amanda. You've been waiting also.

### **Christine Benavidez**

Okay, hello, my name is Christine Benavidez. I'm using my daughter's computer – her name is Amanda. So anyway, my question is, has anybody done a study on the Albuquerque box? The Albuquerque box is very famous with the Balloon Fiesta, where the balloon's going up in the little square because of the wind and the currents and the flow of the air off the mountains. Well, I know the Albuquerque box also carries all the decibels through our neighborhood when the Albuquerque box is in effect. Not only does it bring the wind, but it also brings the noise and it keeps going in a square, in a square. Has anybody done a study about that? I guess this question would be for Jared Winchester, since he said that the sound consultants were doing investigations and all this other stuff. So I'd like Mr. Winchester to answer my question about the Albuquerque box. And guess how I know it works? Because I live in it. I know how the Albuquerque box works. Great for balloons, not good for noise. I'd like to have a study done on that.

### **Philip Crump**

All right. Jared?

### **Jared Winchester**

So one of the things we're looking into is doing a sound test, a live sound test, to get the environmental readouts of how the sound is traveling, so that we can put a kind of control to the computer modeling, because we understand that it's very geographically and environmentally specific, the way the sound travels. So the sound consultant, Anthony James Partners, is putting together a scope for conducting that work. Essentially, we would create a demo peak sound and we would have monitoring devices around the edges of the neighborhoods. And we would be able to check without the benefit of any stadium to buffer it but just to test the environmental effects of how that sound dissipates.

### **Christine Benavidez**

So no, you haven't done a study about the box, the Albuquerque box – that hasn't come into effect. This certain part of town. This only happens here. This isn't in the Northeast, Southeast, none of that. This is here in this North Valley. So I want to know if the study can be done prior to anything being built. Because we're the ones that have to hear all this decibel levels. We're the ones that get pounded. And we live in the Albuquerque box. So I would appreciate it, if they would check into that, because we can't even go outside when this noise is happening. And if that stadium is coming in, and it's going to have all these events and all this other stuff that they're going to have, yes, I want to know how the Albuquerque box is going to affect it decibel-wise. And it doesn't happen all the time. It's a certain time when the warm air comes up off of the mountains. And it's usually in the evening and early morning. So I would really like a study done by your consultants to figure out how this is going to affect our neighborhood before you even put that stadium up. We are the ones that have to live here. Nobody lives in the box but the people that live in the box. So please, that would be great.

### **Philip Crump**

OK, Jared, you got it. Sarah Shortle, welcome. Let's try again.

### **Sarah Shortle**

Sorry about that. It was a red box, you know, so I clicked on it. I want to start by saying I'm fully opposed. And I want my vote to be counted. And there are reasons, a lot of them. But you know, primarily the usual, the light pollution, the stadium might be visible from our homes. I know from Tina's home, it probably will be, and several others. And that's important, because of our view of the mountains. We are gifted, it's so lucky to see those mountains. There's noise pollution. We already deal with that. But we worked things out so well with the Balloon Fiesta. The city has not been a major participant in working with us, and that's too bad. And I'm sure we can improve those things if they ever pay attention. But we're not in the city. So you know, we don't vote and I guess they could care less about us. And so from what I've heard about watching soccer, there is noise. And there are air horns and things. And we already know there are – with other things, other events – there are fireworks, and there is traffic. So there's multiple considerations regarding the monitoring and governing. And these things. I have seen the lease and the lease is not adequate. I hope somebody wants to go back, because we are so willing to work with you if – I'm sorry – you, as in the soccer people, if we can address some of these, so we don't see limitations on some of this stuff. Certainly not in the lease. There's nothing specified about a lot of our complaints. Another reason it's so important is that the soccer stadium is not in harmony with our neighborhood, which is completely rural, small farms and livestock. And Alameda is a very old community. Very old, so we are historic, we're in land grants. There's a lot of things about Alameda that are important. And there's nothing in anybody's view of the

community of Alameda that includes a soccer stadium. Other considerations: why not look to other areas? I've asked Ron that. Alameda, as I said, is an historic rural community. Why are we going to change it? There are places like where you're currently practicing – Mesa Del Sol. There's also areas off the Rio Puerco. There are places that are close to I-40 that allow people to access without ruining a community. There is Rio Rancho, which is a crime-free community, which is lauded all the time about one of the best places to live. Find a place in my lifetime, that's been a lot of sand dunes that are growing, and it's huge. And there are places between along the whole area between Bernalillo and the highway there and the Rio Puerco. There are places. Next, I would say there should be better collaboration with the affected community, particularly in rewriting the lease. That lease sucks, I'm sorry. Inasmuch as I am against it as it is proposed, I can see that some changes would lessen the impact to this neighborhood, this area, that would make it acceptable to me, and I'm sure to many the people who live here. Put a lid on it. A roof would eliminate the noise of fireworks, those kinds of concerns. They're huge, those concerns, you should see the dogs and the animals when those fireworks are going off. Any lighting outside of a roof should be directed away from the neighbors. And we've talked about that. But I haven't, you know, the lease does not say that. There's nothing in what we're talking about that actually says that anybody's bound to these conversations. Another thing would be to eliminate alcohol sales. This area does have a history of people drinking and driving, this is Albuquerque. This is this is a place where that is a concern. We're trying to eliminate it, improve it. So let's eliminate alcohol concerns. Finally, really, a better collaboration with the affected communities. I mean, yes, I've met Ron, I've met other people. But when we talk, it's them standing up there listening to this. There's not a roundtable discussion, where we can meet and discuss and say, 'Let's work these things out. What are we going to do about the lighting? What are we going to do about these things?' It's Ron trying to defend his, I guess, his boss. Trying to defend that, where it's not collaborative, and we need to make it collaborative. Otherwise, we are left out in the cold. All right. That's my two minutes. Thank you.

**Philip Crump**

Thank you, Sarah.

**Ron Patel**

Am I permitted to respond, sir? Obviously, there's a lot there, Sarah, so thank you. And thank you for letting me know about the lighting above me here that you couldn't see me earlier. I appreciate that. A lot to unpack. There are a couple of things I want to address. So one, if fireworks is a concern, and it sounds like it is, it's an issue we want to discuss, right? So we'd be, we'd be open to limiting it. And we want to sit down and talk about that and all the other issues we talked about as well. As I believe I mentioned to Maggie earlier, we're open to sit down around a table to discuss. Again, we're trying to do the best we can to meet with everyone that's involved in this, different organizations. So we have to figure out the method and the format to do that. But we're not hiding anywhere. We're totally open to that discussing the fireworks, the other issues. In terms of the blocking of the view, the lighting, I think, Jared, if you could help address some of those for me real quick. It's not my expertise, but I will tell you, first of all the lighting, I know that with the technology these days, there is 0% light pollution. And I think we showed a picture of that in one of the community meetings. I'm not sure if you were there, Sarah, but Jared, if you could talk about the lighting, the view of the mountains And I'm just checking my notes here. The moral of my response, Sarah is, yes, we are open to compromise, and let's, let's collaborate.



Let's talk about the issues. But Jared, if you could just address those to the blocking of the mountains and lighting to start and then we'll go from there.

### **Jared Winchester**

The lights are not going to be directed to the west. The light fixtures that we have are directed straight down to the field, and those light fixtures have shields like large eyelashes that are directing the light just at an angle that's hitting the field. And that contains all the, all the illumination to just within the stadium. Now, so it's not one of those big broadcasts, you know, lights just projecting outwards. So the technology for those lights is something that's a part of the design that we've worked out. And the company that we've worked with, works with a lot of dark skies communities for many types of facilities that have a need for light fixtures, even within dark skies communities. So they're very sensitive to that need of containing light and the types of fixtures of a level of quality that they're going to be able to keep any fugitive light. The examples that we've shown so far, and I can share it again, are the Colorado Springs Switchbacks stadium, which is a good lighting example. I can just share my screen really quick here. So that's the view from the side, and from top down. You're seeing how that illumination is 99% contained within and beyond 10 to 20 feet, there is no surfaces illumination. If we go back to the light fixtures themselves, so why aren't we seeing a hotspot in these, if you zoom in on that. All these fixtures, even though – when we're looking at these, all these fixtures are directed straight down at the field. So those elements are allowed allowing us to contain the light, such that you're not going to pick up a hotspot from the surrounding neighborhoods. I'll stop it at that. But that in an essence is the design strategy we're trying to take. Now, from the west elevation of the stadium itself, we're going to make sure there's no building-mounted lights that are projecting out either. We don't want the west side of the stadium itself to be shining out. So again, we're looking at that elevation and everything that's directed towards the west, to reduce that from being something that's some type of a, you know, a distracting light beacon at night that you don't want. The other thing to consider is that the games end, generally right at 9. So, at some point, we're going to be able to turn the lights off not too long after that, as well, entirely. Or drop those lights. I think, Ron, after a game concludes the illumination levels on the field lights dropped considerably, don't they? They're still on slightly, but we can drop those a little bit.

### **Ron Patel**

At Isotopes Park, where we are right now, they're way older than the lights – the newer lightning technologies. So the one we use right now aren't the same.

### **Philip Crump**

And Jared, there was a question that was raised about lights in the parking area.

### **Jared Winchester**

We're not having light poles in the parking area. We're having low pedestrian lights, like light bollards, those types of functional pedestrian lights. But we're not putting in the, for instance, the parking lot to the north of the stadium, we're not putting all light poles, those types of things, if that's a concern. Like what Presbyterian has on the top of their parking lot, the Cooper building.

### **Jackie Fishman**

So today, can I interrupt just a second? I think Pat has had his hand up for a long time. If you could call on him, I'd appreciate it.

**Philip Crump**

Well, he's next up. OK, Pat

**Pat Hauser**

Let's see if I can get the right buttons pushed here at the right time. I just want to start off is that my wife and I have lived in this community for 57 years. So we lived in this community longer than a lot of people that are on this call have been alive. So we've seen the community, which used to be the East Mesa, was turned into a city dump, which is the Nazareth dump, and it's now covered up but it's still emitting gases and things like that. And so we saw that turned into a gravel pit and that gravel pit is now turned into Balloon Fiesta Park. So with that being said, and I'll start and kind of work backwards on this stuff. Is that is the fact-based reality, Sylvia and I would like to go on record that – and as well as the adjacent property owners, that we are opposed to the proposed multi-use stadium, as well as the process that's been disguised by the city and United Mexico as a soccer facility, that's been disguised, it's been talked about many, many times. This is far from reality. Just a quick notice that we were given three business days' notice to have this meeting, and as an operations person for a large company, you should typically give a minimum of 14 days or 30 days' notice for a meeting. That same situation is going to confront us when we have the EPC meeting. Once again, short period of time to be able to respond to this. And it seems that this meeting is another rush and push to get this meeting completed so the applicants can check a box. There's been a complete lack of virtue by Consensus Planning the city, United New Mexico. They seem to view this as a technical step and not a listen to the surrounding communities that this will have a devastating impact on. As a neighborhood associate vice president, I can of the majority of the residents being opposed to this stadium as well. We are opposed to the use of Balloon Fiesta Park for the as a location for such a multi-use stadium, and [it] will have extensive and negative impact on our lives and properties as other well surrounding communities for decades to come. And that's 30 plus, it goes up to 60 years. There's been historical research in the Balloon master plan that clearly states that building a stadium as proposed would not be done as outlined in the master plan. We've gone around the master plan, we're trying to rewrite it and do those things on a "let's pick the cherries and make those things happen" It was said in a comment, "The original stadium proposed was voted down 2-to-1 by the city residents." What now is happening is a product of mistruths, misinformation for personal political and financial gain by the secret actions of this administration in conjunction with United New Mexico. And in response to Jared's comments, I'm gonna back my train up, because during the early 60s, I worked at the Nevada Test Site. We used Cray super computers at Los Alamos to simulate projected outcomes. I feel confident that the computing systems at LANL were much superior to Improve Groups or anybody else that's going to be able to do this. Not until we look perform this specific real-time activity was the outcome known. Those proposed simulations on sound and lighting, are at best frail predictions as to what will be impacting the real noise and lighting levels of our neighborhoods. The referenced stadium in Colorado Springs was put where an old steel mill was at in Colorado Springs. So it isn't a dilapidated downed area, it sits down low, it doesn't sit up, the way this stadium will do. One of my longtime friends I went to grade school with in Colorado Springs, he says, "When they turn the lights on, I can mow my lawn in my backyard." So I guess I take issue with what's being said on these light things. So once again, I think that the proposed stadium is being forced on the

surrounding property owners by persons, people and organizations that don't live within miles of the site, and they don't even live in the city. Such as, for instance, Mr. Trevisani, who lives in Santa Fe, and I am confident he would not be in favor of such a multi-use stadium in his backyard. So there are just a number of things that go on with this that don't fit with this community, and don't fit with those of us that are longtime residents here. And I will yield for any other questions.

**Philip Crump**

Thank you, Pat.

**Ron Patel**

Yeah, a couple of responses, I think, Philip. When you when you say that we are trying to rush it or check a box, even Pat, you've been telling us we've been trying to rush it for months now. We continue to show up to meetings, not required meetings. I've had email interactions with you. I can show them to anyone that wants to see them, trying to meet with you. You've not given us time to meet. I understand you have stuff going on, but it's not due to us not trying. In terms of the – there was another point made about rushing. The point escaped my mind now, sorry, it's been a long day. So I just wanted to point that out. We've been overly communicative about wanting to meet. And like we said just a minute ago, let us know when we can sit down and chat about the issues. and we can talk them through.

**Philip Crump**

Steve Wentworth, and then Michael

**Brooke Jordy**

I'm sorry Mr. Crump, I just wanted to follow up on that because it's been deflected a number of times. I thought we were meeting to discuss the issues tonight. And now Mr. Patel has said a few times that he will in the future meet with us to discuss the issues. So I just want to clarify that.

**Ron Patel**

I've been asked multiple times if we can meet in person and the answer is yes. So, there you go. Yes.

**Steve Wentworth**

Hi, I think it was brought up by Maggie Rose, Pat Hauser, and so forth, and I know I sent a letter to Jackie Fishman, as did many others about postponing this meeting. This meeting three days' notice is not adequate. And Mr. Patel talks about collaboration working with us. The request to postpone this meeting to a later day, was flat ignored, flat ignored That's not collaboration, that's not working with the community. Our requests to postpone this out a week or so, were ignored. Now we have an EPC meeting coming up, and we're going to have to deal with that. So, I wanted to state that. I wanted to also ask Philip if you got a letter from Sandy Zuschlag, who wanted that included. She's out of the country right now. And I also wanted to know if the recording of this meeting will be available to the public.

**Philip Crump**

The recording will not be available to anyone.

**Steve Wentworth**

Why?

**Philip Crump**

I use it only for my own purposes to help create the report. I have never released any of the recordings of the any of the meetings I've conducted.

**Steve Wentworth**

How about the transcript of the meeting?

**Philip Crump**

No transcript. You get the report of the issues and responses.

**Steve Wentworth**

I think that sucks. It's not transparent, it's not democratic, and so forth. I'm sorry to hear that from you, Mr. Crump. If the meeting's being recorded, the public should have the ability to get a copy of this meeting that's being called as a facilitated meeting with the City of Albuquerque. We're citizens, and so forth. And the citizens should get that. I don't particularly live in the city, but I pay a lot of damn city taxes. So that's very sad to hear, sir. The letter from Sandy Zuschlag, did you receive that?

**Philip Crump**

I've received a lot of emails. I've received a number from Sandy.

**Steve Wentworth**

Today, today. All right, we'll wait on that. I wanted to comment that you should have received that, and we'll make sure it gets sent to the city to be included in the record.

**Philip Crump**

I include in the report anything that was involved in this meeting itself. She can submit that to the EPC, to the staff, as the proper approach. Anything that was not presented in the meeting itself should be presented separately, and the report will have instructions on how to do that.

**Steve Wentworth**

OK, thank you. We'll try to make sure that it gets included. People brought up, Ms. Shortle and so forth, about the lease issues. Absolute agreement, the lease is vague, it's simplistic, it sucks. It's 14 pages of almost nothing, almost written by United Soccer for their uses, not by the City of Albuquerque to protect their property or to protect the community. That lease is ridiculous. My question to Mr. Patel, are you open to amending that lease and reworking that lease, so it protects the people from the sound issues? You can turn down the volume on an amplifier, you can't turn it down on the noise makers and crowd sounds. Do you need to include a prohibition on alcohol sales, on x number of concerts per year on all sorts of other items that could go a long ways to protect the surrounding community? Are you open to that, sir?

**Ron Patel**

As I said earlier, Mr. Wentworth, we're open to listening to all of your concerns, and yes, ready to meet in person, on Zoom? How –

**Steve Wentworth**

Are you all amending the lease before the City Council to address the concerns?

**Ron Patel**

We are open to listening to all your concerns and figure out how we can protect those concerns, yes.

**Steve Wentworth**

You didn't answer my question, Ron, but what else is new? The business plan question goes to this whole lease issue. I can't understand why the city, under supposed due diligence, wouldn't want a business plan in front of them so they would know what they're signing a lease for. It's beyond absurd why that wasn't done.

**Philip Crump**

The lease, you would like to see the lease amended.

**Steve Wentworth**

Yes, absolutely. Also to make sure it's on the record that ANVA and two other neighborhood associations, and 70-plus people, Mr. Crump, oppose the stadium. Others have mentioned that several times. So we want to make sure you have that in your report that it is opposed. We brought this up at the original meeting that the Balloon Fiesta Park Commission prohibited in the Master Plan, stadiums. And now we see that the city, for some inexplicable reason, has gotten together with Parks and Recreation and are lying about how that prohibition came about. I served on that commission. I was part of the master plan process for both of them. And that prohibition was put in for very good reasons, sound reasons, It shouldn't be amended by some agent for the City of Albuquerque, or somebody from Parks and Recreation who weren't part of the process. It was there for a good reason, and we tried to enumerate that in our information to the EPC. Concerts being limited and other types of uses. You danced around that, Mr. Patel. The community is very concerned about that. If you've had uses out there that aren't enumerated or prohibited or spelled out in the lease, what control, what protections do we have? You know, we've had concerts out at that park where they've served alcohol, where they're conflicted with other uses of the park, and they've been a damn disaster, a disaster. As pointed out by the residents. Balloon Fiesta does a good job of trying to work with the residents and addressing sound issues and so forth. City Parks and Recreation do a terrible job, a terrible job. They've never been able to address the issues correctly since they started. And they don't really give a damn about the neighbors. They don't address them. There is a noise ordinance that the city refuses to enforce. Are you going to get current code enforcement out at the stadium after five o'clock, when all the enforcement officials from the city have left and gone home? I doubt it. So the neighbors suffer from this. And Mr. Winchester, your sound control issues. Sandy Zuschlag did some of the best sound studies on this park throughout the years by doing on-site surveys, by doing on-site monitoring. The elevation of that park going down the hill off the Edith escarpment down to other areas, based on the wind, the relative humidity, the barometric pressure, and so forth, all impact the sound. And the guy can't sit on his damned computer and model that correctly. It takes on-site monitoring, and that needs

to be done. Ms. Zuschlag did that for years. I'm very disappointed in this. And I would like to really see proof in the pudding of United Soccer and so forth trying to work with the community. I don't see it now and haven't seen it. And I'll catch my breath now, Mr. Crump.

**Philip Crump**

All right. OK, thank you, Steve.

**Steve Wentworth**

Oh, one last thing, though, I would really appreciate it if the agents for this use and the city Parks and Recreation did not lie – lie – in their staff reports about issues. And that's been done and continues to be done, so with that I'll be quiet. Thank you.

**Philip Crump**

Michael, you've been waiting for a while

**Michael Haederle**

Thanks, can you hear me now?

**Philip Crump**

Yes

**Michael Haederle**

Thank you. I just wanted to briefly address something that Jared Winchester said earlier, which is that the decibel level at the site would be 90 decibels. That is actually at a level that can induce hearing damage in people. So, how about literally starting with the concept of dialing it back to a level that wouldn't actually be dangerous to the people that are at the stadium, which would in turn at least make a step in the direction of inflicting less noise on the neighborhoods off to the west. I also just wanted to briefly mention that the sound study that was done by the Anthony James Partners was really, really thin and based on a lot of erroneous information. It actually dramatically overstates the distance from the stadium to the properties out on Edith Boulevard by, like, 25%. So, what it's basically saying, you know, "Oh, there will be x decibels at Edith Boulevard," it would actually be substantially louder, because it's actually much closer to the stadium than what they are saying – the details on their map. And I verified it with GPS data on Google Maps. I just wanted to briefly wonder, Brooke, I think, earlier in a message said that, or suggested, that we invite Mr. Trevisani to speak up, since he's, I think, dialed in on this. I don't think Ron's in a position, actually, to say much that's definitive, but maybe the principal owner of the team could give us something more substantial.

**Philip Crump**

All right. Laura Tweed, go ahead. You're muted.

**Leslie Linthicum**

Did you call on me?

**Philip Crump**



I was calling on Laura.

**Leslie Linthicum**

Oh, sorry.

**Philip Crump**

So, the microphone, bottom row, all the way to the left.

**Laura Tweed**

OK. Now. You hear me?

**Philip Crump**

Yes

**Laura Tweed**

Hello, can you hear me?

**Philip Crump**

Yes.

**Laura Tweed**

Yes. My name is Laura Tweed. I'm a local Realtor with New Mexico Land and Cattle. And I'm very concerned about all of the issues that trying to put the soccer stadium at Balloon Fiesta Park has caused. And very little support, mostly opposition. And I personally feel like the whole stadium issue is not really aboveboard. And I agree with a lot of the people that why not locate it elsewhere where you'd have more room and more support to put it there? And the one thing that everybody agrees on is that there's going to be more noise, more traffic, more light pollution, which is already pretty, pretty strong. during the Fourth of July and the Balloon Fiesta. And I can't see it going down. I just see it continues if this is allowed to happen. But the one thing that no one has really stated or mentioned, I feel like this is gonna devalue property on Edith and in that whole corridor's strip. And I do represent several people in this respect. So, I've don't think this has been taken into consideration. And when you stop and think about it, what does one have as their lifelong being, other than their homes? And so, I think it's just problematic that it's going to be decreased values when everything is said and done if the stadium's allowed to build. Thank you.

**Philip Crump**

Thank you, Laura. Leslie, please.

**Leslie Linthicum**

I think the overwhelming message or question in the comments is, is this a done deal? So I think I'd like to ask Ron and Peter, and anyone else with United? Do you believe this is a done deal?

**Peter Trevisani**

Hi, it's Peter. And I'm happy to weigh in. Like some other people, I haven't had the best internet service today. So I was trying to keep my picture off. If it gets choppy, I'll just turn it off. So, no, Leslie, I don't think this is a done deal. I think that we are trying to build an asset that is for the community, including the people that live in this neighborhood. And I've heard most of the comments tonight. I haven't been on for 100%. But I think I've gotten enough to say that, from my perspective, and Ron's and the owners, we hear people loud and clear, we understand that this is potentially a disruptive project. And we want to work with the neighborhoods to figure out a way to build this facility in a way that can enhance the area and not create a situation where people are feeling that it is materially driven, or change their area. I know that's a lot, it sounds like a press release, I understand, OK, so I am acknowledging that. But the only way we can do that is to sit down at a table and discuss the issues. I know this is part of it, it is not possible to do that all in 90 days. And I'm happy to do that at any table, I'm happy to do it in a roundtable. I'm happy to do it at your kitchen table and meet one-on-one. Let's go through what it is. But at the same time that we need to work on that, we also need to create amenities that that take, uh, that really recognize that our city is growing, and we need amenities for our young people, good healthy outlets for our young people to lean into, so that our city can grow while being respectful of its roots. And we feel very strongly about that. So we don't want to grow at any cost. We're not a real estate development company, this isn't a 'let's just make a ton of profits.' This is about – our profits are really in community dividends, not in not in dollars and cents. And all the owners are members of our community. So what I would suggest and I really like a way to have a forum to do that, is to have some of these meetings and work out, have a list of the issues. There may be some things we could do, like limit or restrict fireworks, there's maybe some things we can't do, like put a roof on the building, because it costs \$100 million, and it's just not economically feasible. But let's go have that discussion so you can understand what our lever points are, we can understand what your lever points are, and maybe you can work on a compromise so that if this is built, because it's not a done deal, but if it is built, it's done in a way that has minimal impact to the community, not maximum impact, negative impact to the community, to the immediate community. So I'll just I'll take a pause there.

### **Leslie Linthicum**

And one point to that, you know, we're, I think not everyone on this call, but a lot of people are appellants right now in a quasi-judicial process. So I don't, I don't know that one-on-one meetings between the parties is probably appropriate, until we've exhausted that process. This *is* a meeting, where we are together with a mediator, and it is it is crazy-making and maddening that it is going this way, because we keep bringing up our concerns. And you all keep saying, and I quote, 'We're open to listening to all your concerns.' Well, we're telling you them, please listen to them and please be responsive to us.

### **Peter Trevisani**

So everyone has, there are some concerns that seem to resonate with all, there's some concerns that resonate with some, but not others. Some people are more worried about fireworks, some people are more worried about their sightlines. Some people are worried about traffic, some people are worried about drinking. So we need to figure out a way to organize all the issues so that we can go through them one by one. And so we have, you know, I think Jared has presented studies on lighting and sound. There the studies that, that were done. If you don't, if you believe those studies were done an error or, or something else, then then we need to do more studies or the neighborhood needs to do

some studies. But you know, we're trying to share with you the work that we've done as honestly and openly as we can. We're not –

**Leslie Linthicum**

Could you maybe

**Peter Trevisani**

INDISTINCT – to like to work through the issues? Yeah. And what are the priorities? What are they?

**Leslie Linthicum**

Well, I mean, I think, you know, a lot of people want to know where else you looked to put this stadium and why you chose this site? And could you please change your mind?

**Peter Trevisani**

OK. I hear that. I understand there's people that don't want to see regardless of how long the lease is, what the community benefits are, if there's a roof, if there's no fireworks. And we understand that, so we're not gonna be able to accommodate everyone. That's what I'm saying. So there's others that might be OK with it or in favor of it if we did a few things. We have looked a lot of places. I think someone mentioned, yes, I have a home in Santa Fe. I also live on Central and Third downtown, which was the first place we looked. So it was putting a stadium in my particular backyard in that case, and it was turned down. It was a public stadium that got voted down. So we then looked for private options. We talked to UNM about some land over by UNM. I believe there is maybe a Target going in on the land on South Broadway They want to put different restaurants and fast-food chains in there. They have a different plan for that. There's also a lack of infrastructure there around parking, so that we've been told no. We spent a lot, we worked with them in a very respectful way, but it just wasn't a good fit. So that that was out. Mesa Del Sol, is also not an option for a number of reasons. One is that the traffic to get in there is impossible with one facility. It doesn't have the ingress and egress the Balloon Fiesta Park has, where as you know, it can handle, not well, 80 to 100,000, people. We're 5, 6, 8 – 10,000 at the most, so we should be able to handle the ingress and egress to the north side away from the neighborhoods. It's very important to me personally, and to the project. So we're using barricades to protect those roads to the west, the roads coming in from the south. We'll just block them off. And if people want to park in the streets, and the city needs to get a tow truck and tow them if they're parked illegally. I mean, that that will change their behavior. So I think we have to rely on some of those uses. So, we've looked at other spaces, the answer is always the same. It's either, "No, it's not going to work, the land isn't available." We're in our fifth year, we're not in our fifth month. And the one thing about Balloon Fiesta Park is it has a lot of infrastructure there already. We don't have to plow 30 acres of natural land for parking if there's already parking lots there. There's already – it's a 400-acre park. So we could sit up on the far east side, and we believe we could build this facility in a way that that can serve everybody. That's our belief. And so that's why we're here. We're not here just because it was, you know, we just decided, you know, because we didn't look at other options.

**Leslie Linthicum**

Because it was your last resort. And you were turned down everywhere else.

**Peter Trevisani**

No that's actually, what's ironic is the city brought this up very, very early, as a possibility. And we really wanted to focus on downtown. We wanted to focus on downtown so it could be a catalyst, an economic catalyst, to help bring people downtown, to help reduce crime and drug use downtown, to bring dollars into that area to help with homelessness. We really felt that having a stadium in the Railyard area could be a catalyst for an area that's been in a steady state of decay for many, many years and only took a big step back during COVID. So we were laser-focused on that site for many, many years. And by the way, when we talk about business plans, that was the least economical, by far, for the team. No parking revenues, not as much concessions, a lot of risk. If there was if there was an event down there, such as a shooting or some kind of mugging, it could scare people away. We were willing to do it because we felt it had the biggest impact for New Mexico and for the community. So that was where we were focused, and then after COVID, we needed to pivot because that was not an option.

**Leslie Linthicum**

Turning to your roof, did you say – does the stadium cost \$30 million, about?

**Peter Trevisani**

So there's a couple of things when you're talking about the stadium costs, and I think you're referencing the number out of the lease. First of all, the lease calls for the team to invest a minimum of \$30 million of private money into the vertical of the stadium. So if you're building a stadium from scratch, you have to do that. But you'd also have to create a parking lot, you'd have to create all the infrastructure, the power lines, the water, the sewer, all the things that – the roads that go in and out if you're way out in a rural area, on a dirt road. And so, you know, if those were all added up, it's quite a bit more than \$30 million. And the team will likely put in more than \$30 million, because that's what will be needed to do some of these things that we've talked about here to try to, you know, restrain noise, spend more money on more expensive lights so that we don't have lights being cast in in wide shadow. So these are the things that we're actively working on to reduce or eliminate.

**Leslie Linthicum**

I asked about the cost because the additional cost of a roof seems crazy. One hundred million dollars more to put a roof on it.?

**Peter Trevisani**

Potentially. Arenas are notoriously more expensive than, you know, stadiums or field houses. Again, this is a stadium for 8 to 10,000 people this isn't a big football stadium with 80,000 people. It's not near, it's not even as big as Isotopes Park. So we will, we are talking about and contemplating some, some partial roofing structures that will deflect the noise down and I think it's been pointed out there are some natural embankments that should help contain the noise. But I, but I think there's been a lot of points brought up that let's go deeper on that study and really figure out, you know, what the noise is and how many homes are impacted, and. I'm not sure what the closest house is to the center of that facility, but I'm gonna guess it's at least a third of a mile. But I need to go out there and, you know, my understanding or if someone what is I know it's 100 feet from the park but we're all the way on the east side of the park through all those fields.

**Michael Haederle**

They're 2,000 feet.

**Leslie Linthicum**

Two thousand feet to from where I'm sitting right now speaking to you.

**Peter Trevisani**

And how many feet in a mile? Is it 6,500? I'm sorry, my, it's been a long time since fifth grade.

**Michael Haederle**

5-280.

**Peter Trevisani**

5-280, so, a little, about a third of a mile.

**Leslie Linthicum**

It's close.

**Peter Trevisani**

So I'm generalizing a little bit. About a third of a mile. That's, that's not 100 feet, that's not a mile. It's a third of a mile. And that's where you're sitting, Leslie, so let's work on your home, if you're the closest resident. What can we do to keep the decibel levels down, the light down? I know you don't want it at all. So, but if it does happen, let's do it in a way that you feel like you were, you know, we did what we could to reduce your concerns.

**Philip Crump**

So Peter, you had talked about addressing the issues. And I would hope that – and here's where everyone on this call can help. When I send out the report, I would hope it has a complete and accurate depiction of the issues that had been raised. And the specific concerns, and can be used as a tool for the planning team, for all of you to consider modifications to the plan. As you say, the things that you can do, as well as the things that you can't do. So, that's the hope. And let me say again, if you have not already received an email from me, and you want to receive the report, please put your name, your affiliation and your email address in the chat, so that I can send you the report. And, Pat, you've been waiting, I can comment.

**Pat Hauser**

Let me click the red button so I get it properly done here. So, I appreciate the time. I just like to open it up, because first of all, all it takes is for bad things to happen is for good people not to say anything. And so I think you've heard a lot of people that are really concerned about this and are vehemently opposed to it. I'm personally opposed to it. And as the vice president of the neighborhood association, and the community property owners, as a group are opposed to this stadium in our backyards. And you know, I know you live in Santa Fe, and you said you have property downtown. That's all wonderful and good. But I still say that you would not want something like this around your 5,000-square-foot home that you have invested, you know, millions of dollars in. We've invested hundreds of thousands of

dollars in our homes and our properties here. This is purely for political, personal and financial gain that factually impacts this underserved and unrecognized neighborhoods that have lived with amplified sound, concert fireworks and various events that are not controlled or monitored by Parks and Recreation Department in the past. So if proven facts are, what's going to change? Nothing, because they can have this going on – they, being Parks and Recreation – and in the future. Sounds like your organization is that it's left us to taxpaying citizens to police these activities that have no enforcement capabilities for decades. The facts don't lie. The facts don't lie. And the fact is, is that this is the wrong thing in the wrong spot at the wrong time. For all the reasons, and if it costs \$100 million to put a roof on it, then spend \$100 million. You got a 60-year lease going on this thing. So, amortize that out over 60 years, you're gonna get performance bonds, the city has said they'll back to your bond issue so run the bond issues, get the money, the money's out there. Garcia's got it, you got it. The other people that are investors got it. You know you're hiding behind the facts, is that you can put a roof on it so to protect us. Because you don't care. You live in Santa Fe, and Ron Patel lives out at Mesa del Sol. And Mr. Garcia doesn't live out here. We do. We live with this. I've lived here for 57 years. I know what this is going to do to us, because I live with what the Parks and Recreation does now. They don't care. And by you and Patel, gaslighting all of this, it's very, very obvious that it makes no difference that the train is on the track, and you're going to run over each and every one of us, come hell or high water. Thanks for your time.

**Philip Crump**

Thank you, Pat. Peter.

**Peter Trevisani**

Yeah, Pat, I just say, I would respectfully disagree that I don't care about, about you, or the community. And I think you're taking a lot of liberties with what you're saying there. I think we have a track record of being stewards to the community. New Mexico United as an entity is a community-driven entity. The money that you're talking about, that you think we're making, is – doesn't exist. The money goes back into the community, and will continue to go back into the community. And so I understand that this is an upsetting project for you. And we want to work through that. But I think to say that we don't care. It's really, it's a little, you know, I'd like you to think about what you're saying. And we do care deeply and have shown that over a long period of time.

**Philip Crump**

All right. Thank you, Peter. Brooke, go ahead.

**Brooke Jordy**

Thank you, Mr. Crump. Mr. Trevisani, has the United business plan for the stadium been shared with the city or anyone involved with the city?

**Peter Trevisani**

I think, Brooke, when you're talking about the business plan. I don't, I don't think there's a document that exists, at least how I'm interpreting what you're talking about. We worked with the city. Remember, we're a tenant with the city, we're leasing the land from the city, we have to make lease payments to the city. And it's our responsibility to pay for the stadium and service the stadium and operate the



stadium and maintain the stadium. And so, all those responsibilities are on New Mexico United. They're not a burden of the city.

**Brooke Jordy**

Well, I just mean, because Mr. Patel referenced the business plan a few times. And I'm wondering if that business plan is memorialized in a document.

**Peter Trevisani**

I'd have to talk to Ron about the business plan that he's referencing. But there's not – if you're asking if there's a business plan that talks about New Mexico United in our private business, there's no, there's no business plan on public records.

**Brooke Jordy**

I meant, like the use of the stadium, how the stadium will be used, how you guys will kind of, you know, bring financial benefit to the area, to New Mexico, and then to recoup some of the cost.

**Peter Trevisani**

I mean, the primary use of the facility would be to host the men's soccer games, which has been talked about. We also have been very open that we would like to and aspire to bring a professional women's or at least an amateur women's team to the state. We believe that the, that that would that that could attract between 4 to 6,000 people per game. We don't, and we think it would do a lot more than just attract people. It would be a great, it would create a lot of role models for young girls and young women in New Mexico. If you're talking about other events, such as concerts, that is not a material part of the business plan. I think that's probably what everybody is worried about. Are we going to have 50 concerts? No, we're not going to have 50 concerts. Could we have concerts? As long as we sit, fall within the ordinance, yes, but that's not what we're doing. We're not Live Nation. We're not Isleta, we're not Sandia. We're not – that's not our core business, so –

**Brooke Jordy**

And the ordinance being the city sound ordinance?

**Peter Trevisani**

There is a city sound ordinance, yes.

**Brooke Jordy**

Is that what you meant when you said the ordinance?

**Peter Trevisani**

That is one of the ordinances. I assume there are other ordinances about sound and about curfews and, and such.

**Brooke Jordy**

And how have you guys worked with the county to ensure that you're complying with county requirements, since a majority of the neighbors who are here today live in the county?

**Peter Trevisani**

So I would say in terms of direct discussions with the county officials? I haven't been part of those direct discussions. But I think certainly hearing what those ordinances are, and to the extent they differ from the city's ordinances, then we would absolutely want to consider those, even though we're not obligated to do so.

**Brooke Jordy**

OK. And a few times tonight, we have heard discussion of some community engagement plan or community benefit plan, and I'm, I'm wondering, when are we going to see some kind of written documentation of that community benefit plan?

**Peter Trevisani**

Well, I, that's a good question. And I think that's something we should work towards. I don't think there's been a date set. I think it was pointed out, I can't remember exactly who spoke, it was very early in the meeting, about that. Those plans, that that language comes from the city. But at the end of the day, we want we would, my preference would be if we're just being blunt, I'd rather work on an agreement with the neighborhood so that we can move forward with the facility and get to the point that we could do that, versus dragging everyone along and kicking and fighting. And, and I think to do that, let's – we've heard a lot of issues tonight, and let's have those meetings. Maybe we can put together a plan sooner rather than later that can limit certain things or put more parameters that people want. We're more than open to it.

**Brooke Jordy**

Your deadline with the USL is end of the month?

**Peter Trevisani**

Our deadline with the USL is not end of the month. The USL has a stipulation that we need to be playing in a soccer-specific stadium or showing a very clear pathway to that with the lease with the city. We have shown that we have a pathway, and we have time, but we don't have an infinite amount of time to – we cannot play in a baseball stadium, for a number of reasons. One of which, you know there's a good chance Major League Baseball won't allow us to play the baseball stadium in a few years. So if we don't find a place to play, then we're not going to have these teams. And we think that these teams are a valuable part of our community – one of many assets, not the asset, just one of many assets, but a valuable one.

**Brooke Jordy**

Oh, I thought that Isotopes is minor league.

**Peter Trevisani**

it is minor league, but they are under the umbrella of Major League Baseball.

**Brooke Jordy**

So when is the deadline for you guys, again?

**Peter Trevisani**

Our deadline has passed. We've asked for an extension it is – and with the city lease, we have been granted one.

**Brooke Jordy**

And when is that?

**Peter Trevisani**

It's, I mean, I'm not understanding. I'm sorry, when is the extension?

**Brooke Jordy**

How long is the extension? Yeah, correct.

**Peter Trevisani**

Well, I think as long as we're tracking to a path to completion, they would work with us. But if it was if it was to come to an end, then I think that would be a very difficult situation for the team.

**Brooke Jordy**

OK

**Philip Crump**

OK, it is a little after 7:30. We've had lots of discussion. I want to thank everyone for speaking up. I'll do my best to get the report out within 48 hours, or less. Please look it over. If there are errors of omission, something important that was left out, let me know. If I've made a mistake in reporting something incorrectly, let me know. I will issue amendment so that the report is accurate. I want to thank not only all of the neighbors who have spoken up, everyone who has provided their email addresses so I can send out the report, the planning team, Jackie and Jared, in particular. And Peter and Ron from New Mexico United. Understand there's tremendous opposition among the nearby neighbors that will be reflected in the report. And the next step is an EPC hearing. Jackie, when is that hearing scheduled?

**Jackie Fishman**

The hearing is scheduled for March 21.

**Philip Crump**

OK, and will that be accessible online?

**Jackie Fishman**

Yes, EPC hearings I believe, are by Zoom.

**Philip Crump**

Right, and I think I do have that address. That will be in the in the report, toward the end, the Zoom address for that meeting.

**Jackie Fishman**

Philip, I can send you the link, just to be sure, but they start early in the morning. I'm told it's a big agenda, so it's likely to be a long day.

**Philip Crump**

Right. I will also include in the report a link to the EPC listing of the agenda. Their March agenda has not yet been posted. It should be, shortly.

**Jackie Fishman**

The agenda gets posted a week before the hearing. It will be available to everybody on March 14, as will the updated staff report.

**Philip Crump**

OK, so the agenda will be available on the 14th. And is the staff report accessible through the EPC?

**Jackie Fishman**

The staff report, the agenda link is INDISTINCT for the city Planning Department. INDISTINCT for EPC.

**Philip Crump**

OK. So we'll provide as much information for neighbors as possible. Peter and Jared have both have raised their hand. Go ahead, Peter. And then we'll hear from here the final words of wisdom from Jared. Go ahead, Peter.

**Peter Trevisani**

So my hand was just up from a previous, so I put it down.

**Philip Crump**

OK. Thank you, Jared

**Jared Winchester**

There was a few comments, talking about the condition of the stadium contextually relative to the neighborhoods that I wanted to just clarify some of the numbers on, because I think that matters. Because whether you say a half or a third of a mile is about perception. A third of the mile is 1,700, around 1,765 feet. The distance that we use, in the sound study, that Michael, I know, you push back on some of the numbers, and I understand how you measure them accounts for some discrepancy, it's not to the level of 25% of the discrepancy. We're measuring, even though maybe the graphics imply from an edge to an edge of neighborhood, to edge of the stadium, we're measuring from the center of the sound source, which is the center of the stadium. And we're drawing a line to the nearest edge of the residence and not the property line. So one, I just wanted to clarify where those numbers come from, so when you do that, and you draw a line from the center of where the stadium is, not the far west edge, and you draw that to the nearest houses, you get a number that's right around 2,500. So it's about 47 to 48% of a mile, just a hair under half. So that is, in terms of characterizing the distance broadly, which was used earlier, where that number came from. And I just wanted to clarify that. And the other thing, just contextually, is in different times, it has been stated that we're locating this on the

balloon field. We are not locating this on the balloon launch field, which implies a more natural state out on the grass. We're locating this on the far edge, an asphaltic millings parking lot near the edge of an eroding escarpment with a lot of windborne and, and rain-driven dust and sedimentation within the edge of a failing landfill boundary, and seeking to remedy all of those site conditions as a part of the stadium. And it's important to note that because of the value the stadium is intended to provide, versus the perception of it as being an intrusive and degenerative impact on its site.

**Philip Crump**

OK. All right. Well, thank you all for participating. And look for the report in the next day or so. And I wish you well. Thank you very much.

**From:** [Pat Hauser](#)  
**To:** [Planning EPC](#)  
**Cc:** [Bolivar, Silvia A.](#)  
**Subject:** FW: March 21, 2024 written comments for hearing AC-23-22  
**Date:** Sunday, March 10, 2024 11:02:20 PM  
**Attachments:** [Written cooments 3.10.2024 with attachemnts.pdf](#)  
[Fishman notificaiton letter.pdf](#)  
[Soccer Horn Noise.pdf](#)

---

[EXTERNAL] Forward to [phishing@cabq.gov](mailto:phishing@cabq.gov) and delete if an email causes any concern.

This was rejected on the below e mail. Please ensure this is included in the record as I have changed the domain address.

---

**From:** Pat Hauser <hdhauser@comcast.net>  
**Sent:** Sunday, March 10, 2024 10:58 PM  
**To:** 'sabolivar@cabq.gov' <sabolivar@cabq.gov>  
**Cc:** 'PlanningEPC@cabq.gov' <PlanningEPC@cabq.gov>; Brooke Jordy <brookemjordy@gmail.com>; Maggie Rose <gypsy.rose46@gmail.com>; t-marie-v@hotmail.com; Michael Haederle <haederle@yahoo.com>; Steve Taylor <staylor@taylortowers.com>; Steve Wentworth <Anvanews@aol.com>; Peggy Norton <peggynorton@yahoo.com>  
**Subject:** March 21, 2024 written comments for hearing AC-23-22

Good evening,

Please find attached my letter for the EPC hearing, to be included in the record.

Please acknowledge receipt of attached documents.

Regards: Pat Hauser Cell: 505-228-7106  
[hdhauser@comcast.net](mailto:hdhauser@comcast.net)



March 10, 2024

Environmental Planning Commission  
City of Albuquerque  
C/O Silvia Bolivar  
[sabolivar@cabq.gov](mailto:sabolivar@cabq.gov)  
[PlanningEPC@cabq.gov](mailto:PlanningEPC@cabq.gov)

**Via Electronic Mail**  
**Appeal No. AC-23-22**

**Written comments for March 21, 2024 Hearing-Balloon Fiesta Park Stadium**

Ms. Bolivar:

My wife Sylvia and I have lived in the Maria/Diers neighborhood for 57 years. We both register our full opposition to the proposed multi-use soccer stadium being planned for Balloon Fiesta Park. This proposed stadium is being placed in-between two prominent neighborhoods and will adversely affects the adjacent multiple property owners; as well as tax paying citizenry. Our tax dollars will be used to support this stadium and the extensive infrastructure required to support a construction project.

This stadium proposal from the onset at a presser by Mayor Keller and his multiple staff members on March 30, 2023 has been indigent to the appropriate People, Process, and Procedures for open government and communication.  
“See attached recent e mail letter to Ms. Jackie Fishman”.

There are multiple concerns we feel are of significant importance as we ask for a unanimous vote to reject this master plan amendments as written.

The Balloon Fiesta Park master plan of 1998 and the updated 2012 master plan never included an outdoor sports stadium and stated that “One would not be allowed-Page 17, 2012”.

The city ordinance regarding the Balloon Fiesta Park Commission, has since the published agenda of August 29, 2023, has been ignored in this rushed process being orchestrated and pushed by this administration.

The issue of the outdoor sports stadium was scrutinized by considering the immediate irreversible impact on the surrounding predominantly A-1 zoning and the unique character of this area of multiple neighborhoods. The comprehensive plan of Albuquerque and Bernalillo County notes that there are multiple communities that are worthy of protecting. This does none of that. The comprehensive plan as well as the integrated development ordnance plan was meant to “Protect all Communities from many of the identified following issues”.

- Concerns regarding uncontrolled noise “Soccer Horn Noise: Impact on Games attached” Research has shown crowd noise levels in a soccer stadium was 136.6 decibels. Research has also shown the VUVUZELA type horn “attached” are easily obtained and used.
- Lighting pollution that will impact our quality of life as it impacts adjacent residential property owners in the predominately residential area.
- Uncontrolled traffic problems in and around the park that we endure and live with during Ballon Fiesta. With the undisclosed number of uses this will continue to be problematic for we the property owners HUNDREDS OF TIMES A YEAR as is being proposed.
- Non specific uses at the stadium such as CONCERTS and other large events which uses would have a negative and everlasting “60 YEARS” on the adjacent property owners and other park activities.
- The sound studies are problematic due to the fact they are and have been “computer generated” vs on site amplified sound in the stadium area at the proposed 70 foot or higher stadium levels that is notable higher than the surrounding residents. The lighting studies are also problematic in the fact that the stadium location is elevated over the predominantly West property owners. The Improved Group utilized the Weidner Field in Colorado Springs wherein the stadium sits in a downtown depression and where the former Zimmerman Steel Company existed for their arial depiction of light. This stadium will set elevated over the West residents of North Edith and Maria Diers neighborhoods.

What is the Solution? Ideally build the stadium at Mesa del Sol. The Isleta Amphitheater is in the area and hosts thousands of spectators and the access is well documented. The area which is adjacent to the current stadiums located between Cezar Chavez and Gibson bound on the East by Yale and the West by I 25 is another solution which would not damage the citizenry. Or West 98<sup>th</sup> street just off of I 40. Rio Rancho Paso del Volcan or the Pueblo of Sandia since they are a primary sponsor. Another option would be to cover the stadium with a roof that would contain the crowd noise and limit the activities associated with tailgate parties, fireworks, and restrict the use of alcohol.

The Balloon Fiesta Park is not a desirable location for this multi-use stadium EXCEPT for the profit to be recognized by the investors and the political influence of this administration.

**In closing: All it takes for bad things to happen is for good people to do nothing.**

My interpretation of the Environmental Planning Commissions duty as well as responsibility is to protect, we the residents and property owners form the afore mentioned facts that will forever change the rural character of the North Valley.

**None of these people live here.**

**This will be in our backyards.**

Consensus planning, City of Albuquerque and United New Mexico have been arbitrary and capricious in their desire to change the current Balloon Fiesta Master Plan thus allowing an open outdoor sports stadium. **Professional Commercial use tenants of the park were never encouraged or sought after until this administrations quest for this forever altering multi-use stadium**

Regards:

Handwritten signatures in blue ink. The signature on the left is 'Pat Hauser' and the signature on the right is 'Sylvia Hauser'.

Mr. Pat Hauser  
Vice President, Maria Diers Neighborhood Association  
Mrs. Sylvia Hauser  
134 Maria Circle N.W.  
505-228-7106

Attachments:

## Pat Hauser

---

**From:** Pat Hauser <hdhauser@comcast.net>  
**Sent:** Wednesday, February 28, 2024 10:54 PM  
**To:** 'Pat Hauser'  
**Subject:** RE: Meeting Notification - Balloon Fiesta Park / NM United Stadium

---

**From:** Pat Hauser <hdhauser@comcast.net>  
**Sent:** Wednesday, February 28, 2024 9:42 PM  
**To:** 'Jackie Fishman' <fishman@consensusplanning.com>; mgriffie@noreste.org; sec.dist4@gmail.com; edueweke@juno.com; kbbh@hotmail.com; ggarcia103@comcast.net; 'Maggie Rose' <gypsy.rose46@gmail.com>; anvanews@aol.com; 'Michael Haederle' <haederle@yahoo.com>; Pat Hauser <hdhauser@comcast.net>  
**Cc:** 'Charlene Johnson' <Johnson@consensusplanning.com>; brookemjordy@gmail.com; staylor@taylortowers.com; alamedamontoya@gmail.com; christinebnvdz@aol.com; 'Tina Villegas' <t-marie-v@hotmail.com>; emyers\_11@yahoo.com; stemax1@aol.com; grumpyeh46@comcast.net; 'BARI Harvey' <boyznbari@msn.com>; 'Sandy Z' <szuschlag58@gmail.com>; 'Bolivar, Silvia A.' <sabolivar@cabq.gov>; wbenson@bernco.gov; Peggy Norton <peggynorton@yahoo.com>; Steve Wentworth <Anvanews@aol.com>  
**Subject:** RE: Meeting Notification - Balloon Fiesta Park / NM United Stadium

Good morning Ms. Fishman: For the record this would seem as if there is another RUSH and PUSH to get this meeting completed due to the short notice and timeframes just to get a box checked.

It would seem problematic to me and others that this process may leave many concerned and interested people and property owners inappropriate time to plan for such a meeting.

I believe that giving less than 3 business days' notice regarding a public facilitated meeting about the City of Albuquerque Land Use APPEAL NO.AC-23-22 is problematic and may not comply with appropriate notice for such a complex and long-lasting impact on the future of multiple property owners.

This should be held in an appropriate location such as the City Council chambers or the County Chambers as a neutral location. There is possible issue with some individuals not having access to the internet or personal commitments that may have been arranged prior to this short-rushed agenda meeting process.

In the past notification for an EPC meeting allows interested parties appropriate and ample time for planning and preparation. This does none of that.

It is also problematic that comments have been limited in time of 2 minutes. This issue being so complex needs a much better communication process regarding the Neighborhood Associations and the affected property owners.

Based on previous meetings and communication input from non-proximity parties is inconsequential as it relates to the direct and forever impact on, we nearby residents. It is basically in our backyards.

My suggestion and recommendation are to have the meeting scheduled on a weekend such as March 9, 2023 allowing proper planning for all affected parties.

Thus, allowing for PEOPLE, PROCESS, AND PROCEDURES to be sensitive to the issues and challenges at hand.

It would also seem appropriate to have the entire City of Albuquerque Balloon Fiesta Park Master Development Plan rewritten vs the current select editing for one specific request as outlined in your communication.

Awaiting a positive response regarding the critical need to reschedule this communication process.

Regards: Pat Hauser

---

**From:** Jackie Fishman <[fishman@consensusplanning.com](mailto:fishman@consensusplanning.com)>  
**Sent:** Wednesday, February 28, 2024 7:22 PM  
**To:** [mgriffie@noeste.org](mailto:mgriffie@noeste.org); [sec.dist4@gmail.com](mailto:sec.dist4@gmail.com); [edueweke@juno.com](mailto:edueweke@juno.com); [kbbh@hotmail.com](mailto:kbbh@hotmail.com); [ggarcia103@comcast.net](mailto:ggarcia103@comcast.net); Maggie Rose <[gypsy.rose46@gmail.com](mailto:gypsy.rose46@gmail.com)>; [hdhauser@comcast.net](mailto:hdhauser@comcast.net); [anvanews@aol.com](mailto:anvanews@aol.com); Michael Haederle <[haederle@yahoo.com](mailto:haederle@yahoo.com)>  
**Cc:** Charlene Johnson <[Johnson@consensusplanning.com](mailto:Johnson@consensusplanning.com)>; 'brookemjordy@gmail.com' <[brookemjordy@gmail.com](mailto:brookemjordy@gmail.com)>; 'staylor@taylortowers.com' <[staylor@taylortowers.com](mailto:staylor@taylortowers.com)>; [alamedamontoya@gmail.com](mailto:alamedamontoya@gmail.com); [christinebnvdz@aol.com](mailto:christinebnvdz@aol.com); Tina Villegas <[t-marie-v@hotmail.com](mailto:t-marie-v@hotmail.com)>; [emyers\\_11@yahoo.com](mailto:emyers_11@yahoo.com); 'stemax1@aol.com' <[stemax1@aol.com](mailto:stemax1@aol.com)>; [grumpyeh46@comcast.net](mailto:grumpyeh46@comcast.net); BARI Harvey <[boyznbari@msn.com](mailto:boyznbari@msn.com)>; Sandy Z (<[szus Schlag58@gmail.com](mailto:szus Schlag58@gmail.com)>); [szus Schlag58@gmail.com](mailto:szus Schlag58@gmail.com); Bolivar, Silvia A. <[sabolivar@cabq.gov](mailto:sabolivar@cabq.gov)>  
**Subject:** Meeting Notification - Balloon Fiesta Park / NM United Stadium

Dear Neighbors:

The purpose of this email is to provide notification that the Balloon Fiesta Park Development Plan/Site Plan for Subdivision and Site Plan-EPC for a United New Mexico Soccer Stadium was remanded to the Environmental Planning Commission (EPC) by the Land Use Hearing Officer (LUHO) following an appeal by adjacent neighborhood associations. As part of the remand, the City of Albuquerque is inviting neighborhood associations and neighbors to a facilitated meeting to discuss the request.

The facilitated meeting will be held on **Monday, March 4, 2024, from 5:30 to 7:30 pm**. Representatives from the City of Albuquerque and New Mexico United will be in attendance to answer any questions and listen to community input. The meeting will be facilitated by a City contractor and held online via Google Meet using the link below.

[meet.google.com/xec-uycp-xea](https://meet.google.com/xec-uycp-xea)  
Join by phone +1 414-909-3864, PIN 106965974

The EPC hearing will be held on **Thursday March 21, 2024, starting at 8:40 am**. The public is invited to attend the hearing and provide input regarding this project, which will be held via Zoom using the link below:

<https://cabq.zoom.us/j/2269592859> or by calling the following number: 1 301 715 8592 and entering Meeting ID: 226 959 2859

If you have any questions or concerns, please do not hesitate to contact myself at [fishman@consensusplanning.com](mailto:fishman@consensusplanning.com) or you may also contact the City of Albuquerque Planning Department at [devhelp@cabq.gov](mailto:devhelp@cabq.gov).

Sincerely,

Jacqueline Fishman, AICP  
Principal  
Consensus Planning, Inc.  
302 Eighth Street NW  
Albuquerque, NM 87102  
P: 505.764.9801





30-Day Hassle-Free Returns

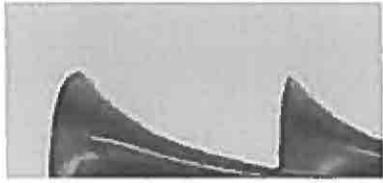

DeWalt Train Horns



< 1 2 3 >



Milwaukee Train Horn →



DeWalt Train Horn →



Ryobi Train Horn →



Portable Train Horns →

< 1/2 >

## Soccer Horn Noise: Impact on Games

Chat





🔗 Share

Did you know that the sound emitted by a popular instrument in soccer stadiums around the world can reach nearly 120 decibels? That's equivalent to a rock concert or a chainsaw! This instrument, commonly known for its controversial and polarizing nature, has its roots traced back to South Africa in the late 20th century. The instrument gained prominence during the 2010 FIFA World Cup, captivating countless fans with its unique and instantly recognizable sound. Despite generating criticism from some quarters due to its potential to disrupt play or annoy spectators, this instrument has become an essential part of the soccer experience for many fans.

Known for its vibrant and enthusiastic supporters, soccer has an unrivaled ability to unite people from different cultures and backgrounds. In recent years, the use of this instrument in soccer matches has transcended borders and become a global phenomenon. The instrument's origins can be traced back to the

traditional vuvuzela, a South African horn used in celebrations and ceremonies. Its piercing and distinct sound became iconic during the 2010 World Cup, leaving a lasting imprint on soccer culture.

While some see this instrument as an unwelcome disturbance, others argue that it adds to the electric atmosphere of the game. Its repetitive buzzing sound has the power to create an intense and exhilarating ambiance that resonates with fans worldwide. However, concerns have been raised about the potential negative effects this instrument might have on player concentration and overall spectator experience. Despite these concerns, the instrument's popularity continues to grow.

From its humble beginnings in South Africa, the instrument has now become a staple in soccer stadiums around the globe. Fans have embraced it as a symbol of their passion and loyalty, using it as a way to express their support for their favorite teams. In fact, it is estimated that over 1.5 million instruments were sold during the 2010 World Cup. Love it or hate it, it is clear that this instrument has left a significant mark on the world of soccer.

As the instrument continues to divide opinions among fans, authorities have implemented measures to control its use in stadiums. Stadiums now have regulations regarding noise levels and usage restrictions to strike a balance between maintaining the authentic game atmosphere and ensuring the comfort of fans. It is an ongoing debate, with arguments from both sides about the instrument's impact on the game.

Ultimately, this controversial instrument remains an integral part of the soccer experience. Whether celebrated for its ability to amplify the passion and excitement of the game or criticized for its potential to disrupt play, the instrument continues to leave an indelible impression on soccer culture around the world.

#### Introduction:

Soccer horn noise, also known as vuvuzela, has become a controversial aspect of the beautiful game. It has gained immense popularity but is often criticized for its disruptive nature. In this article, we will explore the different perspectives surrounding this unique auditory experience. Is it merely a distraction or does it serve a purpose in demonstrating fan support? Let's delve deeper into the definitions and advantages associated with this distinctive sound.

#### Definitions:

The soccer horn noise, commonly referred to as the vuvuzela, is an instrument originating from South Africa. It is a long plastic trumpet-like device that produces a loud and distinctive monotone sound. Introduced to the world during the 2010 FIFA World Cup, its unique noise quickly caught the attention of football enthusiasts globally.

#### Advantages:

Despite the controversies surrounding its use, the soccer horn noise serves various advantages. Firstly, it amplifies the atmosphere within the stadium, creating an intense and energetic ambiance. It enables fans to actively participate and express their passion, elevating their sense of involvement in the game. Moreover, the consistent sound of the vuvuzelas acts as a constant reminder of the ongoing match, maintaining a consistent level of excitement throughout. Additionally, for team players, the sound can be perceived as a motivational tool, boosting morale and performance.

#### Conclusion:

While soccer horn noise has its fair share of detractors, it undeniably holds cultural significance and contributes to the unique experience of watching live football. In the subsequent sections, we will further explore the impact and controversies surrounding vuvuzelas. Join us as we evaluate the perspectives of fans, players, and authorities in order to better understand the role this distinctive noise plays in the world of soccer.

## Types of Noise in Soccer Stadiums

### 1. Crowd Chants and Cheers:

In soccer stadiums, one of the most common sources of noise is the crowd itself. Fans gather from all walks of life to support their favorite teams, creating an electric atmosphere with their chants and cheers. These energetic vocalizations can be heard throughout the game, adding to the excitement on the field.

### 2. Drum Beats and Musical Instruments:

Another form of noise commonly heard during soccer matches is the rhythmic beating of drums and the sound of various musical instruments. Supporters often bring drums, trumpets, and other instruments to the stadium to create a unique and captivating soundtrack. These sounds not only unite the fans but also serve as a means of encouraging their team and intimidating the opposition.

### 3. Whistles and Referee Signals:

Referees play an essential role in soccer matches, and their decisions are often met with loud whistles and signals. These noise-making devices not only help in relaying important information to the players on the field but also contribute to the overall ambiance of the stadium.

## The Use of Vuvuzelas

One notable addition to the soccer soundscape in recent years has been the vuvuzela. Originating from South Africa, vuvuzelas are long plastic horns that produce a distinctive buzzing sound. These instruments gained global attention during the 2010 FIFA World Cup, where they were blown incessantly by enthusiastic fans in the stands. While some find the sound of vuvuzelas an exciting part of the soccer experience, others have criticized their use due to the potential for excessive noise levels and the difficulty of communication during matches.

## Impacts and Controversies

The noise generated in soccer stadiums can have both positive and negative impacts on the game and its participants.

On one hand, the loud and passionate support from the fans can create a vibrant atmosphere that motivates players and adds intensity to the match. The noise can be a powerful psychological tool, giving the home team an advantage and potentially intimidating their opponents. Additionally, the collective noise can generate a sense of unity among fans, fostering a strong sense of community and pride.

However, excessive noise levels may have some drawbacks. The intense decibel levels can make it challenging for players and coaches to communicate effectively and may even impede on-field instructions. Furthermore, it has been suggested that sustained exposure to high noise levels during matches could have long-term effects on the hearing health of both players and fans.

## Statistics: Noise Levels in Soccer Stadiums

- The loudest crowd roar ever recorded in a soccer stadium was 137.6 decibels, during a match between Galatasaray and Fenerbahçe in Istanbul, Turkey in 2011.
- Research has shown that noise levels in soccer stadiums can reach up to 120 decibels, comparable to a rock concert or a jet engine.
- A study conducted during the 2010 FIFA World Cup found that vuvuzelas produced sound levels greater than 100 decibels, posing potential risks to hearing health.
- In some cases, soccer stadiums have implemented noise reduction measures, such as installing sound-absorbing materials or limiting the use of certain noisy instruments.

<https://youtube.com/watch?v=efFj6uP9mls>

## Frequently Asked Questions about the Distinct Sound Heard at Soccer Matches

### 1. What is the source of the distinct noise heard during soccer matches?

The captivating hum enveloping soccer matches is generated by an instrument known as the vuvuzela. This unique musical horn, popularized by its association with international soccer tournaments, emits a characteristic sound that resonates throughout stadiums. The vuvuzela, typically made of a thin plastic tube, is played by blowing into its narrow opening, resulting in a loud and intense noise that echoes in the atmosphere.

Key pieces of information:

- The vuvuzela is the primary source of the distinctive sound heard during soccer matches.
- It is a musical horn made from a thin plastic tube.
- Blowing air into the narrow opening creates a resonating sound that fills stadiums.

### 2. How did the tradition of using vuvuzelas originate?

Originating from South Africa, the tradition of using vuvuzelas during soccer matches emerged as part of the vibrant cultural heritage of the country. These horns have long been sounded at various celebrations and events to create a festive atmosphere. While their presence at soccer matches grew significantly during the 2010 FIFA World Cup held in South Africa, vuvuzelas have been an integral part of local fandom for years, helping to create an unmistakable symphony of support.

Key pieces of information:

- The tradition of using vuvuzelas during soccer matches originated in South Africa.
- Vuvuzelas have historically been used in various cultural celebrations in the country.
- Their widespread use at soccer matches gained prominence during the 2010 FIFA World Cup.

### 3. How do vuvuzelas enhance the atmosphere at soccer matches?

By their power to create an electrifying ambiance, vuvuzelas add an extra dimension of excitement to soccer matches. The constant buzzing and humming of these horns create a continuous wall of sound, amplifying the energy of the crowd. The clamor of vuvuzelas helps unite supporters, encouraging chants and cheers while providing a distinctive soundtrack to the game. This intense auditory experience, unique to soccer matches, contributes to the enthralling spirit felt within stadiums during these high-stakes contests.

Key pieces of information:

- a) Vuvuzelas enhance the atmosphere by generating a continuous wall of sound.
- b) The noise created by vuvuzelas amplifies the energy of the crowd.
- c) The use of vuvuzelas unifies supporters and contributes to the overall excitement of the match.

4. Are there any controversies surrounding the use of vuvuzelas?

While vuvuzelas undoubtedly contribute to the vibrant atmosphere of soccer matches, their excessive noise has generated some controversy. Critics argue that the loud and continuous buzzing can drown out traditional chants and songs, hindering the vocal support of fans. Additionally, there have been concerns for players and coaches who may find it difficult to communicate on the field due to the overpowering noise. Despite these debates, the vuvuzela remains an integral part of the soccer experience for many, reverberating with the passion and fervor of the devoted supporters.

Key pieces of information:

- a) The use of vuvuzelas has sparked controversy due to their excessive noise.
- b) Critics argue that the continuous buzzing can disrupt traditional forms of fan support.
- c) Concerns have been raised about communication difficulties for players and coaches due to the overpowering noise.

5. How does the sound of vuvuzelas affect players and referees during matches?

The distinctive sound of vuvuzelas has the potential to impact the concentration and communication abilities of players and referees on the field. Players may find it challenging to hear instructions from their teammates, coaches, and even the referee's whistle amid the cacophony of vuvuzelas. Referees, relying on verbal communication with players, may also encounter difficulties due to the overwhelming noise. However, it is worth noting that players and officials often adapt to these conditions, employing alternative communication methods such as visual cues or gestures to overcome the auditory obstacles posed by the vuvuzelas.

Key pieces of information:

- a) The sound of vuvuzelas can affect the concentration and communication of players and referees.
- b) Players may struggle to hear instructions and referee signals amid the noise.
- c) Visual cues and gestures are sometimes used as alternative communication methods in response to the auditory challenges posed by vuvuzelas.

In summary, the distinct sound heard at soccer matches is generated by the vuvuzela, a popular musical horn originating from South Africa. Its presence enhances the atmosphere by creating a continuous wall of sound that amplifies the energy of the crowd. While debates regarding their noise levels and impact on traditional forms of fan support exist, the vuvuzelas remain an integral part of the soccer experience, captivating audiences and adding an extra layer of excitement to matches. However, it is important to acknowledge that the loud buzzing of vuvuzelas may affect the concentration and communication abilities of players and referees on the field, requiring alternative methods of interaction amidst the auditory challenges.

## Conclusion

In conclusion, the soccer horn noise has become synonymous with the game and has its own importance and characteristics that affect both players and spectators. Its intermittent and intense sound has various effects on the soccer match atmosphere, team performance, and crowd engagement.

Firstly, the soccer horn noise creates a unique ambiance during soccer matches. Its distinctive sound serves as a constant reminder that one is witnessing a live game and adds a layer of excitement to the experience. The noise echoes throughout the stadium, creating an intense atmosphere that enhances the overall enjoyment of the event.

Secondly, the soccer horn noise can significantly impact player performance. The loud and sudden sound can startle and distract players on the field, affecting their concentration and focus. This interference may lead to a decrease in the quality of play, as players struggle to maintain their composure amidst the relentless noise.

Thirdly, the soccer horn noise also plays a crucial role in crowd engagement. Spectators often use these horns as a means of expressing their support for their team or voicing their frustrations. The rhythmic honking creates a synchronized chant-like effect that unifies the crowd and ignites a sense of camaraderie among fans.

Moreover, the soccer horn noise has received both praise and criticism. While some argue that it adds to the overall atmosphere and excitement, others feel that it can be excessive and disrupt the experience for both players and fans. The controversy surrounding the use of these horns has led to various regulations and restrictions in different soccer competitions and stadiums.

In conclusion, the soccer horn noise is an integral part of the soccer culture. Its unique sound contributes to the match atmosphere, impacts player performance, engages the crowd, and creates an unforgettable experience. Whether you love it or hate it, the soccer horn noise remains an emblem of the game, resonating within stadiums around the world.

[← Back to blog](#)

Milwaukee Train Horns

< 1 2 3 >

||

### Related Posts



#### [Top 10 Most Powerful Guns Worldwide: A Guide](#)

Did you know that some firearms have the ability to cause massive destruction with just a single shot? These powerful guns are capable of inflicting...



#### [Sports Horns: Amplifying Team Spirit and Energy](#)

One popular way for fans to show their support during sporting events is by utilizing loud noise-making devices. These items have been used for cen...



#### [Making a Statement: Unleash the Roar of Remote-Controlled Horn Guns in Public](#)

Picture this: a silent park, unsuspecting bystanders, and then BAM! The ear-splitting blast of a train horn gun shatters the calm. Welcome to the ...

## Latest blog posts

[View all](#)



### Birthday Parties: What Things Do You Blow?

FEBRUARY 28, 2024

Blow out candles and balloons at birthday parties - fun activities for all ages!



### What Are Squirrels Scared Of: Top Fears Revealed

FEBRUARY 28, 2024

What are squirrels scared of? Learn about common fears and how to keep them safe.



### What Are Horns Used For: Nature's Tools Explained

FEBRUARY 28, 2024

Horns are used for defense, mating rituals, and communication in various animals.

< 1/2 >

[View all](#)

[Search](#)

[Do not sell my personal information](#)

[Collections](#)

[Refund Policy](#)

[Privacy Policy](#)



© 2024, BossHorn Powered by Shopify



## Bolivar, Silvia A.

---

**From:** Pat Hauser <hdhauser@comcast.net>  
**Sent:** Wednesday, February 28, 2024 9:42 PM  
**To:** 'Jackie Fishman'; mgriffee@noreste.org; sec.dist4@gmail.com; edueweke@juno.com; kbbh@hotmail.com; ggarcia103@comcast.net; 'Maggie Rose'; anvanews@aol.com; 'Michael Haederle'; Pat Hauser  
**Cc:** 'Charlene Johnson'; brookemjordy@gmail.com; staylor@taylortowers.com; alamedamontoya@gmail.com; christinebnvdz@aol.com; 'Tina Villegas'; emyers\_11@yahoo.com; stemax1@aol.com; grumpyeh46@comcast.net; 'BARI Harvey'; 'Sandy Z'; Bolivar, Silvia A.; wbenson@berncoco.gov; Peggy Norton; Steve Wentworth  
**Subject:** RE: Meeting Notification - Balloon Fiesta Park / NM United Stadium  
**Attachments:** DOC036.pdf

**[EXTERNAL]** Forward to [phishing@cabq.gov](mailto:phishing@cabq.gov) and delete if an email causes any concern.

Good morning Ms. Fishman: For the record this would seem as if there is another RUSH and PUSH to get this meeting completed due to the short notice and timeframes just to get a box checked.

It would seem problematic to me and others that this process may leave many concerned and interested people and property owners inappropriate time to plan for such a meeting.

I believe that giving less than 3 business days' notice regarding a public facilitated meeting about the City of Albuquerque Land Use APPEAL NO.AC-23-22 is problematic and may not comply with appropriate notice for such a complex and long-lasting impact on the future of multiple property owners.

This should be held in an appropriate location such as the City Council chambers or the County Chambers as a neutral location. There is possible issue with some individuals not having access to the internet or personal commitments that may have been arranged prior to this short-rushed agenda meeting process.

In the past notification for an EPC meeting allows interested parties appropriate and ample time for planning and preparation. This does none of that.

It is also problematic that comments have been limited in time of 2 minutes. This issue being so complex needs a much better communication process regarding the Neighborhood Associations and the affected property owners.

Based on previous meetings and communication input from non-proximity parties is inconsequential as it relates to the direct and forever impact on, we nearby residents. It is basically in our backyards.

My suggestion and recommendation are to have the meeting scheduled on a weekend such as March 9, 2023 allowing proper planning for all affected parties.

Thus, allowing for PEOPLE, PROCESS, AND PROCEDURES to be sensitive to the issues and challenges at hand.

It would also seem appropriate to have the entire City of Albuquerque Balloon Fiesta Park Master Development Plan rewritten vs the current select editing for one specific request as outlined in your communication.

Awaiting a positive response regarding the critical need to reschedule this communication process.

Regards: Pat Hauser

---

**From:** Jackie Fishman <fishman@consensusplanning.com>  
**Sent:** Wednesday, February 28, 2024 7:22 PM  
**To:** mgriffee@noreste.org; sec.dist4@gmail.com; edueweke@juno.com; kbbh@hotmail.com; ggarcia103@comcast.net; Maggie Rose <gypsy.rose46@gmail.com>; hdhauser@comcast.net; anvanews@aol.com; Michael Haederle <haederle@yahoo.com>  
**Cc:** Charlene Johnson <Johnson@consensusplanning.com>; 'brookemjordy@gmail.com' <brookemjordy@gmail.com>;

'staylor@taylortowers.com' <staylor@taylortowers.com>; alamedamontoya@gmail.com; christinebnvdz@aol.com; Tina Villegas <t-marie-v@hotmail.com>; emyers\_11@yahoo.com; 'stemax1@aol.com' <stemax1@aol.com>; grumpyeh46@comcast.net; BARI Harvey <boyznbari@msn.com>; Sandy Z (szuschlag58@gmail.com) <szuschlag58@gmail.com>; Bolivar, Silvia A. <sabolivar@cabq.gov>

**Subject:** Meeting Notification - Balloon Fiesta Park / NM United Stadium

Ghdu#QhJkerw#

#

Wkh#sxusrvh#r#k#l#hp d#l#v#r#surygh#r#w#f#d#w#r#k#d#k#h#E#d#o#r#r#q#l#h#w#d#s#d#u#G#h#y#h#o#r#s#p#h#q#v#S#o#q#2#l#h#S#o#q#r#u#  
Vxegly#l#r#q#d#q#v#l#h#S#o#q#H#S#F#r#u#d#k#q#l#h#g#Q#h#z#P#h#{#f#r#v#r#f#h#u#v#d#g#k#p#z#d#v#h#p#d#q#g#h#g#r#k#h#I#q#y#l#r#q#p#h#q#v#d#S#o#q#q#l#j#  
F#r#p#p#l#v#l#r#q#H#S#F#e#|#k#h#D#d#q#g#K#v#h#K#h#d#u#l#j#R#i#f#h#u#O#X#K#R#,#r#o#r#z#l#j#d#l#q#l#s#s#h#d#e#|#g#n#f#h#q#v#h#l#j#k#e#r#k#r#g#  
d#v#r#f#d#w#r#q#v#D#v#s#d#u#e#|#k#h#h#p#d#q#g#k#h#F#l#|#r#D#e#x#t#x#h#u#t#x#h#v#h#q#y#l#j#j#h#l#j#k#e#r#k#r#g#d#v#r#f#d#w#r#q#v#d#q#g#h#l#j#k#e#r#w#r#d#  
i#d#f#d#w#h#g#p#h#h#w#j#j#r#g#l#v#x#v#v#k#h#h#t#x#h#w#h#

#

Wkh#d#f#d#w#h#g#p#h#h#w#j#j#l#e#h#k#h#g#r#q#P#r#q#g#d#|#P#d#u#f#k#7#/#5#3#5#7#/#u#r#p#B#-#6#3#r#:#-#6#3#p#|#J#h#s#u#h#v#h#q#v#d#y#h#v#h#u#r#p#k#h#F#l#|#  
r#D#e#x#t#x#h#u#t#x#h#d#q#g#Q#h#z#P#h#{#f#r#v#r#f#h#u#v#d#g#k#p#z#d#v#h#p#d#q#g#h#g#r#k#h#I#q#y#l#r#q#p#h#q#v#d#S#o#q#q#l#j#  
Wkh#p#h#h#w#j#j#l#e#h#d#f#d#w#h#g#e#|#d#F#l#|#E#r#q#w#d#f#w#r#d#q#g#k#h#g#r#q#d#h#y#d#r#r#j#d#P#h#h#w#k#v#l#j#j#k#h#d#q#n#e#h#o#r#z#|#  
#

p hhwjrrj d l frp 2(hf0x|fs0{hd#  
Mr l q#e|#skrqh#.#4#7470<3<06;97/#S#I#Q#.#39<98<:7#

#

Wkh#H#S#F#k#h#d#u#l#j#z#l#e#h#k#h#g#r#q#W#k#x#u#g#d#|#P#d#u#f#k#5#4#/#5#3#5#7#/#w#d#w#l#j#j#d#w#=#7#3#d#p#|#W#k#h#s#e#d#f#h#v#h#q#y#l#h#g#r#d#w#h#g#g#k#h#  
k#h#d#u#l#j#d#q#g#s#u#r#y#g#h#g#q#s#x#w#h#j#d#u#g#l#j#j#k#l#v#s#u#r#h#f#w#z#k#l#f#k#z#l#e#h#k#h#g#y#l#d#r#r#p#k#v#l#j#j#k#h#d#q#n#e#h#o#r#z#|#

#

[kwsv=2fdetj}rrp xv20559<8<5;8<#r#e|#E#d#o#q#j#k#h#r#o#r#z#l#j#q#x#p#e#h#.#1#6#3#4#:#.4#8#;8<5#d#q#g#h#q#v#h#u#l#j#P#h#h#w#j#j#](#)  
IG#559#8<#5;8<#

#

I#|#r#x#k#d#y#h#d#l#q#|#x#h#w#l#r#q#v#r#u#f#r#q#f#h#u#v#/#s#d#v#h#g#r#r#g#r#w#k#h#v#l#w#h#r#f#r#q#w#d#f#w#p#|#v#h#d#w#f#v#k#p#d#q#C#f#r#q#v#h#q#v#x#v#s#o#q#q#l#j#l#f#r#p#  
r#u#|#r#x#p#d#|#d#o#r#f#r#q#w#d#f#w#k#h#F#l#|#r#D#e#x#t#x#h#u#t#x#h#S#o#q#q#l#j#j#h#s#d#u#p#h#q#v#d#w#p#h#y#k#h#s#C#f#d#e#t#j#r#y#|#

#

V l qfhuhq /#

Miftxhdqh#l#k#p#d#q#/#D#I#F#S#  
Subqf#l#s#d#  
Frqvhqv#v#S#o#q#q#l#j#/#l#q#f#  
635#H#l#j#k#w#/#w#h#w#Q#Z#  
D#e#x#t#x#h#u#t#x#h#/#Q#P#:#:435#  
S#B#381:97k;34#

## Bolivar, Silvia A.

---

**From:** Peggy Norton <peggynorton@yahoo.com>  
**Sent:** Thursday, February 29, 2024 7:57 PM  
**To:** Baca, Vanessa  
**Cc:** 'Pat Hauser'; Hummell, Tyson; 'Philip Crump'; Flores, Suzanna A.; Bolivar, Silvia A.; 'Jackie Fishman'; Aranda, James M.; 'Cc: Maggie Rose'; 'Michael Haederle'; 'Steve Wentworth'; 'Evelyn Harris'; 'Brooke Jordy'; 'boyznbari@msn.com'; 'Sandy Zuschlag'; 'Steve Taylor'; 'Steve Horchheimer'; 'Edie Myers'; 't-marie-v@hotmail.com'; 'Christine Benavidez'; 'Lorraine Montoya'  
**Subject:** Re: Balloon Fiesta Park and NM United  
**Attachments:** NECA BYLAWS copy.pdf

[EXTERNAL] Forward to [phishing@cabq.gov](mailto:phishing@cabq.gov) and delete if an email causes any concern.

Here is the BernCo map I was using to determine boundaries of associations.

<https://ipgr.maps.arcgis.com/apps/webappviewer/index.html?id=e134233ba1fc4e92bd6133166fb9f6e2>

And I've attached a copy of North Edith Corridor's bylaws from 2001, which align with the BernCo map, and have not been updated officially.

Both of these indicate that the balloon park is within North Edith Corridor's boundaries. Maybe you could share the information used to draw the map you included.

I am pleased also to get your interpretation of NARO and it coincides with mine. That clears up that confusion. And I apologize to all those on this email who probably have no interest in this, but I don't want to drop off people now.

Thanks for your work on this, Vanessa and Michael.

Peggy Norton, President  
North Valley Coalition

On Thursday, February 29, 2024 at 06:50:54 PM MST, Peggy Norton <peggynorton@yahoo.com> wrote:

Thanks for your explanation, Vanessa. We are hoping to clarify the confusion between the map, the by laws, and what is actually considered.

Peggy Norton, President  
North Valley Coalition

On Thursday, February 29, 2024 at 04:53:48 PM MST, Baca, Vanessa <vanessabaca@cabq.gov> wrote:

Hi Peggy.

Thank you for your earlier e-mail inquiries regarding developer notice for the property at 5601 Balloon Fiesta Parkway.

The Neighborhood Association Recognition Ordinance (NARO) stipulates in Section §14-8-2-4 (B) (5) that for the purposes of notice, recognized neighborhood coalitions shall receive notice per the boundaries of member associations or groups only, and not for any individual members. In this particular case, the property site in question is within the boundaries of the Wildflower Neighborhood Association, which is itself a member of the District 4 Coalition. As such, both the Wildflower NA and the D4 Coalition received developer notice, as required by the Integrated Development Ordinance (IDO).

To address your specific question about the North Edith Commercial Corridor Association (NEC), the reason that the North Valley Coalition was not notified on behalf of NEC is because the property site in question is not adjacent to the eastern boundary of the NEC. The IDO defines adjacency as: those properties that are abutting or separated only by a street, alley, trail, or utility easement, whether public or private.

I have attached a map of the NEC boundaries that are on file with the Office of Neighborhood Coordination (ONC). As you can see demonstrated by the red outline, the eastern boundary of the NEC is Edith Boulevard. The properties which are adjacent to the subject site are not within the boundaries of the NEC, nor is the subject site within the boundaries of the NEC.

Please let me know if you need additional information.



**Vanessa Baca**

Manager

Office of Neighborhood Coordination (ONC) | City Council Department | City of Albuquerque

(505) 768-3331 Office

E-mail: [vanessabaca@cabq.gov](mailto:vanessabaca@cabq.gov)



---

**From:** Peggy Norton <peggynorton@yahoo.com>  
**Sent:** Thursday, February 29, 2024 1:18 PM  
**To:** Pat Hauser <hdhauser@comcast.net>; Hummell, Tyson <thummell@cabq.gov>; Philip Crump <phcrumpsf@gmail.com>; Flores, Suzanna A. <SuzannaFlores@cabq.gov>; Bolivar, Silvia A. <sabolivar@cabq.gov>; Jackie Fishman <fishman@consensusplanning.com>; Aranda, James M. <jmaranda@cabq.gov>  
**Cc:** Maggie Rose <gypsy.rose46@gmail.com>; Michael Haederle <haederle@yahoo.com>; Steve Wentworth <anvanews@aol.com>; Evelyn Harris <grumpyeh46@comcast.net>; Brooke Jordy <brookemjordy@gmail.com>; boyznbari@msn.com; Sandy Zuschlag <szuschlag58@gmail.com>; Steve Taylor <staylor@taylortowers.com>; 'Steve Horchheimer' <stemax1@aol.com>; 'Edie Myers' <emyers\_11@yahoo.com>; t-marie-v@hotmail.com; Christine Benavidez <christinebnvdz@aol.com>; 'Lorraine Montoya' <alamedamontoya@gmail.com>  
**Subject:** Re: Balloon Fiesta Park and NM United

**[EXTERNAL]** Forward to [phishing@cabq.gov](mailto:phishing@cabq.gov) and delete if an email causes any concern.

Thanks James. I have a call in to ONC and I see Suzanna is on this email. The NARO is clear in defining Coalition membership: recognized neighborhood associations, neighborhood associations, homeowner associations, etc. (Page 8). Note that recognized NA's and NA's are two separate entities. Recognized neighborhood coalitions shall receive notices per the boundaries of member associations or groups only, and not for any individual members. (Page 9). Nothing requires the member associations or groups to be recognized, and obviously groups do not have that pathway. North Edith Corridor is a member of the Coalition and we should be included in notification.

Peggy Norton, President

North Valley Coalition

On Thursday, February 29, 2024 at 11:57:15 AM MST, Aranda, James M. <[jmaranda@cabq.gov](mailto:jmaranda@cabq.gov)> wrote:

Peggy,

Much thanks for reaching out regarding this matter. After previously discussing the matter with Legal, my understanding of the notice requirements is that neighborhood coalitions are only notified if there is a recognized neighborhood association within the coalition boundaries.

As with all EPC cases, the Office of Neighborhood Coordination determines which associations and coalitions are required to be notified. According to the public record associated with the request, the North Valley Coalition was not included on the original notification list, nor was NVC included on the most current notification list. My understanding as to why NVC was not notified is because there were no recognized neighborhood associations within the notification area that are part of NVC.

Please be aware that while the ZEO is responsible for interpreting the provisions of the IDO, I do not have the authority to establish notification boundaries or requirements, nor do I have the authority to interpret NARO's provisions. This being the case, I recommend discussing NARO's notification requirements with ONC staff and leadership. I apologize for any confusion or inconvenience.

Respectfully,

JMA

**JAMES M. ARANDA, MCRP**

deputy director + zeo

505-924-3361

[jmaranda@cabq.gov](mailto:jmaranda@cabq.gov)

[cabq.gov/planning](http://cabq.gov/planning)

---

**From:** Peggy Norton <[peggynorton@yahoo.com](mailto:peggynorton@yahoo.com)>

**Sent:** Thursday, February 29, 2024 11:08 AM

**To:** Pat Hauser <[hdhauser@comcast.net](mailto:hdhauser@comcast.net)>; Hummell, Tyson <[thummell@cabq.gov](mailto:thummell@cabq.gov)>; Philip Crump <[phcrumpsf@gmail.com](mailto:phcrumpsf@gmail.com)>; Flores, Suzanna A. <[Suzannaflores@cabq.gov](mailto:Suzannaflores@cabq.gov)>; Aranda, James M. <[jmaranda@cabq.gov](mailto:jmaranda@cabq.gov)>; Bolivar, Silvia A. <[sabolivar@cabq.gov](mailto:sabolivar@cabq.gov)>; Jackie Fishman <[fishman@consensusplanning.com](mailto:fishman@consensusplanning.com)>

**Cc:** Maggie Rose <[gypsy.rose46@gmail.com](mailto:gypsy.rose46@gmail.com)>; Michael Haederle <[haederle@yahoo.com](mailto:haederle@yahoo.com)>; Steve Wentworth <[anvanews@aol.com](mailto:anvanews@aol.com)>; Evelyn Harris <[grumpyeh46@comcast.net](mailto:grumpyeh46@comcast.net)>; Brooke Jordy <[brookemjordy@gmail.com](mailto:brookemjordy@gmail.com)>; boyznbari@msn.com; Sandy Zuschlag <[szuschlag58@gmail.com](mailto:szuschlag58@gmail.com)>; Steve Taylor <[staylor@taylortowers.com](mailto:staylor@taylortowers.com)>; 'Steve Horchheimer' <[stemax1@aol.com](mailto:stemax1@aol.com)>; 'Edie Myers' <[emyers\\_11@yahoo.com](mailto:emyers_11@yahoo.com)>; t-marie-v@hotmail.com; Christine Benavidez <[christinebnvdz@aol.com](mailto:christinebnvdz@aol.com)>; 'Lorraine Montoya' <[alamedamontoya@gmail.com](mailto:alamedamontoya@gmail.com)>

**Subject:** Re: Balloon Fiesta Park and NM United

**[EXTERNAL]** Forward to [phishing@cabq.gov](mailto:phishing@cabq.gov) and delete if an email causes any concern.

I looked further into this and I will be communicating with Suzanna and James. My interpretation of NARO requires us to be notified.

Peggy Norton, President  
North Valley Coalition

On Wednesday, February 28, 2024 at 07:12:33 PM MST, Jackie Fishman <[fishman@consensusplanning.com](mailto:fishman@consensusplanning.com)> wrote:

Thanks for getting back to us.



**Jacqueline Fishman, AICP**

Principal  
Consensus Planning, Inc.  
302 Eighth Street NW  
Albuquerque, NM 87102  
P: 505.764.9801

---

**From:** Peggy Norton <[peggynorton@yahoo.com](mailto:peggynorton@yahoo.com)>

**Sent:** Wednesday, February 28, 2024 6:55 PM

**To:** Pat Hauser <[hdhauser@comcast.net](mailto:hdhauser@comcast.net)>; [thummell@cabq.gov](mailto:thummell@cabq.gov); Philip Crump <[phcrumpsf@gmail.com](mailto:phcrumpsf@gmail.com)>; [suzannaflores@cabq.gov](mailto:suzannaflores@cabq.gov); Aranda, James M. <[jmaranda@cabq.gov](mailto:jmaranda@cabq.gov)>; Bolivar, Silvia A. <[sabolivar@cabq.gov](mailto:sabolivar@cabq.gov)>; Jackie Fishman <[fishman@consensusplanning.com](mailto:fishman@consensusplanning.com)>

**Cc:** Maggie Rose <[gypsy.rose46@gmail.com](mailto:gypsy.rose46@gmail.com)>; Michael Haederle <[haederle@yahoo.com](mailto:haederle@yahoo.com)>; Steve Wentworth <[anvanews@aol.com](mailto:anvanews@aol.com)>; Evelyn Harris <[grumpyeh46@comcast.net](mailto:grumpyeh46@comcast.net)>; Brooke Jordy <[brookemjordy@gmail.com](mailto:brookemjordy@gmail.com)>; [boyznbari@msn.com](mailto:boyznbari@msn.com); Sandy Zuschlag <[szuschlag58@gmail.com](mailto:szuschlag58@gmail.com)>; Steve Taylor <[staylor@taylortowers.com](mailto:staylor@taylortowers.com)>; 'Steve Horchheimer' <[stemax1@aol.com](mailto:stemax1@aol.com)>; 'Edie Myers' <[emyers\\_11@yahoo.com](mailto:emyers_11@yahoo.com)>; [t-marie-v@hotmail.com](mailto:t-marie-v@hotmail.com); Christine Benavidez <[christinebnvdz@aol.com](mailto:christinebnvdz@aol.com)>; 'Lorraine Montoya' <[alamedamontoya@gmail.com](mailto:alamedamontoya@gmail.com)>

**Subject:** Re: Balloon Fiesta Park and NM United

I checked a couple boundaries and they are correct to omit us.

Peggy Norton, President  
North Valley Coalition

On Wednesday, February 28, 2024 at 05:42:20 PM MST, Jackie Fishman <[fishman@consensusplanning.com](mailto:fishman@consensusplanning.com)> wrote:

Ms. Norton –

Thanks for your email. The Office of Neighborhood Coordination determines which associations and coalitions are required to be notified – the NVC was not included on the original list or the most current list. I've copied Susie Flores (ONC) and James Aranda (ZEO) on this email and you are welcome to discuss your concern about notification to the NVC with both of them.

**Jacqueline Fishman, AICP**

Principal  
Consensus Planning, Inc.  
302 Eighth Street NW  
Albuquerque, NM 87102  
P: 505.764.9801

---

**From:** Peggy Norton <[peggynorton@yahoo.com](mailto:peggynorton@yahoo.com)>

**Sent:** Wednesday, February 28, 2024 5:29 PM

**To:** Jackie Fishman <[fishman@consensusplanning.com](mailto:fishman@consensusplanning.com)>; Pat Hauser <[hdhauser@comcast.net](mailto:hdhauser@comcast.net)>; [thummell@cabq.gov](mailto:thummell@cabq.gov); Philip Crump <[phcrumpsf@gmail.com](mailto:phcrumpsf@gmail.com)>

**Cc:** Maggie Rose <[gypsy.rose46@gmail.com](mailto:gypsy.rose46@gmail.com)>; Michael Haederle <[haederle@yahoo.com](mailto:haederle@yahoo.com)>; Steve Wentworth <[anvanews@aol.com](mailto:anvanews@aol.com)>; Evelyn Harris <[grumpyeh46@comcast.net](mailto:grumpyeh46@comcast.net)>; Brooke Jordy <[brookemjordy@gmail.com](mailto:brookemjordy@gmail.com)>; [boyznbari@msn.com](mailto:boyznbari@msn.com); Sandy Zuschlag <[szuschlag58@gmail.com](mailto:szuschlag58@gmail.com)>; Steve Taylor <[staylor@taylortowers.com](mailto:staylor@taylortowers.com)>; 'Steve Horchheimer' <[stemax1@aol.com](mailto:stemax1@aol.com)>; 'Edie Myers' <[emyers\\_11@yahoo.com](mailto:emyers_11@yahoo.com)>; [t-marie-v@hotmail.com](mailto:t-marie-v@hotmail.com); Christine

Benavidez <[christinebnvdz@aol.com](mailto:christinebnvdz@aol.com)>; 'Lorraine Montoya' <[alamedamontoya@gmail.com](mailto:alamedamontoya@gmail.com)>

**Subject:** Re: Balloon Fiesta Park and NM United

As a coalition representative who never received notice on the first round, I would like to comment on this. I have not read the remand order from the Land Use Hearing Officer, but evidently, the legally required notification was lacking. I am hoping we will be included in this round, but I am not sure of that. Giving less than 5 days notice for a public facilitated meeting about the soccer stadium hardly seems to comply with appropriate notice. Generally, notification for an EPC meeting allows interested parties 15 days to request a meeting. Perhaps this remand order negated that requirement. I am a little behind in this case and will look for the remand order, but I wanted to get these comments in. Additionally, Monday is a City Council meeting.

Peggy Norton, President  
North Valley Coalition

On Wednesday, February 28, 2024 at 02:30:59 PM MST, Philip Crump <[phcrumpsf@gmail.com](mailto:phcrumpsf@gmail.com)> wrote:

Thank you, Jackie and Pat.

I can send a Google Meet invitation for Monday the 4th, starting at 5:30, for two hours.

Is that agreeable?

Respectfully,  
Philip



**PHILIP CRUMP, Mediator & Facilitator**

1301 Luisa Street Santa Fe, New Mexico 87505

[www.pcmediate.com](http://www.pcmediate.com) Txt/VM: (505) 989-8558

*When I walked out of the gate, I knew that if I continued to hate these people, I would still be in prison. --Nelson Mandela*

On 2/28/2024 2:04 PM, Jackie Fishman wrote:

Pat –

I agree that the meeting shouldn't be during the day as that would prevent working people from participating. The meeting would be via Zoom and in the evening.

I spoke with Brooke this morning and proposed this coming Monday evening for the facilitated meeting. She was agreeable to that date and so I have notified our team. I'm hoping that is agreeable to you as well.

Our intent is to be back in front of the EPC for the March 21<sup>st</sup> hearing. We are gearing up this afternoon to start sending out notifications today. The representatives from the City recognized associations, as well as representatives from the County neighborhood associations, will be receiving an official email notification today from my office. We are also sending out certified mail notices to all property owners within the 100-foot buffer; that list has been vetted and confirmed with the Planning Department's GIS Manager. We are also sending first class mail to the other property owners that were on your map, everyone who attended any of the seven meetings that provided a mailing address, and every address along the east side of Edith. Parks and Rec will be going door to door with copies of the notice as well. This means some people will likely get 2 or 3 notices in our effort.

I suspect the main agenda item is going to be sound. Let me know if there are specific other items that you would like our team to address.

Please feel free to give me a call to discuss.

**Jacqueline Fishman, AICP**

Principal

Consensus Planning, Inc.

302 Eighth Street NW

Albuquerque, NM 87102

---

**From:** Pat Hauser <[hdhauser@comcast.net](mailto:hdhauser@comcast.net)>  
**Sent:** Wednesday, February 28, 2024 11:50 AM  
**To:** Jackie Fishman <[fishman@consensusplanning.com](mailto:fishman@consensusplanning.com)>  
**Cc:** Maggie Rose <[gypsy.rose46@gmail.com](mailto:gypsy.rose46@gmail.com)>; Michael Haederle <[haederle@yahoo.com](mailto:haederle@yahoo.com)>; Steve Wentworth <[Anvanews@aol.com](mailto:Anvanews@aol.com)>; Peggy Norton <[peggynorton@yahoo.com](mailto:peggynorton@yahoo.com)>; Evelyn Harris <[grumpyeh46@comcast.net](mailto:grumpyeh46@comcast.net)>; Brooke Jordy <[brookemjordy@gmail.com](mailto:brookemjordy@gmail.com)>; [boyznbari@msn.com](mailto:boyznbari@msn.com); Sandy Zuschlag <[szuschlag58@gmail.com](mailto:szuschlag58@gmail.com)>; Steve Taylor <[staylor@taylortowers.com](mailto:staylor@taylortowers.com)>; 'Steve Horschheimer' <[stemax1@aol.com](mailto:stemax1@aol.com)>; 'Edie Myers' <[emyers\\_11@yahoo.com](mailto:emyers_11@yahoo.com)>; [t-marie-v@hotmail.com](mailto:t-marie-v@hotmail.com); Christine Benavidez <[christinebnvdz@aol.com](mailto:christinebnvdz@aol.com)>; 'Lorraine Montoya' <[alamedamontoya@gmail.com](mailto:alamedamontoya@gmail.com)>  
**Subject:** RE: Balloon Fiesta Park and NM United

Good morning Ms. Fishman: Thanks for the message regarding the proposed meeting. Your telephone number was blocked on my cellphone as a potential Spam number.

Not sure why maybe since you are not in my contact list.

Based on my limited knowledge regarding the meeting it would seem as if it is being planned as a Zoom or something of that nature.

My experience has been that if such a meeting is conducted during the day it seriously hampers many individuals from attending due to their business or work schedules.

I would like to contact several of the other Associations and get their input regarding a possible best time to proceed with such a meeting.

It would also be helpful to know the agenda items and what is planned for possible discussion items that will impact we the property owners.

I have taken the liberty to copy several individuals in on our communication regarding a proposed meeting.

Thanks in advance for working with us on this subject.

Regards: Pat Hauser

---

**From:** Jackie Fishman <[fishman@consensusplanning.com](mailto:fishman@consensusplanning.com)>  
**Sent:** Wednesday, February 28, 2024 8:51 AM  
**To:** [hdhauser@comcast.net](mailto:hdhauser@comcast.net)  
**Cc:** [gypsy.rose46@gmail.com](mailto:gypsy.rose46@gmail.com); [phcrumpsf@gmail.com](mailto:phcrumpsf@gmail.com)  
**Subject:** Balloon Fiesta Park and NM United  
**Importance:** High

Hi Pat –

I left you a voicemail yesterday in regard to the EPC remand. We would like to schedule a meeting to discuss the project and I've copied the meeting facilitator. We are working on notification and have greatly expanded the list of who we will be sending notification to. Given the number of associations and individuals involved, I would like to work with you to pick a meeting date next week and then my office will add the date to the notification. Could you or Maggie please either email me back or call me to discuss your availability next week?

Thanks, and hope to hear from you soon.

**Jacqueline Fishman, AICP**  
Principal  
Consensus Planning, Inc.  
302 Eighth Street NW  
Albuquerque, NM 87102  
P: 505.764.9801

**From:** [Peggy Norton](#)  
**To:** [Bolivar, Silvia A.](#); [Planning EPC](#)  
**Cc:** [Pat Hauser](#); [Michael Haederle](#)  
**Subject:** remand letter  
**Date:** Sunday, March 10, 2024 8:34:20 PM  
**Attachments:** [soccer stadium - epc comments2.pdf](#)  
[NECA BYLAWS copy.pdf](#)

---

**[EXTERNAL]** Forward to [phishing@cabq.gov](mailto:phishing@cabq.gov) and delete if an email causes any concern.

Dear Ms. Bolivar:

Attached are comments to be included in the staff report for the remand hearing of the NM United soccer stadium. I also attach a copy of North Edith Corridor Association bylaws which include their stated boundaries. Please confirm receipt.

Thank you.

Peggy Norton, President  
North Valley Coalition

March 10, 2024

I am submitting comments regarding the EPC case for the United NM Soccer Stadium. The North Valley Coalition requests that this hearing be deferred until all remand guidelines are followed.

1. As President of the North Valley Coalition (NVC), I researched the remand notice from the Land Use Hearing Officer. We weren't notified on the first round. Since proper notification was the only reason for the remand, I looked into the issue. North Edith Corridor Association (NECA) is a member of the Coalition, and any notification they receive for projects within their boundaries, we should receive, per the Neighborhood Association Recognition Ordinance (NARO). Both the County boundary maps and NECA bylaws from 2001 indicate the Balloon Park is within the boundaries of NECA and within the boundaries of the Coalition. I asked Jackie Fishman from Consensus Planning about notification and was advised that the Office of Neighborhood Coordination (ONC) had not included us on the notification list.

I contacted Vanessa Baca at ONC and was advised that they have consistently used other boundaries for the North Edith Corridor Association. Rather than making a notification correction to comply with this important remand, I was advised that NECA will need to amend their current on-file boundaries. However, it would seem that their current on-file boundaries should be determined from their bylaws; an important part of bylaws is stating boundaries to be used by ONC. This lack of notification to the North Valley Coalition constitutes non-compliance with the remand. Why am I concerned about this error? After all, I was able to send notice to our email list on Sunday, the day before the facilitated meeting. However, due to lack of required notification on a different case, we now have an asphalt plan at Carmony and Alexander. This error was not discovered until the asphalt plant equipment was installed. Thus, there are consequences for lack of notification and sometimes they are not known until a project happens.

2. The remand notice states: Notice shall be fully accomplished as required under the IDO; in areas in which the edge of that 100-foot buffer falls within any public right-of-way, adjacent properties will be included in the notice. A semi-colon separates two independent parts of a sentence. I would interpret this to mean that the IDO requirements for notification of an EPC meeting need to be met. The second part clarifies what was an issue in the appeal to assure that it is included in the notification process. The remand also indicates that there could be possibly more than 9 property owners affected. The IDO requires a letter or email notification of the meeting be sent and a sign to be posted on the property. However, it also allows neighborhood associations a defined time to request a facilitated meeting. The IDO allows them 15 days from notification to do this and then a meeting scheduled between 15 and 30 days after that. Planning determined that this requirement did not need to be met. A facilitated meeting was hastily scheduled by the agent and gave people 5 days notice at the most. A justification for the time allowed is for associations to notify members. The Planning Department erred in interpreting the

remand request to be only a return to the EPC and not requiring all the IDO rules for EPC hearings, including timelines, be met.

Peggy Norton, President  
North Valley Coalition



# NEIGHBORHOOD ASSOCIATION BY-LAWS

## Article I- Name

The name of the association shall be the North Edith Corridor Association .

## Article II - Purpose

The purpose of the Association shall be to oversee and foster the orderly commercial corridor and assist with other existing organizations, in resource conservation during the sustained growth pattern in the forthcoming generation, bound by the North to the Sandia Reservation, bound by the South to Candelaria, bound by the East to I-25, and bound by the West by the Rail Road tracks.

## Article III - Membership

Section 1. Membership shall be open to all persons residing within the boundaries and to all persons and legal entities owning property or having a place of business within the boundaries.

Section 2. Each paid membership shall be entitled to one vote.

Section 3. Annual dues will be \$250.00 for each Business member, and \$100.00 for each resident member. Special assessments may be fixed by a majority vote of the Board of Directors for reasons they deem necessary.

Section 4. The Association shall conduct an annual enrollment of members in the month of July. New membership shall be available at any time. Membership expires the last day of July.

## Article IV - Directors and Officers

Section 1. A Board of Directors consisting of three members shall be the governing body of the Association and shall be elected by the Association's general membership at the annual meeting.

Section 2. Officers of the Association shall be a President, Vice President, Secretary-Treasurer.

Section 3. The term of office for the President, Vice President, Secretary-Treasurer shall be for (1) one year.

Section 4. Only members of the Board of Directors shall be eligible to be officers of the Association.

Section 5. Vacancies occurring in any office shall be filled for the unexpired term by a majority vote of the Board of Directors.

Section 6. Any elected officer or board member may be removed from office by a majority membership, whenever, in its judgment, the best interest of the Association would be served thereby.

Section 7. Nominations for the Board may be submitted by any member of the Association seven days in advance of the annual meeting.

#### Article V - Duties of the Officers

The duties of the officers shall include but not limited to the following:

Section 1. **PRESIDENT:** The President shall be the chief executive officer of the Association and shall in general supervise all the business and affairs of the association between the meetings of the Board of Directors. The president shall preside at all meetings of the Board of Directors and the general membership. The president shall, with the approval of the Board of Directors, appoint all standing and special committees except the nominating Committee, and shall be Ex-Officio member of all the committees except the nominating committee. The president shall make an annual report to the general membership at the annual meeting and file such report with the secretary. The president shall make all necessary reports to the City and County in compliance with the Neighborhood Association Recognition Ordinance.

Section 2. **VICE PRESIDENT:** The vice president shall when necessary, perform the duties of the president, and shall succeed to the presidency in the event of death, disability, removal from office or resignation of the president until such time as a successor to the president shall be elected.

Section 3. **SECRETARY:** The secretary shall keep minutes of all meetings of the board of directors and of the general membership and shall keep all records of the association and give notice of all meetings as directed. The secretary shall perform all duties incident to the office of the secretary or as

may be required by the president or the board of directors.

Section 4. TREASURER: The treasurer shall collect all money due the association and shall have custody of all funds of the association, pay all bills approved by the board of directors, keep account of all receipts and expenditures. The treasurer shall present a financial statement at each board of directors and general meetings.

#### Article VI - Committees

Section 1. The membership may establish necessary committees at any meeting. The president may also establish such committees. Committee chairpersons shall be appointed by the president.

2. No report or other action of any committee or any officer of the association shall be considered as the act of the association unless and until it has been approved by the board of directors or by the general membership whenever possible.

#### Article VII - Meetings

Section 1. The annual meeting of the members shall be held on the second Thursday of July of each year at 7:00 PM unless otherwise determined by the board of directors. The annual board of directors meeting shall be held immediately thereafter.

Section 2. The annual meeting shall be for the purpose of electing board members, receiving annual reports of officers and committees and other business as determined by the board.

Section 3. Notice of the annual meeting shall be given to all residents and businesses by flyer, mail or a prominently posted sign. No election can be held at a meeting unless so advertised.

Section 4. All votes shall be decided by a majority of the members present at any meeting provided that a quorum is present.

Section 5. The board of directors has the option of requiring written ballots with proof of membership in the association.

Article VIII - Dissolution

In the event of dissolution of the association, the board of directors shall, after payment of all liabilities of the association, dispose of the remaining assets of the association by donating the money to a charity as deemed appropriate by the then governing officers of the corporation.

Article IX - Amendments

The by-laws may be amended at any regular or special meeting of the general membership by two-thirds (2/3) vote of those in attendance, provided that the membership has been notified ten days in advance of the meeting that amendments will be entertained at that meeting.

I certify that the foregoing by-laws were adopted and ratified by the members of the NORTH EDITH CORRIDOR ASSOCIATION on the 26th day of July, 2001 and adopted and ratified by the board of directors at a meeting held on the 26th day of July, 2001.

George W. W. W.  
President

Jane C. C.  
Secretary

I would like to express opposition to the current plan for NM United Soccer Stadium. The facilitated meeting on March 4, 2024 was my first experience in hearing plans. I respected the comments of the neighbors and feel they have some very valid concerns that are not being addressed. A Management Plan is a guiding document, written after much collaboration and compromise with representation from a diversity of interested parties. I assume the banning of an outdoor stadium was an important item and should be honored as such. Due to the conditions in the lease, the impacts of the proposed stadium to nearby citizens will be huge. This is not an urban area - it is agricultural, rural.

I have always loved the Balloon Fiesta and appreciated and admired the civic responsibility accepted by nearby citizens to allow this wonderful, international event to take place. I can see the efforts put forth to minimize impacts of traffic and noise - some successful and some not. These efforts will not happen at the many events being possible at the stadium. Most people I talk to think that 17 soccer games is not a big deal, what are people complaining about. They don't understand the possibilities of the lease, and the impacts. Mitigation efforts have been suggested and some completed in the design. The owner agreed to being willing to discuss others, but these should be agreed to in writing before any approval is completed. One suggestion was banning fireworks - I have dogs and would not want them fearful during many possible fireworks displays. The citizens suggested a roof as a mitigation possibility but I did not hear any serious consideration of that - just mention of a possible \$100,000,000 cost. No thought was given to a variety of options to accomplish that.

This stadium started with a feasibility study by FBT Architects as a venue for 5,000; it is now for 20,000. The team had a turnout of almost 11,500 for the March 9 game and a fan base that continues to grow. That is exciting. Surely, there are other sites that would be more appropriate - there is no reason to rush this. It would seem that the stadium area around south University Blvd. which seems to accommodate the games now or even further south would be a better option. Negotiation with politically powerful people can accomplish a lot. Please be respectful of the citizen input and consider other locations.

Peggy Norton  
3810 11<sup>th</sup> Street NW  
Albuquerque, NM 87107

**From:** [Peggy Norton](#)  
**To:** [Bolivar, Silvia A.](#)  
**Cc:** [Pat Hauser](#); [Michael Haederle](#)  
**Subject:** remand  
**Date:** Monday, March 11, 2024 8:26:03 AM

---

**[EXTERNAL]** Forward to [phishing@cabq.gov](mailto:phishing@cabq.gov) and delete if an email causes any concern.

Dear Ms. Bolivar: Please include these additional comments for the EPC hearing on the soccer stadium.

*As I noted in an earlier letter, this project should be located at a different site due to the fact that the negative effects of sound including fireworks, lights, traffic, etc. cannot be mitigated the way the project is planned. This area already is impacted by the Balloon Fiesta, having to alter their lives for 10 days. There are several other big events occurring at the park as well as people and sports teams using the numerous open space. I didn't hear the residents objecting to these uses. What they are objecting to is adding an entirely new aspect to the park. This violates Goal 5.3.7 of the Comprehensive Plan:*

***Goal 5.3.7 Locally Unwanted Land Uses:*** *Ensure that land uses that are objectionable to immediate neighbors but may be useful to society are located carefully and equitably to ensure that social assets are distributed evenly and social responsibilities are borne fairly across the Albuquerque area.*

*Peggy Norton*

Thank you.



**From:** [Jackie Fishman](#)  
**To:** [Peggy Norton](#); [Pat Hauser](#); [Hummell, Tyson](#); [Philip Crump](#); [Flores, Suzanna A.](#); [Aranda, James M.](#); [Bolivar, Silvia A.](#)  
**Cc:** [Maggie Rose](#); [Michael Haederle](#); [Steve Wentworth](#); [Evelyn Harris](#); [Brooke Jordy](#); [boyznbari@msn.com](#); [Sandy Zuschlag](#); [Steve Taylor](#); "Steve Horchheimer"; "Edie Myers"; [t-marie-v@hotmail.com](#); [Christine Benavidez](#); "Lorraine Montoya"  
**Subject:** RE: Balloon Fiesta Park and NM United  
**Date:** Wednesday, February 28, 2024 7:12:39 PM  
**Attachments:** [image001.png](#)

---

[EXTERNAL] Forward to [phishing@cabq.gov](mailto:phishing@cabq.gov) and delete if an email causes any concern.

Thanks for getting back to us.

Jacqueline Fishman, AICP  
Principal  
Consensus Planning, Inc.  
302 Eighth Street NW  
Albuquerque, NM 87102  
P: 505.764.9801

---

**From:** Peggy Norton <[peggynorton@yahoo.com](mailto:peggynorton@yahoo.com)>  
**Sent:** Wednesday, February 28, 2024 6:55 PM  
**To:** Pat Hauser <[hdhauser@comcast.net](mailto:hdhauser@comcast.net)>; [thummell@cabq.gov](mailto:thummell@cabq.gov); Philip Crump <[phcrumpsf@gmail.com](mailto:phcrumpsf@gmail.com)>; [suzannaflores@cabq.gov](mailto:suzannaflores@cabq.gov); Aranda, James M. <[jmaranda@cabq.gov](mailto:jmaranda@cabq.gov)>; Bolivar, Silvia A. <[sabolivar@cabq.gov](mailto:sabolivar@cabq.gov)>; Jackie Fishman <[fishman@consensusplanning.com](mailto:fishman@consensusplanning.com)>  
**Cc:** Maggie Rose <[gypsy.rose46@gmail.com](mailto:gypsy.rose46@gmail.com)>; Michael Haederle <[haederle@yahoo.com](mailto:haederle@yahoo.com)>; Steve Wentworth <[anvanews@aol.com](mailto:anvanews@aol.com)>; Evelyn Harris <[grumpyeh46@comcast.net](mailto:grumpyeh46@comcast.net)>; Brooke Jordy <[brookemjordy@gmail.com](mailto:brookemjordy@gmail.com)>; [boyznbari@msn.com](mailto:boyznbari@msn.com); Sandy Zuschlag <[szuschlag58@gmail.com](mailto:szuschlag58@gmail.com)>; Steve Taylor <[staylor@taylortowers.com](mailto:staylor@taylortowers.com)>; 'Steve Horchheimer' <[stemax1@aol.com](mailto:stemax1@aol.com)>; 'Edie Myers' <[emyers\\_11@yahoo.com](mailto:emyers_11@yahoo.com)>; [t-marie-v@hotmail.com](mailto:t-marie-v@hotmail.com); Christine Benavidez <[christinebnvdz@aol.com](mailto:christinebnvdz@aol.com)>; 'Lorraine Montoya' <[alamedamontoya@gmail.com](mailto:alamedamontoya@gmail.com)>  
**Subject:** Re: Balloon Fiesta Park and NM United

I checked a couple boundaries and they are correct to omit us.

Peggy Norton, President  
North Valley Coalition

On Wednesday, February 28, 2024 at 05:42:20 PM MST, Jackie Fishman <[fishman@consensusplanning.com](mailto:fishman@consensusplanning.com)> wrote:

Ms. Norton –

Thanks for your email. The Office of Neighborhood Coordination determines which associations and coalitions are required to be notified – the NVC was not included on the original list or the most current list. I've copied Susie Flores (ONC) and James Aranda (ZEO) on this email and you are welcome to discuss your concern about notification to the NVC with both of them.

**Jacqueline Fishman, AICP**

Principal

Consensus Planning, Inc.

302 Eighth Street NW

Albuquerque, NM 87102

P: 505.764.9801

---

**From:** Peggy Norton <[peggynorton@yahoo.com](mailto:peggynorton@yahoo.com)>  
**Sent:** Wednesday, February 28, 2024 5:29 PM  
**To:** Jackie Fishman <[fishman@consensusplanning.com](mailto:fishman@consensusplanning.com)>; Pat Hauser <[hdhauser@comcast.net](mailto:hdhauser@comcast.net)>; [thummell@cabq.gov](mailto:thummell@cabq.gov); Philip Crump <[phcrumpsf@gmail.com](mailto:phcrumpsf@gmail.com)>  
**Cc:** Maggie Rose <[gypsy.rose46@gmail.com](mailto:gypsy.rose46@gmail.com)>; Michael Haederle <[haederle@yahoo.com](mailto:haederle@yahoo.com)>; Steve Wentworth <[anvanews@aol.com](mailto:anvanews@aol.com)>; Evelyn Harris <[grumpyeh46@comcast.net](mailto:grumpyeh46@comcast.net)>; Brooke Jordy <[brookemjordy@gmail.com](mailto:brookemjordy@gmail.com)>; [boyznbari@msn.com](mailto:boyznbari@msn.com); Sandy Zuschlag <[szuschlag58@gmail.com](mailto:szuschlag58@gmail.com)>; Steve Taylor <[staylor@taylortowers.com](mailto:staylor@taylortowers.com)>; 'Steve Horchheimer' <[stemax1@aol.com](mailto:stemax1@aol.com)>; 'Edie Myers' <[emyers\\_11@yahoo.com](mailto:emyers_11@yahoo.com)>; [t-marie-v@hotmail.com](mailto:t-marie-v@hotmail.com); Christine Benavidez <[christinebnvdz@aol.com](mailto:christinebnvdz@aol.com)>; 'Lorraine Montoya' <[alamedamontoya@gmail.com](mailto:alamedamontoya@gmail.com)>  
**Subject:** Re: Balloon Fiesta Park and NM United

As a coalition representative who never received notice on the first round, I would like to comment on this. I have not read the remand order from the Land Use Hearing Officer, but evidently, the legally required notification was lacking. I am hoping we will be included in this round, but I am not sure of that. Giving less than 5 days notice for a public facilitated meeting about the soccer stadium hardly seems to

comply with appropriate notice. Generally, notification for an EPC meeting allows interested parties 15 days to request a meeting. Perhaps this remand order negated that requirement. I am a little behind in this case and will look for the remand order, but I wanted to get these comments in. Additionally, Monday is a City Council meeting.

Peggy Norton, President

North Valley Coalition

On Wednesday, February 28, 2024 at 02:30:59 PM MST, Philip Crump <[phcrumpsf@gmail.com](mailto:phcrumpsf@gmail.com)> wrote:

Thank you, Jackie and Pat.

I can send a Google Meet invitation for Monday the 4th, starting at 5:30, for two hours.

Is that agreeable?

Respectfully,

Philip

**PH ILIP CRUMP, Mediator & Facilitator**

1301 Luisa Street Santa Fe, New Mexico 87505

[www.pcmediate.com](http://www.pcmediate.com) Txt/VM: (505) 989-8558

*When I walked out of the gate, I knew that if I continued to hate these people, I would still be in prison. --Nelson Mandela*

On 2/28/2024 2:04 PM, Jackie Fishman wrote:

Pat –

I agree that the meeting shouldn't be during the day as that would prevent working people from participating. The meeting would be via Zoom and in the evening.

I spoke with Brooke this morning and proposed this coming Monday evening for the facilitated meeting. She was agreeable to that date and so I have notified our team. I'm hoping that is agreeable to you as well.

Our intent is to be back in front of the EPC for the March 21<sup>st</sup> hearing. We are gearing up this afternoon to start sending out notifications today. The representatives from the City recognized associations, as well as representatives from the County neighborhood associations, will be receiving an official email notification today from my office. We are also sending out certified mail notices to all property owners within the 100-foot buffer; that list has been vetted and confirmed with the Planning Department's GIS Manager. We are also sending first class mail to the other property owners that were on your map, everyone who attended any of the seven meetings that provided a mailing address, and every address along the east side of Edith. Parks and Rec will be going door to door with copies of the notice as well.

This means some people will likely get 2 or 3 notices in our effort.

I suspect the main agenda item is going to be sound. Let me know if there are specific other items that you would like our team to address.

Please feel free to give me a call to discuss.

**Jacqueline Fishman, AICP**

Principal

Consensus Planning, Inc.

302 Eighth Street NW

Albuquerque, NM 87102

P: 505.764.9801

---

**From:** Pat Hauser <[hdhauser@comcast.net](mailto:hdhauser@comcast.net)>

**Sent:** Wednesday, February 28, 2024 11:50 AM

**To:** Jackie Fishman <[fishman@consensusplanning.com](mailto:fishman@consensusplanning.com)>

**Cc:** Maggie Rose <[gypsy.rose46@gmail.com](mailto:gypsy.rose46@gmail.com)>; Michael Haederle <[haederle@yahoo.com](mailto:haederle@yahoo.com)>; Steve Wentworth <[Anvanews@aol.com](mailto:Anvanews@aol.com)>; Peggy Norton <[peggynorton@yahoo.com](mailto:peggynorton@yahoo.com)>; Evelyn Harris <[grumpyeh46@comcast.net](mailto:grumpyeh46@comcast.net)>; Brooke Jordy <[brookemjordy@gmail.com](mailto:brookemjordy@gmail.com)>; [boyznbari@msn.com](mailto:boyznbari@msn.com); Sandy Zuschlag <[szuschlag58@gmail.com](mailto:szuschlag58@gmail.com)>; Steve Taylor <[staylor@taylortowers.com](mailto:staylor@taylortowers.com)>; 'Steve Horchheimer' <[stemax1@aol.com](mailto:stemax1@aol.com)>; 'Edie Myers' <[emyers\\_11@yahoo.com](mailto:emyers_11@yahoo.com)>; t-marie-v@hotmail.com; Christine Benavidez <[christinebnvdz@aol.com](mailto:christinebnvdz@aol.com)>; 'Lorraine Montoya' <[salamedamontoya@gmail.com](mailto:salamedamontoya@gmail.com)>

**Subject:** RE: Balloon Fiesta Park and NM United

Good morning Ms. Fishman: Thanks for the message regarding the proposed meeting. Your telephone number was blocked on my cellphone as a potential Spam number. Not sure why maybe since you are not in my contact list.

Based on my limited knowledge regarding the meeting it would seem as if it is being planned as a Zoom or something of that nature.

My experience has been that if such a meeting is conducted during the day it seriously hampers many individuals from attending due to their business or work schedules.

I would like to contact several of the other Associations and get their input regarding a possible best time to proceed with such a meeting.

It would also be helpful to know the agenda items and what is planned for possible discussion items that will impact we the property owners.

I have taken the liberty to copy several individuals in on our communication regarding a proposed meeting.

Thanks in advance for working with us on this subject.

Regards: Pat Hauser

---

**From:** Jackie Fishman <[fishman@consensusplanning.com](mailto:fishman@consensusplanning.com)>

**Sent:** Wednesday, February 28, 2024 8:51 AM

**To:** [hdhauser@comcast.net](mailto:hdhauser@comcast.net)

**Cc:** [gypsy.rose46@gmail.com](mailto:gypsy.rose46@gmail.com); [phcrumpsf@gmail.com](mailto:phcrumpsf@gmail.com)

**Subject:** Balloon Fiesta Park and NM United

**Importance:** High

Hi Pat –

I left you a voicemail yesterday in regard to the EPC remand. We would like to schedule a meeting to discuss the project and I've copied the meeting facilitator. We are working on notification and have greatly expanded the list of who we will be sending notification to. Given the number of associations and individuals involved, I would like to work with you to pick a meeting date next week and then my office will add the date to the notification. Could you or Maggie please either email me back or call me to discuss your availability next week?

Thanks, and hope to hear from you soon.

**Jacqueline Fishman, AICP**

Principal

Consensus Planning, Inc.

302 Eighth Street NW

Albuquerque, NM 87102

P: 505.764.9801

## Bolivar, Silvia A.

---

**From:** Peggy Norton <peggynorton@yahoo.com>  
**Sent:** Thursday, February 29, 2024 1:18 PM  
**To:** Pat Hauser; Hummell, Tyson; Philip Crump; Flores, Suzanna A.; Bolivar, Silvia A.; Jackie Fishman; Aranda, James M.  
**Cc:** Maggie Rose; Michael Haederle; Steve Wentworth; Evelyn Harris; Brooke Jordy; boyznbari@msn.com; Sandy Zuschlag; Steve Taylor; 'Steve Horchheimer'; 'Edie Myers'; t-marie-v@hotmail.com; Christine Benavidez; 'Lorraine Montoya'  
**Subject:** Re: Balloon Fiesta Park and NM United

[EXTERNAL] Forward to [phishing@cabq.gov](mailto:phishing@cabq.gov) and delete if an email causes any concern.

Thanks James. I have a call in to ONC and I see Suzanna is on this email. The NARO is clear in defining Coalition membership: recognized neighborhood associations, neighborhood associations, homeowner associations, etc. (Page 8). Note that recognized NA's and NA's are two separate entities. Recognized neighborhood coalitions shall receive notices per the boundaries of member associations or groups only, and not for any individual members. (Page 9). Nothing requires the member associations or groups to be recognized, and obviously groups do not have that pathway. North Edith Corridor is a member of the Coalition and we should be included in notification.

Peggy Norton, President  
North Valley Coalition

On Thursday, February 29, 2024 at 11:57:15 AM MST, Aranda, James M. <jmaranda@cabq.gov> wrote:

Peggy,

Much thanks for reaching out regarding this matter. After previously discussing the matter with Legal, my understanding of the notice requirements is that neighborhood coalitions are only notified if there is a recognized neighborhood association within the coalition boundaries.

As with all EPC cases, the Office of Neighborhood Coordination determines which associations and coalitions are required to be notified. According to the public record associated with the request, the North Valley Coalition was not included on the original notification list, nor was NVC included on the most current notification list. My understanding as to why NVC was not notified is because there were no recognized neighborhood associations within the notification area that are part of NVC.

Please be aware that while the ZEO is responsible for interpreting the provisions of the IDO, I do not have the authority to establish notification boundaries or requirements, nor do I have the authority to interpret NARO's provisions. This being the case, I recommend discussing NARO's notification requirements with ONC staff and leadership. I apologize for any confusion or inconvenience.



Respectfully,

JMA

**JAMES M. ARANDA, MCRP**

deputy director + zeo

505-924-3361

[jmaranda@cabq.gov](mailto:jmaranda@cabq.gov)

[cabq.gov/planning](https://cabq.gov/planning)

---

**From:** Peggy Norton <peggynorton@yahoo.com>

**Sent:** Thursday, February 29, 2024 11:08 AM

**To:** Pat Hauser <hdhauser@comcast.net>; Hummell, Tyson <thummell@cabq.gov>; Philip Crump <phcrumpsf@gmail.com>; Flores, Suzanna A. <SuzannaFlores@cabq.gov>; Aranda, James M. <jmaranda@cabq.gov>; Bolivar, Silvia A. <sabolivar@cabq.gov>; Jackie Fishman <fishman@consensusplanning.com>

**Cc:** Maggie Rose <gypsy.rose46@gmail.com>; Michael Haederle <haederle@yahoo.com>; Steve Wentworth <anvanews@aol.com>; Evelyn Harris <grumpyeh46@comcast.net>; Brooke Jordy <brookemjordy@gmail.com>; boyznbari@msn.com; Sandy Zuschlag <szuschlag58@gmail.com>; Steve Taylor <staylor@taylortowers.com>; 'Steve Horchheimer' <stemax1@aol.com>; 'Edie Myers' <emyers\_11@yahoo.com>; t-marie-v@hotmail.com; Christine Benavidez <christinebnvdz@aol.com>; 'Lorraine Montoya' <alamedamontoya@gmail.com>

**Subject:** Re: Balloon Fiesta Park and NM United

**[EXTERNAL]** Forward to [phishing@cabq.gov](mailto:phishing@cabq.gov) and delete if an email causes any concern.

I looked further into this and I will be communicating with Suzanna and James. My interpretation of NARO requires us to be notified.

Peggy Norton, President

North Valley Coalition

On Wednesday, February 28, 2024 at 07:12:33 PM MST, Jackie Fishman <[fishman@consensusplanning.com](mailto:fishman@consensusplanning.com)> wrote:

Thanks for getting back to us.

**Jacqueline Fishman, AICP**

Principal  
Consensus Planning, Inc.  
302 Eighth Street NW  
Albuquerque, NM 87102  
P: 505.764.9801

---

**From:** Peggy Norton <[peggynorton@yahoo.com](mailto:peggynorton@yahoo.com)>

**Sent:** Wednesday, February 28, 2024 6:55 PM

**To:** Pat Hauser <[hdhauser@comcast.net](mailto:hdhauser@comcast.net)>; [thummell@cabq.gov](mailto:thummell@cabq.gov); Philip Crump <[phcrumpsf@gmail.com](mailto:phcrumpsf@gmail.com)>; [suzannaflores@cabq.gov](mailto:suzannaflores@cabq.gov); Aranda, James M. <[jmaranda@cabq.gov](mailto:jmaranda@cabq.gov)>; Bolivar, Silvia A. <[sabolivar@cabq.gov](mailto:sabolivar@cabq.gov)>; Jackie Fishman <[fishman@consensusplanning.com](mailto:fishman@consensusplanning.com)>

**Cc:** Maggie Rose <[gypsy.rose46@gmail.com](mailto:gypsy.rose46@gmail.com)>; Michael Haederle <[haederle@yahoo.com](mailto:haederle@yahoo.com)>; Steve Wentworth <[anvanews@aol.com](mailto:anvanews@aol.com)>; Evelyn Harris <[grumpyeh46@comcast.net](mailto:grumpyeh46@comcast.net)>; Brooke Jordy <[brookemjordy@gmail.com](mailto:brookemjordy@gmail.com)>; [boyznbari@msn.com](mailto:boyznbari@msn.com); Sandy Zuschlag <[szuschlag58@gmail.com](mailto:szuschlag58@gmail.com)>; Steve Taylor <[staylor@taylortowers.com](mailto:staylor@taylortowers.com)>; 'Steve Horchheimer' <[stemax1@aol.com](mailto:stemax1@aol.com)>; 'Edie Myers' <[emyers\\_11@yahoo.com](mailto:emyers_11@yahoo.com)>; [t-marie-v@hotmail.com](mailto:t-marie-v@hotmail.com); Christine Benavidez <[christinebnvdz@aol.com](mailto:christinebnvdz@aol.com)>; 'Lorraine Montoya' <[alamedamontoya@gmail.com](mailto:alamedamontoya@gmail.com)>

**Subject:** Re: Balloon Fiesta Park and NM United

I checked a couple boundaries and they are correct to omit us.

Peggy Norton, President  
North Valley Coalition

On Wednesday, February 28, 2024 at 05:42:20 PM MST, Jackie Fishman <[fishman@consensusplanning.com](mailto:fishman@consensusplanning.com)> wrote:

Ms. Norton –

Thanks for your email. The Office of Neighborhood Coordination determines which associations and coalitions are required to be notified – the NVC was not included on the original list or the most current list. I've copied Susie Flores (ONC) and James Aranda (ZEO) on this email and you are welcome to discuss your concern about notification to the NVC with both of them.

**Jacqueline Fishman, AICP**

Principal  
Consensus Planning, Inc.  
302 Eighth Street NW  
Albuquerque, NM 87102  
P: 505.764.9801

**From:** Peggy Norton <[peggynorton@yahoo.com](mailto:peggynorton@yahoo.com)>

**Sent:** Wednesday, February 28, 2024 5:29 PM

**To:** Jackie Fishman <[fishman@consensusplanning.com](mailto:fishman@consensusplanning.com)>; Pat Hauser <[hdhauser@comcast.net](mailto:hdhauser@comcast.net)>; [thummell@cabq.gov](mailto:thummell@cabq.gov); Philip Crump <[phcrumpsf@gmail.com](mailto:phcrumpsf@gmail.com)>

**Cc:** Maggie Rose <[gypsy.rose46@gmail.com](mailto:gypsy.rose46@gmail.com)>; Michael Haederle <[haederle@yahoo.com](mailto:haederle@yahoo.com)>; Steve Wentworth <[anvanews@aol.com](mailto:anvanews@aol.com)>; Evelyn Harris <[grumpyeh46@comcast.net](mailto:grumpyeh46@comcast.net)>; Brooke Jordy <[brookemjordy@gmail.com](mailto:brookemjordy@gmail.com)>; [boyznbari@msn.com](mailto:boyznbari@msn.com); Sandy Zuschlag <[szuschlag58@gmail.com](mailto:szuschlag58@gmail.com)>; Steve Taylor <[staylor@taylortowers.com](mailto:staylor@taylortowers.com)>; 'Steve Horchheimer' <[stemax1@aol.com](mailto:stemax1@aol.com)>; 'Edie Myers' <[emyers\\_11@yahoo.com](mailto:emyers_11@yahoo.com)>; [t-marie-v@hotmail.com](mailto:t-marie-v@hotmail.com); Christine Benavidez <[christinebnvdz@aol.com](mailto:christinebnvdz@aol.com)>; 'Lorraine Montoya' <[alamedamontoya@gmail.com](mailto:alamedamontoya@gmail.com)>

**Subject:** Re: Balloon Fiesta Park and NM United

As a coalition representative who never received notice on the first round, I would like to comment on this. I have not read the remand order from the Land Use Hearing Officer, but evidently, the legally required notification was lacking. I am hoping we will be included in this round, but I am not sure of that. Giving less than 5 days notice for a public facilitated meeting about the soccer stadium hardly seems to comply with appropriate notice. Generally, notification for an EPC meeting allows interested parties 15 days to request a meeting. Perhaps this remand order negated that requirement. I am a little behind in this case and will look for the remand order, but I wanted to get these comments in. Additionally, Monday is a City Council meeting.

Peggy Norton, President  
North Valley Coalition

On Wednesday, February 28, 2024 at 02:30:59 PM MST, Philip Crump <[phcrumpsf@gmail.com](mailto:phcrumpsf@gmail.com)> wrote:

Thank you, Jackie and Pat.

I can send a Google Meet invitation for Monday the 4th, starting at 5:30, for two hours.

Is that agreeable?

Respectfully,

Philip



**PHILIP CRUMP, Mediator & Facilitator**

1301 Luisa Street Santa Fe, New Mexico 87505

[www.pcmediate.com](http://www.pcmediate.com) Txt/VM: (505) 989-8558

*When I walked out of the gate, I knew that if I continued to hate these people, I would still be in prison. --Nelson Mandela*

On 2/28/2024 2:04 PM, Jackie Fishman wrote:

Pat –

I agree that the meeting shouldn't be during the day as that would prevent working people from participating. The meeting would be via Zoom and in the evening.

I spoke with Brooke this morning and proposed this coming Monday evening for the facilitated meeting. She was agreeable to that date and so I have notified our team. I'm hoping that is agreeable to you as well.

Our intent is to be back in front of the EPC for the March 21<sup>st</sup> hearing. We are gearing up this afternoon to start sending out notifications today. The representatives from the City recognized associations, as well as representatives from the County neighborhood associations, will be receiving an official email notification today from my office. We are also sending out certified mail notices to all property owners within the 100-foot buffer; that list has been vetted and confirmed with the Planning Department's GIS Manager. We are also sending first class mail to the other property owners that were on your map, everyone who attended any of the seven meetings that provided a mailing address, and every address along the east side of Edith. Parks and Rec will be going door to door with copies of the notice as well. This means some people will likely get 2 or 3 notices in our effort.

I suspect the main agenda item is going to be sound. Let me know if there are specific other items that you would like our team to address.

Please feel free to give me a call to discuss.

**Jacqueline Fishman, AICP**

Principal  
Consensus Planning, Inc.  
302 Eighth Street NW  
Albuquerque, NM 87102  
P: 505.764.9801

---

**From:** Pat Hauser <[hdhauser@comcast.net](mailto:hdhauser@comcast.net)>

**Sent:** Wednesday, February 28, 2024 11:50 AM

**To:** Jackie Fishman <[fishman@consensusplanning.com](mailto:fishman@consensusplanning.com)>

**Cc:** Maggie Rose <[gypsy.rose46@gmail.com](mailto:gypsy.rose46@gmail.com)>; Michael Haederle <[haederle@yahoo.com](mailto:haederle@yahoo.com)>; Steve Wentworth <[Anvanews@aol.com](mailto:Anvanews@aol.com)>; Peggy Norton <[peggynorton@yahoo.com](mailto:peggynorton@yahoo.com)>; Evelyn Harris <[grumpyeh46@comcast.net](mailto:grumpyeh46@comcast.net)>; Brooke Jordy <[brookemjordy@gmail.com](mailto:brookemjordy@gmail.com)>; boyznbari@msn.com; Sandy Zuschlag <[szuschlag58@gmail.com](mailto:szuschlag58@gmail.com)>; Steve Taylor <[staylor@taylortowers.com](mailto:staylor@taylortowers.com)>; 'Steve Horchheimer' <[stemax1@aol.com](mailto:stemax1@aol.com)>; 'Edie Myers' <[emyers\\_11@yahoo.com](mailto:emyers_11@yahoo.com)>; t-marie-v@hotmail.com; Christine Benavidez <[christinebnvdz@aol.com](mailto:christinebnvdz@aol.com)>; 'Lorraine Montoya' <[alamedamontoya@gmail.com](mailto:alamedamontoya@gmail.com)>

**Subject:** RE: Balloon Fiesta Park and NM United

Good morning Ms. Fishman: Thanks for the message regarding the proposed meeting. Your telephone number was blocked on my cellphone as a potential Spam number.

Not sure why maybe since you are not in my contact list.

Based on my limited knowledge regarding the meeting it would seem as if it is being planned as a Zoom or something of that nature.

My experience has been that if such a meeting is conducted during the day it seriously hampers many individuals from attending due to their business or work schedules.

I would like to contact several of the other Associations and get their input regarding a possible best time to proceed with such a meeting.

It would also be helpful to know the agenda items and what is planned for possible discussion items that will impact we the property owners.

I have taken the liberty to copy several individuals in on our communication regarding a proposed meeting.

Thanks in advance for working with us on this subject.

Regards: Pat Hauser

---

**From:** Jackie Fishman <[fishman@consensusplanning.com](mailto:fishman@consensusplanning.com)>

**Sent:** Wednesday, February 28, 2024 8:51 AM

**To:** [hdhauser@comcast.net](mailto:hdhauser@comcast.net)

**Cc:** [gypsy.rose46@gmail.com](mailto:gypsy.rose46@gmail.com); [phcrumpsf@gmail.com](mailto:phcrumpsf@gmail.com)

**Subject:** Balloon Fiesta Park and NM United

**Importance:** High

Hi Pat –

I left you a voicemail yesterday in regard to the EPC remand. We would like to schedule a meeting to discuss the project and I've copied the meeting facilitator. We are working on notification and have greatly expanded the list of who we will be sending notification to. Given the number of associations and individuals involved, I would like to work with you to pick a meeting date next week and then my office will add the date to the notification. Could you or Maggie please either email me back or call me to discuss your availability next week?

Thanks, and hope to hear from you soon.

**Jacqueline Fishman, AICP**

Principal  
Consensus Planning, Inc.

302 Eighth Street NW  
Albuquerque, NM 87102  
P: 505.764.9801

**From:** [Regina Jolley \(via Google Docs\)](#)  
**To:** [Bolivar, Silvia A.](#)  
**Subject:** March 6, 2024  
**Date:** Friday, March 8, 2024 4:00:42 PM

---

[EXTERNAL] Forward to [phishing@cabq.gov](mailto:phishing@cabq.gov) and delete if an email causes any concern.

## Regina Jolley attached a document

 Regina Jolley ([gjolley007@gmail.com](mailto:gjolley007@gmail.com)) has attached the following document:

Please read

 March 6, 2024

### *Snapshot of the item below:*

March 6, 2024

Environmental Planning Committee  
City of Albuquerque  
% Silvia Bolivar  
[sabolivar@cabq.gov](mailto:sabolivar@cabq.gov)  
[PlanningEPC@cabq.gov](mailto:PlanningEPC@cabq.gov)

VIA ELECTRONIC MAIL

Dear Ms. Bolivar,

As a taxpayer and homeowner within the city limits of Albuquerque, I am concerned about the building of the United Sports area at the Balloon Fiesta location in the northwestern quadrant of Albuquerque. I am in opposition to the construction for a variety of reasons but my main concerns are the following:

- The amount of traffic that will be present in our small community, if the stadium is to hold 11,000 people and 2 people per car, that is 5500 cars in a small area, that would be a large amount of emissions being put into the air for our housing community, if these games and the other



proposed events happen during low cloud coverage causing a downward draft of carbon monoxide or brown cloud effect.

- Depending on the time of the games the commute home would increase. An example when there is a wreck on Paseo going west the traffic diverts to Alameda it increases the commute home to upwards of 45 minutes. Now, if we are to be dealing with individuals attempting to access the stadium on a regular basis that increases our commute home by at least half an hour to 45 minutes every time there is a game, which normally is all but 7 minutes.
- Excessive noise levels that would affect our well being (i.e. sleeping habits and patterns) and those of the wellbeing of our domestic animals and wildlife fowls.
- Excessive lighting that would affect our well being (i.e. sleeping habits) and that of our domestic animals and wildlife fowls.
- The Wildflower Park will be affected by individuals that would want to stop and have a small picnic/drinks before and/or after the game, leaving trash and debris at the park. At present there are no facilities at the park, so where would people be able to urinate and/or defecate should the need arise.
- The possibility of people stopping at local breweries/eateries that presently do not have enough parking to accommodate their guests would overflow to the Wildflower community causing disruptions to our way of life and the ability to enter and exit our home.

These concerns do not even include the monetary price that we will endure if the stadium proceeds. I do not know if you are the person that would address the monetary issues. Does the property value decrease? Property taxes increase?, the wear and tear of the roads on San Mateo? the longevity it would take to enter and exit our home during game nights?. Trash that is blown into our neighborhood from the overflow from the park? Increase of crime (more people become aware of our small community/break-ins.

I would appreciate you giving a thoughtful review of the above concerns and vetoing the proposed building of the stadium.

Thank you for your time and attention  
Regina J. Jolley

Google LLC, 1600 Amphitheatre Parkway, Mountain View, CA 94043, USA

You have received this email because [gjolley007@gmail.com](mailto:gjolley007@gmail.com) shared a document with you from Google Docs.



## Bolivar, Silvia A.

---

**From:** Baca, Vanessa  
**Sent:** Thursday, February 29, 2024 4:54 PM  
**To:** 'peggynorton@yahoo.com'  
**Cc:** 'Pat Hauser'; Hummell, Tyson; 'Philip Crump'; Flores, Suzanna A.; Bolivar, Silvia A.; 'Jackie Fishman'; Aranda, James M.; 'Cc: Maggie Rose'; 'Michael Haederle'; 'Steve Wentworth'; 'Evelyn Harris'; 'Brooke Jordy'; 'boyznbari@msn.com'; 'Sandy Zuschlag'; 'Steve Taylor'; 'Steve Horchheimer'; 'Edie Myers'; 't-marie-v@hotmail.com'; 'Christine Benavidez'; 'Lorraine Montoya'  
**Subject:** FW: Balloon Fiesta Park and NM United  
**Attachments:** North Edith Corridor Map\_June 2023.pdf

Hi Peggy.

Thank you for your earlier e-mail inquiries regarding developer notice for the property at 5601 Balloon Fiesta Parkway.

The Neighborhood Association Recognition Ordinance (NARO) stipulates in Section §14-8-2-4 (B) (5) that for the purposes of notice, recognized neighborhood coalitions shall receive notice per the boundaries of member associations or groups only, and not for any individual members. In this particular case, the property site in question is within the boundaries of the Wildflower Neighborhood Association, which is itself a member of the District 4 Coalition. As such, both the Wildflower NA and the D4 Coalition received developer notice, as required by the Integrated Development Ordinance (IDO).

To address your specific question about the North Edith Commercial Corridor Association (NEC), the reason that the North Valley Coalition was not notified on behalf of NEC is because the property site in question is not adjacent to the eastern boundary of the NEC. The IDO defines adjacency as: those properties that are abutting or separated only by a street, alley, trail, or utility easement, whether public or private.

I have attached a map of the NEC boundaries that are on file with the Office of Neighborhood Coordination (ONC). As you can see demonstrated by the red outline, the eastern boundary of the NEC is Edith Boulevard. The properties which are adjacent to the subject site are not within the boundaries of the NEC, nor is the subject site within the boundaries of the NEC.

Please let me know if you need additional information.



**Vanessa Baca**  
Manager

Office of Neighborhood Coordination (ONC) | City Council Department | City of Albuquerque  
(505) 768-3331 Office

E-mail: [vanessabaca@cabq.gov](mailto:vanessabaca@cabq.gov)

Website: [www.cabq.gov/neighborhoods](http://www.cabq.gov/neighborhoods)



**From:** Peggy Norton <peggynorton@yahoo.com>

**Sent:** Thursday, February 29, 2024 1:18 PM

**To:** Pat Hauser <hdhauser@comcast.net>; Hummell, Tyson <thummell@cabq.gov>; Philip Crump <phcrumpsf@gmail.com>; Flores, Suzanna A. <Suzannaflor@cabq.gov>; Bolivar, Silvia A. <sabolivar@cabq.gov>; Jackie Fishman <fishman@consensusplanning.com>; Aranda, James M. <jmaranda@cabq.gov>

**Cc:** Maggie Rose <gypsy.rose46@gmail.com>; Michael Haederle <haederle@yahoo.com>; Steve Wentworth <anvanews@aol.com>; Evelyn Harris <grumpyeh46@comcast.net>; Brooke Jordy <brookemjordy@gmail.com>; boyznbari@msn.com; Sandy Zuschlag <szuschlag58@gmail.com>; Steve Taylor <staylor@taylortowers.com>; 'Steve Horchheimer' <stemax1@aol.com>; 'Edie Myers' <emyers\_11@yahoo.com>; t-marie-v@hotmail.com; Christine Benavidez <christinebnvdz@aol.com>; 'Lorraine Montoya' <alamedamontoya@gmail.com>

**Subject:** Re: Balloon Fiesta Park and NM United

[EXTERNAL] Forward to [phishing@cabq.gov](mailto:phishing@cabq.gov) and delete if an email causes any concern.

Thanks James. I have a call in to ONC and I see Suzanna is on this email. The NARO is clear in defining Coalition membership: recognized neighborhood associations, neighborhood associations, homeowner associations, etc. (Page 8). Note that recognized NA's and NA's are two separate entities. Recognized neighborhood coalitions shall receive notices per the boundaries of member associations or groups only, and not for any individual members. (Page 9). Nothing requires the member associations or groups to be recognized, and obviously groups do not have that pathway. North Edith Corridor is a member of the Coalition and we should be included in notification.

Peggy Norton, President  
North Valley Coalition

On Thursday, February 29, 2024 at 11:57:15 AM MST, Aranda, James M. <[jmaranda@cabq.gov](mailto:jmaranda@cabq.gov)> wrote:

Peggy,

Much thanks for reaching out regarding this matter. After previously discussing the matter with Legal, my understanding of the notice requirements is that neighborhood coalitions are only notified if there is a recognized neighborhood association within the coalition boundaries.

As with all EPC cases, the Office of Neighborhood Coordination determines which associations and coalitions are required to be notified. According to the public record associated with the request, the North Valley Coalition was not included on the original notification list, nor was NVC included on the most current notification list. My understanding as to why NVC was not notified is because there were no recognized neighborhood associations within the notification area that are part of NVC.

Please be aware that while the ZEO is responsible for interpreting the provisions of the IDO, I do not have the authority to establish notification boundaries or requirements, nor do I have the authority to interpret NARO's provisions. This being the case, I recommend discussing NARO's notification requirements with ONC staff and leadership. I apologize for any confusion or inconvenience.

Respectfully,

JMA

**JAMES M. ARANDA, MCRP**

deputy director + zeo

505-924-3361

[jmaranda@cabq.gov](mailto:jmaranda@cabq.gov)

[cabq.gov/planning](http://cabq.gov/planning)

---

**From:** Peggy Norton <[peggynorton@yahoo.com](mailto:peggynorton@yahoo.com)>

**Sent:** Thursday, February 29, 2024 11:08 AM

**To:** Pat Hauser <[hdhauser@comcast.net](mailto:hdhauser@comcast.net)>; Hummell, Tyson <[thummell@cabq.gov](mailto:thummell@cabq.gov)>; Philip Crump <[phcrumpsf@gmail.com](mailto:phcrumpsf@gmail.com)>; Flores, Suzanna A. <[SuzannaFlores@cabq.gov](mailto:SuzannaFlores@cabq.gov)>; Aranda, James M. <[jmaranda@cabq.gov](mailto:jmaranda@cabq.gov)>; Bolivar, Silvia A. <[sabolivar@cabq.gov](mailto:sabolivar@cabq.gov)>; Jackie Fishman <[fishman@consensusplanning.com](mailto:fishman@consensusplanning.com)>

**Cc:** Maggie Rose <[gypsy.rose46@gmail.com](mailto:gypsy.rose46@gmail.com)>; Michael Haederle <[haederle@yahoo.com](mailto:haederle@yahoo.com)>; Steve Wentworth <[anvanews@aol.com](mailto:anvanews@aol.com)>; Evelyn Harris <[grumpyeh46@comcast.net](mailto:grumpyeh46@comcast.net)>; Brooke Jordy <[brookemjordy@gmail.com](mailto:brookemjordy@gmail.com)>; boyznbari@msn.com; Sandy Zuschlag <[szuschlag58@gmail.com](mailto:szuschlag58@gmail.com)>; Steve Taylor <[staylor@taylortowers.com](mailto:staylor@taylortowers.com)>; 'Steve Horchheimer' <[stemax1@aol.com](mailto:stemax1@aol.com)>; 'Edie Myers' <[emyers\\_11@yahoo.com](mailto:emyers_11@yahoo.com)>; t-marie-v@hotmail.com; Christine Benavidez <[christinebnvdz@aol.com](mailto:christinebnvdz@aol.com)>; 'Lorraine Montoya' <[alamedamontoya@gmail.com](mailto:alamedamontoya@gmail.com)>

**Subject:** Re: Balloon Fiesta Park and NM United

**[EXTERNAL]** Forward to [phishing@cabq.gov](mailto:phishing@cabq.gov) and delete if an email causes any concern.

I looked further into this and I will be communicating with Suzanna and James. My interpretation of NARO requires us to be notified.

Peggy Norton, President

North Valley Coalition

On Wednesday, February 28, 2024 at 07:12:33 PM MST, Jackie Fishman <[fishman@consensusplanning.com](mailto:fishman@consensusplanning.com)> wrote:

Thanks for getting back to us.

**Jacqueline Fishman, AICP**

Principal  
Consensus Planning, Inc.  
302 Eighth Street NW  
Albuquerque, NM 87102  
P: 505.764.9801

---

**From:** Peggy Norton <[peggynorton@yahoo.com](mailto:peggynorton@yahoo.com)>  
**Sent:** Wednesday, February 28, 2024 6:55 PM  
**To:** Pat Hauser <[hdhauser@comcast.net](mailto:hdhauser@comcast.net)>; [thummell@cabq.gov](mailto:thummell@cabq.gov); Philip Crump <[phcrumpsf@gmail.com](mailto:phcrumpsf@gmail.com)>; [suzannaflores@cabq.gov](mailto:suzannaflores@cabq.gov); Aranda, James M. <[jmaranda@cabq.gov](mailto:jmaranda@cabq.gov)>; Bolivar, Silvia A. <[sabolivar@cabq.gov](mailto:sabolivar@cabq.gov)>; Jackie Fishman <[fishman@consensusplanning.com](mailto:fishman@consensusplanning.com)>  
**Cc:** Maggie Rose <[gypsy.rose46@gmail.com](mailto:gypsy.rose46@gmail.com)>; Michael Haederle <[haederle@yahoo.com](mailto:haederle@yahoo.com)>; Steve Wentworth <[anvanews@aol.com](mailto:anvanews@aol.com)>; Evelyn Harris <[grumpyeh46@comcast.net](mailto:grumpyeh46@comcast.net)>; Brooke Jordy <[brookemjordy@gmail.com](mailto:brookemjordy@gmail.com)>; [boyznbari@msn.com](mailto:boyznbari@msn.com); Sandy Zuschlag <[szuschlag58@gmail.com](mailto:szuschlag58@gmail.com)>; Steve Taylor <[staylor@taylortowers.com](mailto:staylor@taylortowers.com)>; 'Steve Horchheimer' <[stemax1@aol.com](mailto:stemax1@aol.com)>; 'Edie Myers' <[emyers\\_11@yahoo.com](mailto:emyers_11@yahoo.com)>; [t-marie-v@hotmail.com](mailto:t-marie-v@hotmail.com); Christine Benavidez <[christinebnvdz@aol.com](mailto:christinebnvdz@aol.com)>; 'Lorraine Montoya' <[alamedamontoya@gmail.com](mailto:alamedamontoya@gmail.com)>  
**Subject:** Re: Balloon Fiesta Park and NM United

I checked a couple boundaries and they are correct to omit us.

Peggy Norton, President  
North Valley Coalition

On Wednesday, February 28, 2024 at 05:42:20 PM MST, Jackie Fishman <[fishman@consensusplanning.com](mailto:fishman@consensusplanning.com)> wrote:

Ms. Norton –

Thanks for your email. The Office of Neighborhood Coordination determines which associations and coalitions are required to be notified – the NVC was not included on the original list or the most current list. I've copied Susie Flores (ONC) and James Aranda (ZEO) on this email and you are welcome to discuss your concern about notification to the NVC with both of them.

**Jacqueline Fishman, AICP**

Principal  
Consensus Planning, Inc.  
302 Eighth Street NW  
Albuquerque, NM 87102  
P: 505.764.9801

**From:** Peggy Norton <[peggynorton@yahoo.com](mailto:peggynorton@yahoo.com)>

**Sent:** Wednesday, February 28, 2024 5:29 PM

**To:** Jackie Fishman <[fishman@consensusplanning.com](mailto:fishman@consensusplanning.com)>; Pat Hauser <[hdhauser@comcast.net](mailto:hdhauser@comcast.net)>; [thummell@cabq.gov](mailto:thummell@cabq.gov); Philip Crump <[phcrumpsf@gmail.com](mailto:phcrumpsf@gmail.com)>

**Cc:** Maggie Rose <[gypsy.rose46@gmail.com](mailto:gypsy.rose46@gmail.com)>; Michael Haederle <[haederle@yahoo.com](mailto:haederle@yahoo.com)>; Steve Wentworth <[anvanews@aol.com](mailto:anvanews@aol.com)>; Evelyn Harris <[grumpyeh46@comcast.net](mailto:grumpyeh46@comcast.net)>; Brooke Jordy <[brookemjordy@gmail.com](mailto:brookemjordy@gmail.com)>; [boyznbari@msn.com](mailto:boyznbari@msn.com); Sandy Zuschlag <[szuschlag58@gmail.com](mailto:szuschlag58@gmail.com)>; Steve Taylor <[staylor@taylortowers.com](mailto:staylor@taylortowers.com)>; 'Steve Horchheimer' <[stemax1@aol.com](mailto:stemax1@aol.com)>; 'Edie Myers' <[emyers\\_11@yahoo.com](mailto:emyers_11@yahoo.com)>; [t-marie-v@hotmail.com](mailto:t-marie-v@hotmail.com); Christine Benavidez <[christinebnvdz@aol.com](mailto:christinebnvdz@aol.com)>; 'Lorraine Montoya' <[alamedamontoya@gmail.com](mailto:alamedamontoya@gmail.com)>

**Subject:** Re: Balloon Fiesta Park and NM United

As a coalition representative who never received notice on the first round, I would like to comment on this. I have not read the remand order from the Land Use Hearing Officer, but evidently, the legally required notification was lacking. I am hoping we will be included in this round, but I am not sure of that. Giving less than 5 days notice for a public facilitated meeting about the soccer stadium hardly seems to comply with appropriate notice. Generally, notification for an EPC meeting allows interested parties 15 days to request a meeting. Perhaps this remand order negated that requirement. I am a little behind in this case and will look for the remand order, but I wanted to get these comments in. Additionally, Monday is a City Council meeting.

Peggy Norton, President  
North Valley Coalition

On Wednesday, February 28, 2024 at 02:30:59 PM MST, Philip Crump <[phcrumpsf@gmail.com](mailto:phcrumpsf@gmail.com)> wrote:

Thank you, Jackie and Pat.

I can send a Google Meet invitation for Monday the 4th, starting at 5:30, for two hours.

Is that agreeable?

Respectfully,

Philip



**PHILIP CRUMP, Mediator & Facilitator**

1301 Luisa Street Santa Fe, New Mexico 87505

[www.pcmediate.com](http://www.pcmediate.com) Txt/VM: (505) 989-8558

*When I walked out of the gate, I knew that if I continued to hate these people, I would still be in prison. --Nelson Mandela*

On 2/28/2024 2:04 PM, Jackie Fishman wrote:

Pat –

I agree that the meeting shouldn't be during the day as that would prevent working people from participating. The meeting would be via Zoom and in the evening.

I spoke with Brooke this morning and proposed this coming Monday evening for the facilitated meeting. She was agreeable to that date and so I have notified our team. I'm hoping that is agreeable to you as well.

Our intent is to be back in front of the EPC for the March 21<sup>st</sup> hearing. We are gearing up this afternoon to start sending out notifications today. The representatives from the City recognized associations, as well as representatives from the County neighborhood associations, will be receiving an official email notification today from my office. We are also sending out certified mail notices to all property owners within the 100-foot buffer; that list has been vetted and confirmed with the Planning Department's GIS Manager. We are also sending first class mail to the other property owners that were on your map, everyone who attended any of the seven meetings that provided a mailing address, and every address along the east side of Edith. Parks and Rec will be going door to door with copies of the notice as well. This means some people will likely get 2 or 3 notices in our effort.

I suspect the main agenda item is going to be sound. Let me know if there are specific other items that you would like our team to address.



Please feel free to give me a call to discuss.

**Jacqueline Fishman, AICP**

Principal  
Consensus Planning, Inc.  
302 Eighth Street NW  
Albuquerque, NM 87102  
P: 505.764.9801

---

**From:** Pat Hauser <[hdhauser@comcast.net](mailto:hdhauser@comcast.net)>

**Sent:** Wednesday, February 28, 2024 11:50 AM

**To:** Jackie Fishman <[fishman@consensusplanning.com](mailto:fishman@consensusplanning.com)>

**Cc:** Maggie Rose <[gypsy.rose46@gmail.com](mailto:gypsy.rose46@gmail.com)>; Michael Haederle <[haederle@yahoo.com](mailto:haederle@yahoo.com)>; Steve Wentworth <[Anvanews@aol.com](mailto:Anvanews@aol.com)>; Peggy Norton <[peggynorton@yahoo.com](mailto:peggynorton@yahoo.com)>; Evelyn Harris <[grumpyeh46@comcast.net](mailto:grumpyeh46@comcast.net)>; Brooke Jordy <[brookemjordy@gmail.com](mailto:brookemjordy@gmail.com)>; [boyznbari@msn.com](mailto:boyznbari@msn.com); Sandy Zuschlag <[szuschlag58@gmail.com](mailto:szuschlag58@gmail.com)>; Steve Taylor <[staylor@taylortowers.com](mailto:staylor@taylortowers.com)>; 'Steve Horchheimer' <[stemax1@aol.com](mailto:stemax1@aol.com)>; 'Edie Myers' <[emyers\\_11@yahoo.com](mailto:emyers_11@yahoo.com)>; [t-marie-v@hotmail.com](mailto:t-marie-v@hotmail.com); Christine Benavidez <[christinebnvdz@aol.com](mailto:christinebnvdz@aol.com)>; 'Lorraine Montoya' <[alamedamontoya@gmail.com](mailto:alamedamontoya@gmail.com)>

**Subject:** RE: Balloon Fiesta Park and NM United

Good morning Ms. Fishman: Thanks for the message regarding the proposed meeting. Your telephone number was blocked on my cellphone as a potential Spam number.

Not sure why maybe since you are not in my contact list.

Based on my limited knowledge regarding the meeting it would seem as if it is being planned as a Zoom or something of that nature.

My experience has been that if such a meeting is conducted during the day it seriously hampers many individuals from attending due to their business or work schedules.

I would like to contact several of the other Associations and get their input regarding a possible best time to proceed with such a meeting.

It would also be helpful to know the agenda items and what is planned for possible discussion items that will impact we the property owners.

I have taken the liberty to copy several individuals in on our communication regarding a proposed meeting.

Thanks in advance for working with us on this subject.

Regards: Pat Hauser

---

**From:** Jackie Fishman <[fishman@consensusplanning.com](mailto:fishman@consensusplanning.com)>

**Sent:** Wednesday, February 28, 2024 8:51 AM

**To:** [hdhauser@comcast.net](mailto:hdhauser@comcast.net)

**Cc:** [gypsy.rose46@gmail.com](mailto:gypsy.rose46@gmail.com); [phcrumpsf@gmail.com](mailto:phcrumpsf@gmail.com)

**Subject:** Balloon Fiesta Park and NM United

**Importance:** High

Hi Pat –

I left you a voicemail yesterday in regard to the EPC remand. We would like to schedule a meeting to discuss the project and I've copied the meeting facilitator. We are working on notification and have greatly expanded the list of who we will be sending notification to. Given the number of associations and individuals involved, I would like to work with you to pick a meeting date next week and then my office will add the date to the notification. Could you or Maggie please either email me back or call me to discuss your availability next week?

Thanks, and hope to hear from you soon.

**Jacqueline Fishman, AICP**

Principal  
Consensus Planning, Inc.

302 Eighth Street NW  
Albuquerque, NM 87102  
P: 505.764.9801

**From:** [Rosalie Johnson](#)  
**To:** [brookemjordy@gmail.com](mailto:brookemjordy@gmail.com); [Bolivar, Silvia A.](#); [Planning EPC](#)  
**Subject:** Re: Time-Sensitive Correspondence from Appellants (Appeal No. AC-23-22)  
**Date:** Sunday, March 10, 2024 9:56:20 PM

---

**[EXTERNAL]** Forward to [phishing@cabq.gov](mailto:phishing@cabq.gov) and delete if an email causes any concern.

Good morning. Our family has lived in the Wildfire Neighborhood since 1985. We love our relatively quiet neighborhood, albeit the Balloon Fiesta, but that only lasts for 9 days!

One can put up with almost anything for 9 days.

The traffic during the Fiesta greatly impacts us, especially during the special events days and on weekends. We receive neighborhood passes; however, police choose to ignore the pass which then takes getting home much, much, longer and a nightmare! Because of limited parking at Fiesta, cars park along many of our streets and use our streets as thoroughfares. In our neighborhood, we can see lights, hear microphones, bands, and any noise.

Another concern is property values. It's a known fact that a soccer field brings down the selling points and value of homes in the area.

Thank you for your time and consideration.

Rosalie Johnson

[Yahoo Mail: Search, Organize, Conquer](#)

On Fri, Mar 8, 2024 at 9:12 AM, Brooke Jordy  
<[brookemjordy@gmail.com](mailto:brookemjordy@gmail.com)> wrote:

Good morning,

Please see the attached letter from neighbors opposing the stadium in Balloon Fiesta Park. We are formally requesting that the EPC hearing be rescheduled from the March 2024 docket to the April 2024 docket to allow for proper preparation and to comport with due process requirements.

Please do not hesitate to reach out if you have any questions.

All the best,

Brooke Jordy  
575-770-4389

**Bolivar, Silvia A.**

---

**From:** Sandy Zuschlag <szuschlag58@gmail.com>  
**Sent:** Friday, March 1, 2024 6:15 AM  
**To:** Jackie Fishman  
**Cc:** Pat Hauser; Hummell, Tyson; phcrumpsf@gmail.com; Bolivar, Silvia A.; Maggie Rose; Michael Haederle; Steve Wentworth; Peggy Norton; Evelyn Harris; Brooke Jordy; boyznbari@msn.com; Steve Taylor; Steve Horchheimer; Edie Myers; t-marie-v@hotmail.com; Christine Benavidez; Lorraine Montoya; Flores, David M.; Simon, David J.  
**Subject:** Balloon Fiesta Park and NM United

[EXTERNAL] Forward to [phishing@cabq.gov](mailto:phishing@cabq.gov) and delete if an email causes any concern.

March 1, 2024

Good morning Jackie, interested neighbors of Balloon Fiesta Park and City staff,

It appears from Jackie's comments that the approach to this remand is viewed as a technical step, not a real effort to listen and work together. I am not sure how the record gets corrected but there were several deficiencies that would have been addressed at the Remand Hearing. I understood that Mr. Chavez was recommending a de novo, or to start over. This current "planning" approach again misses the point that the neighbors living around Balloon Fiesta Park have multiple concerns. This is not "a do over" as currently planned.

It isn't "just about noise" which in itself is a significant issue. How is one hastily scheduled meeting and setting the EPC Hearing date without listening to people demonstrate a willingness to work together?

To now indicate that the lack of notification was a technical problem and that a meeting was not required per the remand is setting the stage for another round of poor attempts to communicate.

Many individuals have provided multiple written comments that have not been addressed by the City, Consensus Planning or United New Mexico. That again shows a true lack of interest to address the concerns about the proposed stadium project. Why hasn't this happen, because it is not required? I would recommend that those comments be reread and addressed in writing to ensure good communication.

“Inexplicably” not notifying the neighbors west of the park is incorrect. In October and November, prior to the EPC hearing on multiple occasions I reached out to Jackie via phone calls and emails about not all of the neighbors within the 100 foot buffer being notified. My comments were not taken seriously; just like comments and questions are not being taken seriously now.

I would recommend the meeting scheduled for Monday be moved to a later date and the format be more inclusive. Telling people you are moving forward with the EPC hearing before meeting and LISTENING to people again demonstrates an unwillingness to work together. At my meeting with City staff, I was told New Mexico United wants to be a good neighbor. How is this being accomplished now? Does the City want to be a good neighbor?

Questions I have about this “process” are:

1. Are the comments made in the original hearing process part of the record of this “do over”? How are inaccuracies in the reporting from the original case addressed?
2. When are the written comments due for the planned EPC Hearing on March 21<sup>st</sup>?
3. What will be the format for the EPC hearing? Allowing two minutes doesn’t allow adequate time for the concerns to be addressed.
4. Are these email communications part of the official record?

Please, take a moment and really listen to what people are saying. I have copied this email to David Flores and David Simon so hopefully a true effort is made to be a “good neighbor”.

Sent from my iPad

On Feb 29, 2024, at 1:50 PM, Jackie Fishman <fishman@consensusplanning.com> wrote:

For clarification, the remand is based on the seven property owner addresses that were inexplicably not included in the original notice of hearing last October. Hearing notification is required 15 days before the hearing- we have done this well in advance of the required timeframe.

This is what the LUHO's decision said:

“Notice shall be fully accomplished as required under the IDO; in areas in which the edge of that 100-foot buffer falls within any public right-of-way, adjacent properties will be included in the notice.”

We have notified the two City recognized associations, as well as Alameda North Valley, who apparently is no longer recognized, Maria Diers, and North Edith. We have also sent notice to the addresses in the buffer area and added other property owner addresses that were not required to be notified.

City Parks and NM United will be out canvassing the area on Saturday with copies of the notice.

To clarify regarding the meeting on Monday, this was not required by the remand, but we wanted to have a neutral facilitator conduct the meeting and prepare the report that goes to EPC. We can discuss whether further discussion is needed beyond the Monday meeting.

I've copied the two meeting facilitators, Phillip and Tyson, on this email as well as the case planner, Silvia. If you have further questions about the facilitated meeting, remand process, or the EPC hearing, please direct to them.

Jackie Fishman, AICP  
Principal

---

**From:** Jackie Fishman <fishman@consensusplanning.com>

**Sent:** Wednesday, February 28, 2024 2:04 PM

**To:** Pat Hauser <hdhauser@comcast.net>; thummell@cabq.gov <thummell@cabq.gov>; phcrumpsf@gmail.com <phcrumpsf@gmail.com>

**Cc:** Maggie Rose <gypsy.rose46@gmail.com>; Michael Haederle <haederle@yahoo.com>; Steve Wentworth <Anvanews@aol.com>; Peggy Norton <peggynorton@yahoo.com>; Evelyn Harris <grumpyeh46@comcast.net>; Brooke Jordy <brookemjordy@gmail.com>; boyznbari@msn.com <boyznbari@msn.com>; Sandy Zuschlag <szuschlag58@gmail.com>; Steve Taylor <staylor@taylortowers.com>; 'Steve Horchheimer' <stemax1@aol.com>; 'Edie Myers' <emyers\_11@yahoo.com>; t-marie-v@hotmail.com <t-marie-v@hotmail.com>; Christine Benavidez <christinebnvdz@aol.com>; 'Lorraine Montoya' <alamedamontoya@gmail.com>

**Subject:** RE: Balloon Fiesta Park and NM United

Pat –

I agree that the meeting shouldn't be during the day as that would prevent working people from participating. The meeting would be via Zoom and in the evening.

I spoke with Brooke this morning and proposed this coming Monday evening for the facilitated meeting. She was agreeable to that date and so I have notified our team. I'm hoping that is agreeable to you as well.

Our intent is to be back in front of the EPC for the March 21<sup>st</sup> hearing. We are gearing up this afternoon to start sending out notifications today. The representatives from the City recognized associations, as well as representatives from the County neighborhood associations, will be receiving an official email notification today from my office. We are also sending out certified mail notices to all property owners within the 100-foot buffer; that list has been vetted and confirmed with the Planning Department's GIS Manager. We are also sending first class mail to the other property owners that were on your map, everyone who attended any of the seven meetings that provided a mailing address, and every address along the east side of Edith. Parks and Rec will be going door to door with copies of the notice as well. This means some people will likely get 2 or 3 notices in our effort.

I suspect the main agenda item is going to be sound. Let me know if there are specific other items that you would like our team to address.



Please feel free to give me a call to discuss.

Miftxhdq#Lkq dg/DIF  
SubfLsdo  
Frqvhqvzv#Sdqqlj /#qf1  
635 #ljkw#Vwhw#QZ  
Dextxhutxh/#QP #: 435  
S#381:97k;34

---

**From:** Pat Hauser <hdhauser@comcast.net>  
**Sent:** Wednesday, February 28, 2024 11:50 AM  
**To:** Jackie Fishman <fishman@consensusplanning.com>  
**Cc:** Maggie Rose <gypsy.rose46@gmail.com>; Michael Haederle <haederle@yahoo.com>; Steve Wentworth <Anvanews@aol.com>; Peggy Norton <peggynorton@yahoo.com>; Evelyn Harris <grumpyeh46@comcast.net>; Brooke Jordy <brookemjordy@gmail.com>; boyznbari@msn.com; Sandy Zuschlag <szuschlag58@gmail.com>; Steve Taylor <staylor@taylortowers.com>; 'Steve Horschheimer' <stemax1@aol.com>; 'Edie Myers' <emyers\_11@yahoo.com>; t-marie-v@hotmail.com; Christine Benavidez <christinebnvdz@aol.com>; 'Lorraine Montoya' <alamedamontoya@gmail.com>  
**Subject:** RE: Balloon Fiesta Park and NM United

Good morning Ms. Fishman: Thanks for the message regarding the proposed meeting. Your telephone number was blocked on my cellphone as a potential Spam number.  
Not sure why maybe since you are not in my contact list.

Based on my limited knowledge regarding the meeting it would seem as if it is being planned as a Zoom or something of that nature.

My experience has been that if such a meeting is conducted during the day it seriously hampers many individuals from attending due to their business or work schedules.

I would like to contact several of the other Associations and get their input regarding a possible best time to proceed with such a meeting.

It would also be helpful to know the agenda items and what is planned for possible discussion items that will impact we the property owners.

I have taken the liberty to copy several individuals in on our communication regarding a proposed meeting.

Thanks in advance for working with us on this subject.

Regards: Pat Hauser

---

**From:** Jackie Fishman <[fishman@consensusplanning.com](mailto:fishman@consensusplanning.com)>  
**Sent:** Wednesday, February 28, 2024 8:51 AM  
**To:** [hdhauser@comcast.net](mailto:hdhauser@comcast.net)  
**Cc:** [gypsy.rose46@gmail.com](mailto:gypsy.rose46@gmail.com); [phcrumpsf@gmail.com](mailto:phcrumpsf@gmail.com)

**Subject:** Balloon Fiesta Park and NM United

**Importance:** High

Hi Pat –

I left you a voicemail yesterday in regard to the EPC remand. We would like to schedule a meeting to discuss the project and I've copied the meeting facilitator. We are working on notification and have greatly expanded the list of who we will be sending notification to. Given the number of associations and individuals involved, I would like to work with you to pick a meeting date next week and then my office will add the date to the notification. Could you or Maggie please either email me back or call me to discuss your availability next week?

Thanks, and hope to hear from you soon.

Miftxhch#l kq dq#DIF5

SubfIsdo

Frqvhqvzv#Solqqlj /#qf1

635#lj kw#vwhw#QZ

Dextxhutxh#QP #: 435

S#381: 97k ; 34

**From:** Jackie Fishman  
**To:** Sandy Zuschlag  
**Cc:** Flores, David M.; Simon, David J.; Bolivar, Silvia A.  
**Subject:** Re: March 4th Zoom Meeting  
**Date:** Wednesday, March 6, 2024 7:58:57 PM

---

[EXTERNAL] Forward to [phishing@cabq.gov](mailto:phishing@cabq.gov) and delete if an email causes any concern.

Sandy - I'm out until Monday, so just a quick email to say that if you submitted your letter to Silvia Bolivar, it is part of the record and is already going to be included in the staff report. Staff reports are posted the week before the hearing, March 14, so all letters received before then are included.

Lastly, the facilitators are hired strictly to facilitate the meeting and create a report of the discussion at the meeting to provide to the EPC. They don't make any determination or judgement on anything. The facilitators have never accepted a letter from anyone - its simply not part of facilitation process.

There is a lot of misunderstanding out there regarding the City's legal entitlements process. I would encourage you to contact the Planning Department.

Jackie Fishman, AICP  
Principal

---

**From:** Sandy Zuschlag <szuschlag58@gmail.com>  
**Sent:** Wednesday, March 6, 2024 9:06 AM  
**To:** Jackie Fishman <fishman@consensusplanning.com>  
**Cc:** David Flores (DFlores@cabq.gov) <DFlores@cabq.gov>; Simon, David J. <dsimon@cabq.gov>; Silvia A. Bolivar <salivar@cabq.gov>  
**Subject:** Re: March 4th Zoom Meeting

Jackie thank you for your response. I hope AGIS and Planning will correct their database so this doesn't happen again. Please provide me an update when this has been corrected. Is this the only area which this has occurred or city wide?

Concerning notification, I understand what you are saying but I find it incredibly frustrating that I brought the notification issue and other issues to the attention of you and COA staff and I have been blown off. From what I have observed that is happening with the neighbors too.

Concerning the March 4th letter, I still would like it to show up as part of the record. Why was this not allowed, where does it show up in IDO? I asked current process questions in my email to you last week and in the March 4th letter which should be addressed now.

While I will submit comments again to EPC that is not until March 11th? Right? What time? No where in the minutes does it state a day and time. Is it ten business or working days?

I look forward to your response.

Sent from my iPhone

On Mar 6, 2024, at 9:17 AM, Jackie Fishman <fishman@consensusplanning.com> wrote:

Sandy –

My understanding from Phillip Crump is that he advised you to send your letter to Silvia Bolivar (City case planner) so that it can be properly entered into the case record. All letters sent to Silvia will be part of the staff report that goes to the EPC.

I also wanted to respond to what I think is a misunderstanding regarding what I said in a previous email about notification. I certainly acknowledge that you called me to express your concern regarding notification of property owners along Edith Boulevard. If you recall, I sent you the notification list. You should understand that I don't personally create the buffer map – my staff does. At the time, I asked my staff to check the buffer map and was assured that it was drawn correctly. The addresses are automatically created by AGIS, as I tried to explain to you previously. There is no explanation as to why the system didn't work correctly - the Planning Department also had no explanation. Our case planner also believed that notification was done properly, as noted in the staff report. And as you know, once the mistake was made abundantly clear, the Applicants requested the remand. I can assure you that there was no ill intent to leave anyone out of this process. The case has been remanded and everyone who has a desire to participate will have the opportunity to do so.

Thanks and have a great vacation,

Jacqueline Fishman, AICP  
Principal  
Consensus Planning, Inc.  
302 Eighth Street NW  
Albuquerque, NM 87102  
P: 505.764.9801

---

**From:** Sandy Zuschlag <szuschlag58@gmail.com>  
**Sent:** Tuesday, March 5, 2024 7:43 AM  
**To:** Phillip Crump <phcrumps@gmail.com>; Jackie Fishman <fishman@consensusplanning.com>; David Flores <DFlores@cabq.gov>; David Simon <dsimon@cabq.gov>  
**Cc:** Brooke Jordy <brookemjordy@gmail.com>; Michael Haederle <haederle@yahoo.com>; Steve Wentworth <swent999@aol.com>; Kenneth & Evelyn Harris <grumpyeh46@comcast.net>; Maggie Rose <gypsy.rose46@gmail.com>; Pat Hauser <hdhauser@comcast.net>  
**Subject:** March 4th Zoom Meeting

March 5, 2024

Good morning,

I have heard that the email I sent yesterday was not included in the record for the meeting last night. I sent it about 11:30 am ABQ time. Why was it not included?

To say I am disappointed is an understatement. I spent a couple of hours working on my comments and sending them from the iPad was difficult. I am outside the country and I still spent the time to comment and try and participate.

Wow...

Sent from my iPhone

Begin forwarded message:

**From:** Sandy Zuschlag <szuschlag58@gmail.com>

**Date:** March 4, 2024 at 12:26:35 PM CST  
**To:** Philip Crump <phcrumpsf@gmail.com>  
**Cc:** Pat Hauser <hhauser@comcast.net>, Tina Villegas <tmarie-v@hotmail.com>, Brooke Jordy <brookemjordy@gmail.com>, Michael Haederle <haederle@yahoo.com>, Maggie Rose <gypsy\_rose46@gmail.com>, Kenneth & Evelyn Harris <grumpyeh46@comcast.net>, "Tania and Mike (Luis) Gonzalez (maiden Serafin)" <Tserafin30@gmail.com>  
**Subject:** Re: March 4th Zoom Meeting

Phil, I think the following reference should state ambient plus 5 dBA not 50 dB:

FOR REFERENCE ONLY: Where local ambient noise levels exceed 50 dBA, the maximum noise level criteria shall be ambient plus 50 dBA

Sent from my iPhone

On Mar 4, 2024, at 12:04 PM, Sandy Zuschlag <szuschlag58@gmail.com> wrote:

March 4, 2024

Hello, my name is Sandy Zuschlag. Unfortunately it is impossible for me to participate in the meeting tonight since I am outside of the country and I do not have access to the zoom meeting. Please include these comments as part of the record for the meeting tonight. I apologize for any formatting/ grammar problems since I am preparing this on my iPad and it has been challenging.

Also, I would like to receive a copy of the minutes when they are completed.

I am a retired licensed landscape architect. I worked for the City Parks and Recreation Department for almost 30 years. In 2012, I retired as the Assistant Director. I started working on Balloon Fiesta Park in the late 1980's through 2012. In 2013, AIBF asked me to help develop two programs in regard to event management for the North Edith and Marie Diers neighborhoods.

1. Neighborhood outreach, and
2. A sound monitoring and management program

Today, I am **not** representing AIBF in my comments, I am here to share my personal and professional observations. Over the last ten years during the Balloon Fiesta, we have recorded roughly 300 sound monitoring records yearly, or over 3,000 readings in ten years. Our sound reading locations are in the North Edith and Marie Diers neighborhoods. In exhibit B from the Remand Hearing those locations are documented.

**I am opposed to the stadium being located at Balloon Fiesta Park due to the negative environmental impacts on the surrounding communities. From my experience of monitoring sound and other neighborhood impacts during the Balloon Fiesta the impact on the surrounding neighborhoods will be severe.**

On March 1<sup>st</sup> I sent an email response to Jackie Fishman's Feb. 29<sup>th</sup> email about the proposed stadium project. I copied David Simon and David Flores, the director and deputy director of the COA Parks and Recreation Department on my email. While it hasn't been that many days for a response from the consultants and the City representatives, the aggressive planning schedule established by the City requires speedy and clear responses to questions.

Since I have not received a response, here are my questions again. Based on the poor communication that has occurred for this project it is difficult to know if any comments or suggestions have been considered.

March 1<sup>st</sup> email: It appears from Ms. Fishman's comments the approach to this remand is viewed as a technical step, not a real effort to listen and work together. I am not sure how the record gets corrected but there were several deficiencies that would have been addressed at the Remand Hearing. I understood that Mr. Chavez's ruling was a de novo, or the planning for the project had to start over. This current "planning" approach again misses the point that the neighbors living around Balloon Fiesta Park have multiple concerns. It isn't "just about noise" which in itself is a significant issue. How is one hastily scheduled meeting and setting the EPC Hearing date without listening to people demonstrate a willingness to work together?

For the consultant to now indicate that the lack of notification was a technical problem and that a meeting was not required per the remand is setting the stage for another round of poor attempts to communicate. Mr. Chavez's ruling was a do over from the beginning. Where are City staff reports?

Many individuals have provided multiple written comments that have not been addressed by the City, Consensus Planning or United New Mexico. This again shows a true lack of interest to address the concerns about the proposed stadium project. Why hasn't this happen, because it is "not required"? I would recommend that those comments be reread and addressed in writing to ensure good communication.

Ms. Fishman stated "the remand is based on the seven property owner addresses that were **inexplicably** not included in the original notice of hearing last October". This is an incorrect statement. In October and November, prior to the EPC hearing on several occasions I reached out to Ms. Fishman via phone calls and emails about not all of the neighbors within the 100 foot buffer not being notified. My comments were not taken seriously; just like comments are not being taken seriously now. The Hearing Officer said this was a de novo hearing, how is this a "do over" when the consultants are saying a meeting wasn't required?

Questions I have about this "process" are:

1. Are the comments made in the original hearing process part of the record of this "do over"? How are inaccuracies in the reporting from the original case addressed?
2. Are the exhibits which were part of the Remand Hearing included in the new case?
3. When are the written comments due for the planned EPC Hearing on March 21<sup>st</sup>?
4. What will be the format for the EPC hearing? Allowing two minutes for persons to speak doesn't allow adequate time.

**Additional Comments:**

**A. Amplified sound during the Balloon Fiesta:**

In 2015, we developed Standard Operating Procedures concerning event sound management for the Balloon Fiesta. These standards were

developed in coordination with the following:

- COA Environmental Health and the Parks & Recreation Department
- AIBF staff
- AIBF's sound consultant, Noise Experts

The standards were based on the review of:

- 2012 Balloon Fiesta Park Master Plan
- 2017 COA - Noise Control Ordinance
- BERNCO - Noise Ordinance

On page 457 of the original EPC report are my 19 pages of comments. I also submitted multiple pages of comments concerning the lease. On page 469 of the EPC report is a copy of the Standard Operating Procedures and the analysis of the ordinances and plan.

The bottom line is during the Balloon Fiesta we were hired and authorized by AIBF to contacted the AIBF sound board staff to turn the amplified sound down when:

**Daytime amplified sounds (7 AM – 10 PM) are above 56 dB and,**

**Nighttime amplified sounds (10 PM – 7 AM) are above 51 dB.**

**The United New Mexico sound study showed amplified sounds from the stadium above these requirements, it also did not address how sounds would be controlled before 10 PM.** Impacts from non-amplified event sounds were also not addressed. What are the plans to manage sound from the stadium? Elevated amplified sounds from events at the park can be heard clearly along Second Street and beyond which is more than a mile away from the park.

**B. Neighborhood Involvement with the North Edith Corridor NA, the closest NA to the park:** See Exhibit D from the Remand Hearing – Chronology, on November 7<sup>th</sup>, page 10, was the first time Consensus Planning contacted the North Edith Corridor Neighborhood Association about meeting to discuss the proposed stadium. I approached Consensus Planning to let them know there was a scheduling conflict with the Marie Diers and North Edith Corridor NAs. Ms. Fishman indicated that the meeting was a follow-up meeting with the Wildflower NA. Michael Haederle, the vice president of the North Edith Corridor NA, commented in an email, *“Thanks, Sandy, that’s exactly when our neighborhood meeting is scheduled. It’s curious that Consensus Planning still hasn’t contacted our association directly.”*

Consensus Planning then scheduled a meeting for November 15<sup>th</sup> (the night before the EPC hearing) with the North Edith Corridor and Marie Diers NA. If meeting with the neighbors was necessary, it would have occurred sooner. Not the night before the hearing.

Also, the November 15<sup>th</sup> meeting minutes were never entered into the record as part of the original appeal. Page 003 of the appeal package stated, *“Appellants believe City staff neglected to refer to the strong and nearly unanimous opposition expressed by neighbors at the November 15, 2023 meeting.”* The meeting minutes do not accurately describe the many adverse comments stated. Specifically, no mention is made concerning the discussion about adding a roof to the stadium to control the sound, noise and light pollution.

In the original EPC package and minutes from the hearing, the attendees of the meetings are sometimes listed incorrectly and not all of the concerns from the neighbors were documented. At the EPC hearing, a speaker in support of the stadium stated they lived west of Balloon Fiesta. Their address was off Second Street south of Osuna Road. Clearly they do not live directly west of the park.

**100-foot Buffer Notification: See Remand Exhibit C and Chronology, Exhibit D - page 3:** Concerning this issue, email communication starting October 10<sup>th</sup> between Ms. Fishman and me. Not setting the records straight on this important issue compromises the ability for future meaningful discussions.

#### **D. Environmental Impacts of Building a Stadium at Balloon Fiesta Park and the “Arbitrary and Capricious” Manner of Planning for the Proposed Stadium:**

1. **Balloon Fiesta Park Commission:** A critical component of Balloon Fiesta Park Master Development was public involvement. The public involvement was formalized through the creation of the Balloon Fiesta Park Commission. In the adopted plan, there are roughly 30 references concerning how the Commission should be involved in the park's planning, development, and operations. Since 2018, the Commission has not had a quorum. The **arbitrary** decision of the City precluded the required review of the update of the BF Park Master Development Plan.

2. **Large Outdoor Performance Center and the Balloon Fiesta Park Commission:** In the EPC Minutes, page 568, paraphrasing Ms. Fishman, she said, *“In my opinion, it's (the proposed Large Outdoor Performance Center) is not that dissimilar to the proposed multi-use stadium. And it included significant sound and lighting as key design elements. The park itself has always been envisioned as a very active facility.”* Quoting from the 2012 Master Plan, *“The Large Outdoor Performance Area shall require the typical site development plan approval process by the EPC, including notification to area neighborhood associations and adjacent landowners. In addition to the EPC approval process, the design of this facility, particularly regarding the stage height, shall require consultation with and approval by the FAA, AIBF, City Parks and Recreation, and the Balloon Fiesta Park Commission.”*

**Yes, the two projects are similar; in this example, the consultant did not include the need for extensive involvement in reviewing significant proposed improvements at the park—another example of an arbitrary decision. The EPC process should not be viewed as a rubber stamp.**

**E. Design Process – existing conditions:** As part of a design process, existing conditions are considered. The existing conditions were not adequately addressed when proposing a stadium at Balloon Fiesta Park. If they had, they would have realized the **current** impact Balloon Fiesta Park has had on the surrounding neighborhoods regarding sound and other environment impacts.

#### **F. “Sound Study,” Anthony James Partners, New Mexico United Soccer Stadium:**

1. Page 330, Methodology: the consultant stated that based on GPS Topographical information, the area is a **“relatively flat terrain”**. This is an incorrect statement since it does not address:

- North Diversion Channel (the paved channel which acts as a conduit conveying event sounds westward)
- An elevation change of 40 to 50 feet from the proposed stadium location to the residential areas west of the park
- The extension of the eastern escarpment northward which helps to direct amplified event sounds north and westward.
- The Sound Consultant indicated the location of the North Edith neighborhoods as 2,550 feet. From Google Maps, 10212 Edith Blvd. is about 2,059 feet.

2. **Test Process, page 326:** “Acoustical noise level standard published in the COA and BERNCO Noise Ordinances”:

- FOR REFERENCE ONLY: Maximum noise levels at noise-sensitive property line shall not exceed 50 dBA between the hours of 10 pm and 7 am
- FOR REFERENCE ONLY: Where local ambient noise levels exceed 50 dBA, the maximum noise level criteria shall be ambient plus 50 dBA.
- Amplified sound is allowed between hours of 7 am – 10 pm
- FOR REFERENCE ONLY: No person in the stadium shall be exposed to amplified sound over 90 dBA.

**Page 569, EPC Minutes, Jackie Fishman:**

“So this is a graphic from the sound analysis. The city's noise ordinance and the master development plan restrict amplified sound from 7:00 a.m. to 10:00 p.m., so that's important to note. The stadium and the games played there will be 17 in their season; they are played on Saturdays from 7:00 p.m. to 9:00 p.m. So they will end before the restricted 10:00 p.m. deadline.”

**COMMENT: These statements do not address the COA Noise Ordinance, Table 1: Receptor Property, Daytime – Residential as 55 dB. The sound study projects sound levels is 52 to 59 dB. THESE PROJECTED SOUND LEVELS ARE ABOVE THE COA NOISE ORDINANCE.**

**The consultants and the City have not addressed these issues—another arbitrary decision. I recommend a new Sound Study and the consultants should contact me to discuss the real world sound results we have documented.**

**G. Light Pollution:** Refer to Exhibits provided in the Remand Hearing; look at the view from the top of Gondola Gulch. Many homes along Edith Blvd., the North Valley, Westside Albuquerque, and Rio Rancho have a view of Balloon Fiesta Park. While the Musco lighting study addresses the light quality on the field and the immediate area, it does not address the elevation change between the proposed stadium lights and the neighborhoods to the south, north and west. The Stadium lights are between 80 and 100 feet tall. The neighborhoods to the west are 40 to 50 feet below the playing field for the stadium. **Will the lights shine into Tina's Villegas's bedroom window, 10212 Edith Blvd. and beyond? The Musco lighting study does not address this issue. Again, this is another arbitrary decision not to address the full impact the lights will have on the community. This design issue deserves additional discussion and attention. Once the lights are installed, it will be too late.**

When the golf center range lights were installed at the park, the Parks and Recreation Department received many complaints from residents in the city, Rio Rancho and Corrales. We had to adjust the lights downward. The proposed stadium lights are taller and will effect more community neighborhoods. The lighting study should address this issue.

In closing, please postpone the planned March 21, 2024, EPC Hearing Date concerning the proposed stadium. One zoom meeting does not provide the opportunity for a productive meeting and negotiations concerning this project. Additional meetings and discussions are needed to sufficiently address these and other important issues. The City has received many adverse comments for this project and to date has not addressed them.

Should my request for a delay not be granted, please refer to Mr. Chavez's ruling. This was a “do over” hearing, not a technical step in the process. How can all parties understand each other when the ground rules are so unclear?

Thank you,

Sandra Zuschlag,  
8105 Irwin Street NE  
505-250-3798

Sent from my iPad



**From:** Bolivar, Silvia A.  
**To:** Sandy Zuschlag  
**Subject:** RE: March 4th Zoom Meeting - propped Stadium at Balloon Fiesta Park  
**Date:** Wednesday, March 6, 2024 8:58:00 AM

Good morning Mrs. Zuschlag,

I have created a PDF containing the comments submitted for inclusion in the facilitated meeting scheduled for March 4, 2024. This PDF will be incorporated into the staff report, allowing Chair Hollinger and the EPC commissioners to review your comments.

If you require any further assistance, please do not hesitate to reach out.

Silvia

**ONE**  
**ALBUQUE** planning  
**RQUE**  
SILVIA BOLIVAR, PLA ASLA  
Senior Planner  
Landmarks Commission  
(505) 924-3844  
Email: [sabolivar@cabq.gov](mailto:sabolivar@cabq.gov)  
[cabq.gov/planning](http://cabq.gov/planning)

**From:** Sandy Zuschlag <[szuschlag58@gmail.com](mailto:szuschlag58@gmail.com)>  
**Sent:** Tuesday, March 5, 2024 9:44 PM  
**To:** Bolivar, Silvia A. <[sabolivar@cabq.gov](mailto:sabolivar@cabq.gov)>  
**Subject:** Re: March 4th Zoom Meeting - propped Stadium at Balloon Fiesta Park

[EXTERNAL] Forward to [phishing@cabq.gov](mailto:phishing@cabq.gov) and delete if an email causes any concern.

Thanks Phil, I wish Jackie would have heard me when I told her...

Sent from my iPhone

On Mar 5, 2024, at 5:51 PM, Sandy Zuschlag <[szuschlag58@gmail.com](mailto:szuschlag58@gmail.com)> wrote:

March 5th

Hello Sylvia,

I am out of the country for a month and I could not participate via the zoom meeting yesterday. As you know I am very interested in this issue.

Yesterday morning I sent my comments to Philip Crump, but he did include my comments for the meeting. This is very frustrating.

Last week I sent an email to Jackie and the P&R directors about questions I had about the process. No one has responded. Could you look at my comments and please clarify the process? Also, I am requesting again my comments be included in the notes for the meeting.

Sent from my iPhone

Begin forwarded message:

**From:** Sandy Zuschlag <[szuschlag58@gmail.com](mailto:szuschlag58@gmail.com)> in the re  
**Date:** March 5, 2024 at 10:30:58 AM CST  
**To:** "Morris, Petra" <[pmorris@cabq.gov](mailto:pmorris@cabq.gov)>  
**Cc:** "Schultz, Shanna M." <[shanna@cabq.gov](mailto:shanna@cabq.gov)>, Planning EPC <[PlanningEPC@cabq.gov](mailto:PlanningEPC@cabq.gov)>, "Cox, Matthew D." <[mcox@cabq.gov](mailto:mcox@cabq.gov)>  
**Subject:** Re: March 4th Zoom Meeting - propped Stadium at Balloon Fiesta Park

Thank you Petra,

commenting and having people listen shouldn't be this hard

Sent from my iPhone

On Mar 5, 2024, at 9:39 AM, Morris, Petra <[pmorris@cabq.gov](mailto:pmorris@cabq.gov)> wrote:

Good morning Sandy,

Thank you for reaching out. I have added the Planning Department's EPC email address to the email chain.

Planning staff, please include this email chain and Sandy's comments below for the proposed stadium at Balloon Fiesta Park.

Kind regards,

**Petra Morris, AICP**  
Associate Director of Planning & Policy Development  
Albuquerque City Council  
505.768.3161  
[pmorris@cabq.gov](mailto:pmorris@cabq.gov)

<image001.png>

**From:** Sandy Zuschlag <[szuschlag58@gmail.com](mailto:szuschlag58@gmail.com)>  
**Date:** Tuesday, March 5, 2024 at 8:37 AM  
**To:** "Schultz, Shanna M." <[shanna@cabq.gov](mailto:shanna@cabq.gov)>  
**Cc:** "Cox, Matthew D." <[mcox@cabq.gov](mailto:mcox@cabq.gov)>, "Morris, Petra" <[pmorris@cabq.gov](mailto:pmorris@cabq.gov)>  
**Subject:** Re: March 4th Zoom Meeting - propped Stadium at Balloon Fiesta Park

[EXTERNAL] Forward to [phishing@cabq.gov](mailto:phishing@cabq.gov) and delete if an email causes any concern.

Thank you for your response. I look forward to hearing from Matt or Petra.

Sent from my iPhone

On Mar 5, 2024, at 9:31 AM, Schultz, Shanna M. <[shanna@cabq.gov](mailto:shanna@cabq.gov)> wrote:

Hi Sandy,

I no longer work for the City Council, so I'm not the best person to help you navigate getting communications to the Councilors. I've copied Matt Cox and Petra Morris on this e-mail, both of which work for Council and should be able to assist.

Thank you,  
Shanna

<image001.png>

**Shanna Schultz, AICP**  
Policy + Government Affairs Administrator  
office of policy  
c 505.569.9923  
[shanna@cabq.gov](mailto:shanna@cabq.gov)

---

**From:** Sandy Zuschlag <[szuschlag58@gmail.com](mailto:szuschlag58@gmail.com)>  
**Date:** Tuesday, March 5, 2024 at 8:02 AM  
**To:** Schultz, Shanna M. <[shanna@cabq.gov](mailto:shanna@cabq.gov)>  
**Subject:** March 4th Zoom Meeting - propped Stadium at Balloon Fiesta Park

[EXTERNAL] Forward to [phishing@cabq.gov](mailto:phishing@cabq.gov) and delete if an email causes any concern.

Good morning Shanna.

I know I can't communicate with my councilor about this issue but I need help from someone.

I am in Costa Rica for the month and I am very interested in the proposed stadium project at Balloon Fiesta. I feel like I am hitting a block wall. I have continued to provide comments about the project but I have not received responses to much of what I have written.

Yesterday I tried to participate in the zoom meeting but it was not possible due to poor service. I sent comments but I understand they were not included in the record. Can you help me in getting my comments included as part of the record? My comments are below. I apologize for formatting problem. Trying to cut and paste information on my iPad has been challenging.

I really appreciate your help since the consultations and P&R staff are not responding to me. I am in Costa Rica until March 26th so attending the EPC hearing will also be challenging.

Sandy  
505-250-3798 (my number works here)

Sent from my iPhone

Begin forwarded message:

**From:** Sandy Zuschlag <[szuschlag58@gmail.com](mailto:szuschlag58@gmail.com)>  
**Date:** March 5, 2024 at 8:43:21 AM CST  
**To:** Philip Crump <[phcrumpsf@gmail.com](mailto:phcrumpsf@gmail.com)>, Jackie Fishman <[fishman@consensusplanning.com](mailto:fishman@consensusplanning.com)>, David Flores <[DFlores@cabq.gov](mailto:DFlores@cabq.gov)>, David Simon <[dsimon@cabq.gov](mailto:dsimon@cabq.gov)>  
**Cc:** Brooke Jordy <[brookemjordy@gmail.com](mailto:brookemjordy@gmail.com)>, Michael Haederle <[haederle@yahoo.com](mailto:haederle@yahoo.com)>, Steve Wentworth <[swent999@aol.com](mailto:swent999@aol.com)>, Kenneth & Evelyn Harris <[grumpyeh46@comcast.net](mailto:grumpyeh46@comcast.net)>, Maggie Rose <[gypsy.rose46@gmail.com](mailto:gypsy.rose46@gmail.com)>, Pat Hauser <[hdhauser@comcast.net](mailto:hdhauser@comcast.net)>  
**Subject:** March 4th Zoom Meeting

March 5, 2024

Good morning,

I have heard that the email I sent yesterday was not included in the record for the meeting last night. I sent it about 11:30 am ABQ time. Why was it not included?

To say I am disappointed is an understatement. I spent a couple of hours working on my comments and sending them from the iPad was difficult. I am outside the country and I still spent the time to comment and try and participate.

Wow...

Sent from my iPhone

Begin forwarded message:

**From:** Sandy Zuschlag <[szuschlag58@gmail.com](mailto:szuschlag58@gmail.com)>  
**Date:** March 4, 2024 at 12:26:35 PM CST  
**To:** Philip Crump <[phcrumpsf@gmail.com](mailto:phcrumpsf@gmail.com)>  
**Cc:** Pat Hauser <[hdhauser@comcast.net](mailto:hdhauser@comcast.net)>, Tina Villegas <[L-marie-v@hotmail.com](mailto:L-marie-v@hotmail.com)>, Brooke Jordy <[brookemjordy@gmail.com](mailto:brookemjordy@gmail.com)>, Michael Haederle <[haederle@yahoo.com](mailto:haederle@yahoo.com)>, Maggie Rose <[gypsy.rose46@gmail.com](mailto:gypsy.rose46@gmail.com)>, Kenneth & Evelyn Harris <[grumpyeh46@comcast.net](mailto:grumpyeh46@comcast.net)>, "Tania and Mike (Luis) Gonzalez (maiden Serafin)" <[TSerafin30@gmail.com](mailto:TSerafin30@gmail.com)>  
**Subject:** Re: March 4th Zoom Meeting

Phil, I think the following reference should state ambient plus 5 dBA not 50 dB:

FOR REFERENCE ONLY: Where local ambient noise levels exceed 50 dBA, the maximum noise level criteria shall be ambient plus 50 dBA

Sent from my iPhone

On Mar 4, 2024, at 12:04 PM, Sandy Zuschlag <[szuschlag58@gmail.com](mailto:szuschlag58@gmail.com)> wrote:

March 4, 2024

Hello, my name is Sandy Zuschlag. Unfortunately it is impossible for me to participate in the meeting tonight since I am outside of the country and I do not have access to the zoom meeting. Please include these comments as part of the record for the meeting tonight. I apologize for any formatting/ grammar problems since I am preparing this on my iPad and it has been challenging.

Also, I would like to receive a copy of the minutes when they are completed.

I am a retired licensed landscape architect. I worked for the City Parks and Recreation Department for almost 30 years. In 2012, I retired as the Assistant Director. I started working on Balloon Fiesta Park in the late 1980's through 2012. In 2013, AIBF asked me to help develop two programs in regard to event management for the North Edith and Marie Diers neighborhoods.

1. Neighborhood outreach, and
2. A sound monitoring and management program

Today, I am **not** representing AIBF in my comments, I am here to share my personal and professional observations. Over the last ten years during the Balloon Fiesta, we have recorded roughly 300 sound monitoring records yearly, or over 3,000 readings in ten years. Our sound reading locations are in the North Edith and Marie Diers neighborhoods. In exhibit B from the Remand Hearing those locations are documented.

**I am opposed to the stadium being located at Balloon Fiesta Park due to the negative environmental impacts on the surrounding communities. From my experience of monitoring sound and other neighborhood impacts during the Balloon Fiesta the impact on the surrounding neighborhoods will be severe.**

On March 1<sup>st</sup> I sent an email response to Jackie Fishman's Feb. 29<sup>th</sup> email about the proposed stadium project. I copied David Simon and David Flores, the director and deputy director of the COA Parks and Recreation Department on my email. While it hasn't been that many days for a response from the consultants and the City representatives, the aggressive planning schedule established by the City requires speedy and clear responses to questions.

Since I have not received a response, here are my questions again. Based on the poor communication that has occurred for this project it is difficult to know if any comments or suggestions have been considered.

March 1<sup>st</sup> email: It appears from Ms. Fishman's comments the approach to this remand is viewed as a technical step, not a real effort to listen and work together. I am not sure how the record gets corrected but there were several deficiencies that would have been addressed at the Remand Hearing. I understood that Mr. Chavez's ruling was a de novo, or the planning for the project had to start over. This current "planning" approach again misses the point that the neighbors living around Balloon Fiesta Park have multiple concerns. It isn't "just about noise" which in itself is a significant issue. How is one hastily scheduled meeting and setting the EPC Hearing date without listening to people demonstrate a willingness to work together?

For the consultant to now indicate that the lack of notification was a technical problem and that a meeting was not required per the remand is setting the stage for another round of poor attempts to communicate. Mr. Chavez's ruling was a do over from the beginning. Where are City staff reports?

Many individuals have provided multiple written comments that have not been addressed by the City, Consensus Planning or United New Mexico. This again shows a true lack of interest to address the concerns about the proposed stadium project. Why hasn't this happen, because it is "not required"? I would recommend that those comments be reread and addressed in writing to ensure good communication.

Ms. Fishman stated "the remand is based on the seven property owner addresses that were **inexplicably** not included in the original notice of hearing last October". This is an incorrect statement. In October and November, prior to the EPC hearing on several occasions I reached out to Ms. Fishman via phone calls and emails about not all of the neighbors within the 100 foot buffer not being notified. My comments were not taken seriously; just like comments are not being taken seriously now. The Hearing Officer said this was a de novo hearing, how is this a "do over" when the consultants are saying a meeting wasn't required?

Questions I have about this "process" are:

1. Are the comments made in the original hearing process part of the record of this "do over"? How are inaccuracies in the reporting from the original case addressed?
2. Are the exhibits which were part of the Remand Hearing included in the new case?
3. When are the written comments due for the planned EPC Hearing on March 21<sup>st</sup>?
4. What will be the format for the EPC hearing? Allowing two minutes for persons to speak doesn't allow adequate time.

#### **Additional Comments:**

##### **A. Amplified sound during the Balloon Fiesta:**

In 2015, we developed Standard Operating Procedures concerning event sound management for the Balloon Fiesta. These standards were developed in coordination with the following:

- COA Environmental Health and the Parks & Recreation Department
- AIBF staff
- AIBF's sound consultant, Noise Experts

The standards were based on the review of:

- 2012 Balloon Fiesta Park Master Plan
- 2017 COA - Noise Control Ordinance
- BERNCO - Noise Ordinance

On page 457 of the original EPC report are my 19 pages of comments. I also submitted multiple pages of comments concerning the lease. On page 469 of the EPC report is a copy of the Standard Operating Procedures and the analysis of the ordinances and plan.

The bottom line is during the Balloon Fiesta we were hired and authorized by AIBF to contacted the AIBF sound board staff to turn the amplified sound down when:

**Daytime amplified sounds (7 AM – 10 PM) are above 56 dB and,**

Nighttime amplified sounds (10 PM – 7 AM) are above 51 dB.

The United New Mexico sound study showed amplified sounds from the stadium above these requirements, it also did not address how sounds would be controlled before 10 PM. Impacts from non-amplified event sounds were also not addressed. What are the plans to manage sound from the stadium? Elevated amplified sounds from events at the park can be heard clearly along Second Street and beyond which is more than a mile away from the park.

**B. Neighborhood Involvement with the North Edith Corridor NA, the closest NA to the park:** See Exhibit D from the Remand Hearing – Chronology, on November 7<sup>th</sup>, page 10, was the first time Consensus Planning contacted the North Edith Corridor Neighborhood Association about meeting to discuss the proposed stadium. I approached Consensus Planning to let them know there was a scheduling conflict with the Marie Diers and North Edith Corridor NAs. Ms. Fishman indicated that the meeting was a follow-up meeting with the Wildflower NA. Michael Haederle, the vice president of the North Edith Corridor NA, commented in an email, “Thanks, Sandy, that’s exactly when our neighborhood meeting is scheduled. It’s curious that Consensus Planning still hasn’t contacted our association directly.”

Consensus Planning then scheduled a meeting for November 15<sup>th</sup> (the night before the EPC hearing) with the North Edith Corridor and Marie Diers NA. If meeting with the neighbors was necessary, it would have occurred sooner. Not the night before the hearing.

Also, the November 15<sup>th</sup> meeting minutes were never entered into the record as part of the original appeal. Page 003 of the appeal package stated, “Appellants believe City staff neglected to refer to the strong and nearly unanimous opposition expressed by neighbors at the November 15, 2023 meeting.” The meeting minutes do not accurately describe the many adverse comments stated. Specifically, no mention is made concerning the discussion about adding a roof to the stadium to control the sound, noise and light pollution.

In the original EPC package and minutes from the hearing, the attendees of the meetings are sometimes listed incorrectly and not all of the concerns from the neighbors were documented. At the EPC hearing, a speaker in support of the stadium stated they lived west of Balloon Fiesta. Their address was off Second Street south of Osuna Road. Clearly they do not live directly west of the park.

**100-foot Buffer Notification: See Remand Exhibit C and Chronology, Exhibit D - page 3:** Concerning this issue, email communication starting October 10<sup>th</sup> between Ms. Fishman and me. Not setting the records straight on this important issue compromises the ability for future meaningful discussions.

**D. Environmental Impacts of Building a Stadium at Balloon Fiesta Park and the “Arbitrary and Capricious” Manner of Planning for the Proposed Stadium:**

1. **Balloon Fiesta Park Commission:** A critical component of Balloon Fiesta Park Master Development was public involvement. The public involvement was formalized through the creation of the Balloon Fiesta Park Commission. In the adopted plan, there are roughly 30 references concerning how the Commission should be involved in the park’s planning, development, and operations. Since 2018, the Commission has not had a quorum. The arbitrary decision of the City precluded the required review of the update of the BF Park Master Development Plan.

2. **Large Outdoor Performance Center and the Balloon Fiesta Park Commission:** In the EPC Minutes, page 568, paraphrasing Ms. Fishman, she said, “In my opinion, it’s (the proposed Large Outdoor Performance Center) is not that dissimilar to the proposed multi-use stadium. And it included significant sound and lighting as key design elements. The park itself has always been envisioned as a very active facility.” Quoting from the 2012 Master Plan, “The Large Outdoor Performance Area shall require the typical site development plan approval process by the EPC, including notification to area neighborhood associations and adjacent landowners. In addition to the EPC approval process, the design of this facility, particularly regarding the stage height, shall require consultation with and approval by the FAA, AIBF, City Parks and Recreation, and the Balloon Fiesta Park Commission.”

**Yes, the two projects are similar; in this example, the consultant did not include the need for extensive involvement in reviewing significant proposed improvements at the park—another example of an arbitrary decision. The EPC process should not be viewed as a rubber stamp.**

**E. Design Process – existing conditions:** As part of a design process, existing conditions are considered. The existing conditions were not adequately addressed when proposing a stadium at Balloon Fiesta Park. If they had, they would have realized the current impact Balloon Fiesta Park has had on the surrounding neighborhoods regarding sound and other environment impacts.

**F. “Sound Study,” Anthony James Partners, New Mexico United Soccer Stadium:**

1. Page 330, Methodology: the consultant stated that based on GPS Topographical information, the area is a “relatively flat terrain”. This is an incorrect statement since it does not address:

- North Diversion Channel (the paved channel which acts as a conduit conveying event sounds westward)
- An elevation change of 40 to 50 feet from the proposed stadium location to the residential areas west of the park
- The extension of the eastern escarpment northward which helps to direct amplified event sounds north and westward.
- The Sound Consultant indicated the location of the North Edith neighborhoods as 2,550 feet. From Google Maps, 10212 Edith Blvd. is about 2,059 feet.

2. **Test Process, page 326:** “Acoustical noise level standard published in the COA and BERNCO Noise Ordinances”:

- FOR REFERENCE ONLY: Maximum noise levels at noise-sensitive property line shall not exceed 50 dBA between the hours of 10 pm and 7 am
- FOR REFERENCE ONLY: Where local ambient noise levels exceed 50 dBA, the maximum noise level criteria shall be ambient plus 50 dBA.
- Amplified sound is allowed between hours of 7 am – 10 pm
- FOR REFERENCE ONLY: No person in the stadium shall be exposed to amplified sound over 90 dBA.

**Page 569, EPC Minutes, Jackie Fishman:**

“So this is a graphic from the sound analysis. The city’s noise ordinance and the master development plan restrict amplified sound from 7:00 a.m. to 10:00 p.m., so that’s important to note. The stadium and the games played there will be 17 in their season; they are played on Saturdays from 7:00 p.m. to 9:00

p.m. So they will end before the restricted 10:00 p.m. deadline.”

**COMMENT:** These statement do not address the COA Noise Ordinance, Table 1: Receptor Property, Daytime – Residential as 55 dB. The sound study projects sound levels is 52 to 59 dB. **THESE PROJECTED SOUND LEVELS ARE ABOVE THE COA NOISE ORDINANCE.**

**The consultants and the City have not addressed these issues—another arbitrary decision. I recommend a new Sound Study and the consultants should contact me to discuss the real world sound results we have documented.**

**G. Light Pollution:** Refer to Exhibits provided in the Remand Hearing; look at the view from the top of Gondola Gulch. Many homes along Edith Blvd., the North Valley, Westside Albuquerque, and Rio Rancho have a view of Balloon Fiesta Park. While the Musco lighting study addresses the light quality on the field and the immediate area, it does not address the elevation change between the proposed stadium lights and the neighborhoods to the south, north and west. The Stadium lights are between 80 and 100 feet tall. The neighborhoods to the west are 40 to 50 feet below the playing field for the stadium. **Will the lights shine into Tina's Villegas's bedroom window, 10212 Edith Blvd. and beyond? The Musco lighting study does not address this issue. Again, this is another arbitrary decision not to address the full impact the lights will have on the community. This design issue deserves additional discussion and attention. Once the lights are installed, it will be too late.**

When the golf center range lights were installed at the park, the Parks and Recreation Department received many complaints from residents in the city, Rio Rancho and Corrales. We had to adjust the lights downward. The proposed stadium lights are taller and will effect more community neighborhoods. The lighting study should address this issue.

In closing, please postpone the planned March 21, 2024, EPC Hearing Date concerning the proposed stadium. One zoom meeting does not provide the opportunity for a productive meeting and negotiations concerning this project. Additional meetings and discussions are needed to sufficiently address these and other important issues. The City has received many adverse comments for this project and to date has not addressed them.

Should my request for a delay not be granted, please refer to Mr. Chavez's ruling. This was a “do over” hearing, not a technical step in the process. How can all parties understand each other when the ground rules are so unclear?

Thank you,

Sandra Zuschlag,  
8105 Irwin Street NE  
505-250-3798

Sent from my iPad

**From:** Sandy Zuschlag  
**To:** Jackie Fishman  
**Cc:** Flores, David M.; Simon, David J.; Bolivar, Silvia A.  
**Subject:** Re: March 4th Zoom Meeting  
**Date:** Wednesday, March 6, 2024 9:06:54 AM

---

[EXTERNAL] Forward to [phishing@cabq.gov](mailto:phishing@cabq.gov) and delete if an email causes any concern.

Jackie thank you for your response. I hope AGIS and Planning will correct their database so this doesn't happen again. Please provide me an update when this has been corrected. Is this the only area which this has occurred or city wide?

Concerning notification, I understand what you are saying but I find it incredibly frustrating that I brought the notification issue and other issues to the attention of you and COA staff and I have been blown off. From what I have observed that is happening with the neighbors too.

Concerning the March 4th letter, I still would like it to show up as part of the record. Why was this not allowed, where does it show up in IDO? I asked current process questions in my email to you last week and in the March 4th letter which should be addressed now.

While I will submit comments again to EPC that is not until March 11th? Right? What time? No where in the minutes does it state a day and time. Is it ten business or working days?

I look forward to your response.

Sent from my iPhone

On Mar 6, 2024, at 9:17 AM, Jackie Fishman <[fishman@consensusplanning.com](mailto:fishman@consensusplanning.com)> wrote:

Sandy –

My understanding from Phillip Crump is that he advised you to send your letter to Silvia Bolivar (City case planner) so that it can be properly entered into the case record. All letters sent to Silvia will be part of the staff report that goes to the EPC.

I also wanted to respond to what I think is a misunderstanding regarding what I said in a previous email about notification. I certainly acknowledge that you called me to express your concern regarding notification of property owners along Edith Boulevard. If you recall, I sent you the notification list. You should understand that I don't personally create the buffer map – my staff does. At the time, I asked my staff to check the buffer map and was assured that it was drawn correctly. The addresses are automatically created by AGIS, as I tried to explain to you previously. There is no explanation as to why the system didn't work correctly - the Planning Department also had no explanation. Our case planner also believed that notification was done properly, as noted in the staff report. And as you know, once the mistake was made abundantly clear, the Applicants requested the remand. I can assure you that there was no ill intent to leave anyone out of this process. The case has been remanded and everyone who has a desire to participate will have the opportunity to do so.

Thanks and have a great vacation,

**Jacqueline Fishman, AICP**  
Principal  
Consensus Planning, Inc.  
302 Eighth Street NW  
Albuquerque, NM 87102  
P: 505.764.9801

---

**From:** Sandy Zuschlag <[szuschlag58@gmail.com](mailto:szuschlag58@gmail.com)>

**Sent:** Tuesday, March 5, 2024 7:43 AM

**To:** Philip Crump <[pchrumpsf@gmail.com](mailto:pchrumpsf@gmail.com)>; Jackie Fishman <[fishman@consensusplanning.com](mailto:fishman@consensusplanning.com)>; David Flores <[DFlores@cabq.gov](mailto:DFlores@cabq.gov)>; David Simon <[dsimon@cabq.gov](mailto:dsimon@cabq.gov)>

**Cc:** Brooke Jordy <[brookemjordy@gmail.com](mailto:brookemjordy@gmail.com)>; Michael Haederle <[haederle@yahoo.com](mailto:haederle@yahoo.com)>; Steve Wentworth <[swent999@aol.com](mailto:swent999@aol.com)>; Kenneth & Evelyn Harris <[grumpyeh46@comcast.net](mailto:grumpyeh46@comcast.net)>; Maggie Rose <[gypsy.rose46@gmail.com](mailto:gypsy.rose46@gmail.com)>; Pat Hauser <[hdhauser@comcast.net](mailto:hdhauser@comcast.net)>

**Subject:** March 4th Zoom Meeting

March 5, 2024

Good morning,

I have heard that the email I sent yesterday was not included in the record for the meeting last night. I sent it about 11:30 am ABQ time. Why was it not included?

To say I am disappointed is an understatement. I spent a couple of hours working on my comments and sending them from the iPad was difficult. I am outside the country and I still spent the time to comment and try and participate.

Wow...

Sent from my iPhone

Begin forwarded message:

**From:** Sandy Zuschlag <[szuschlag58@gmail.com](mailto:szuschlag58@gmail.com)>

**Date:** March 4, 2024 at 12:26:35 PM CST

**To:** Philip Crump <[pchrumpsf@gmail.com](mailto:pchrumpsf@gmail.com)>

**Cc:** Pat Hauser <[hdhauser@comcast.net](mailto:hdhauser@comcast.net)>; Tina Villegas <[L-marie-v@hotmail.com](mailto:L-marie-v@hotmail.com)>; Brooke Jordy <[brookemjordy@gmail.com](mailto:brookemjordy@gmail.com)>; Michael Haederle <[haederle@yahoo.com](mailto:haederle@yahoo.com)>; Maggie Rose <[gypsy.rose46@gmail.com](mailto:gypsy.rose46@gmail.com)>; Kenneth & Evelyn Harris <[grumpyeh46@comcast.net](mailto:grumpyeh46@comcast.net)>; "Tania and Mike (Luis) Gonzalez (maiden Serafin)" <[TSerafin30@gmail.com](mailto:TSerafin30@gmail.com)>

**Subject:** Re: March 4th Zoom Meeting

Phil, I think the following reference should state ambient plus 5 dBA not 50 dB:

FOR REFERENCE ONLY: Where local ambient noise levels exceed 50 dBA, the maximum noise level criteria shall be ambient plus 50 dBA

Sent from my iPhone

On Mar 4, 2024, at 12:04 PM, Sandy Zuschlag <[szuschlag58@gmail.com](mailto:szuschlag58@gmail.com)> wrote:

March 4, 2024

Hello, my name is Sandy Zuschlag. Unfortunately it is impossible for me to participate in the meeting tonight since I am outside of the country and I do not have access to the zoom meeting. Please include these comments as part of the record for the meeting tonight. I apologize for any formatting/ grammar problems since I am preparing this on my iPad and it has been challenging.

Also, I would like to receive a copy of the minutes when they are completed.

I am a retired licensed landscape architect. I worked for the City Parks and Recreation Department for almost 30 years. In 2012, I retired as the Assistant Director. I started working on Balloon Fiesta Park in the late 1980's through 2012. In 2013, AIBF asked me to help develop two programs in regard to event management for the North Edith and Marie Diers neighborhoods.

1. Neighborhood outreach, and
2. A sound monitoring and management program

Today, I am **not** representing AIBF in my comments, I am here to share my personal and professional observations. Over the last ten years during the Balloon Fiesta, we have recorded roughly 300 sound monitoring records yearly, or over 3,000 readings in ten years. Our sound reading locations are in the North Edith and Marie Diers neighborhoods. In exhibit B from the Remand Hearing those locations are documented.

**I am opposed to the stadium being located at Balloon Fiesta Park due to the negative environmental impacts on the surrounding communities. From my experience of monitoring sound and other neighborhood impacts during the Balloon Fiesta the impact on the surrounding neighborhoods will be severe.**

On March 1<sup>st</sup> I sent an email response to Jackie Fishman's Feb. 29<sup>th</sup> email about the proposed stadium project. I copied David Simon and David Flores, the director and deputy director of the COA Parks and Recreation Department on my email. While it hasn't been that many days for a response from the consultants and the City representatives, the aggressive planning schedule established by the City requires speedy and clear responses to questions.

Since I have not received a response, here are my questions again. Based on the poor communication that has occurred for this project it is difficult to know if any comments or suggestions have been considered.

March 1<sup>st</sup> email: It appears from Ms. Fishman's comments the approach to this remand is viewed as a technical step, not a real effort to listen and work together. I am not sure how the record gets corrected but there were several deficiencies that would have been addressed at the Remand Hearing. I understood that Mr. Chavez's ruling was a de novo, or the planning for the project had to start over. This current "planning" approach again misses the point that the neighbors living around Balloon Fiesta Park have multiple concerns. It isn't "just about noise" which in itself is a significant issue. How is one hastily scheduled meeting and setting the EPC Hearing date without listening to people demonstrate a willingness to work together?

For the consultant to now indicate that the lack of notification was a technical problem and that a meeting was not required per the remand is setting the stage for another round of poor attempts to communicate. Mr. Chavez's ruling was a do over from the beginning. Where are City staff reports?

Many individuals have provided multiple written comments that have not been addressed by the City, Consensus Planning or United New Mexico. This again shows a true lack of interest to address the concerns about the proposed stadium project. Why hasn't this happen, because it is "not required"? I would recommend that those comments be reread and addressed in writing to ensure good communication.

Ms. Fishman stated "the remand is based on the seven property owner addresses that were **inexplicably** not included in the original notice of hearing last October". This is an incorrect statement. In October and November, prior to the EPC hearing on several occasions I reached out to Ms. Fishman via phone calls and emails about not all of the neighbors within the 100 foot buffer not being notified. My comments were not taken seriously; just like comments are not being taken seriously now. The Hearing Officer said this was a de novo hearing, how is this a "do over" when the consultants are saying a meeting wasn't required?

Questions I have about this "process" are:

1. Are the comments made in the original hearing process part of the record of this "do over"? How are inaccuracies in the reporting from the original case addressed?
2. Are the exhibits which were part of the Remand Hearing included in the new case?
3. When are the written comments due for the planned EPC Hearing on March 21<sup>st</sup>?
4. What will be the format for the EPC hearing? Allowing two minutes for persons to speak doesn't allow adequate time.

#### **Additional Comments:**

##### **A. Amplified sound during the Balloon Fiesta:**

In 2015, we developed Standard Operating Procedures concerning event sound management for the Balloon Fiesta. These standards were developed in coordination with the following:

- COA Environmental Health and the Parks & Recreation Department
- AIBF staff
- AIBF's sound consultant, Noise Experts

The standards were based on the review of:

- 2012 Balloon Fiesta Park Master Plan
- 2017 COA - Noise Control Ordinance
- BERNCO - Noise Ordinance

On page 457 of the original EPC report are my 19 pages of comments. I also submitted multiple pages of comments concerning the lease. On page 469 of the EPC report is a copy of the Standard Operating Procedures and the analysis of the ordinances and plan.



The bottom line is during the Balloon Fiesta we were hired and authorized by AIBF to contacted the AIBF sound board staff to turn the amplified sound down when:

**Daytime amplified sounds (7 AM – 10 PM) are above 56 dB and,  
Nighttime amplified sounds (10 PM – 7 AM) are above 51 dB.**

**The United New Mexico sound study showed amplified sounds from the stadium above these requirements, it also did not address how sounds would be controlled before 10 PM.** Impacts from non-amplified event sounds were also not addressed. What are the plans to manage sound from the stadium? Elevated amplified sounds from events at the park can be heard clearly along Second Street and beyond which is more than a mile away from the park.

**B. Neighborhood Involvement with the North Edith Corridor NA, the closest NA to the park:** See Exhibit D from the Remand Hearing – Chronology, on November 7<sup>th</sup>, page 10, was the first time Consensus Planning contacted the North Edith Corridor Neighborhood Association about meeting to discuss the proposed stadium. I approached Consensus Planning to let them know there was a scheduling conflict with the Marie Diers and North Edith Corridor NAs. Ms. Fishman indicated that the meeting was a follow-up meeting with the Wildflower NA. Michael Haederle, the vice president of the North Edith Corridor NA, commented in an email, “*Thanks, Sandy, that’s exactly when our neighborhood meeting is scheduled. It’s curious that Consensus Planning still hasn’t contacted our association directly.*”

Consensus Planning then scheduled a meeting for November 15<sup>th</sup> (the night before the EPC hearing) with the North Edith Corridor and Marie Diers NA. If meeting with the neighbors was necessary, it would have occurred sooner. Not the night before the hearing.

Also, the November 15<sup>th</sup> meeting minutes were never entered into the record as part of the original appeal. Page 003 of the appeal package stated, “*Appellants believe City staff neglected to refer to the strong and nearly unanimous opposition expressed by neighbors at the November 15, 2023 meeting.*” The meeting minutes do not accurately describe the many adverse comments stated. Specifically, no mention is made concerning the discussion about adding a roof to the stadium to control the sound, noise and light pollution.

In the original EPC package and minutes from the hearing, the attendees of the meetings are sometimes listed incorrectly and not all of the concerns from the neighbors were documented. At the EPC hearing, a speaker in support of the stadium stated they lived west of Balloon Fiesta. Their address was off Second Street south of Osuna Road. Clearly they do not live directly west of the park.

**100-foot Buffer Notification: See Remand Exhibit C and Chronology, Exhibit D - page 3:** Concerning this issue, email communication starting October 10<sup>th</sup> between Ms. Fishman and me. Not setting the records straight on this important issue compromises the ability for future meaningful discussions.

**D. Environmental Impacts of Building a Stadium at Balloon Fiesta Park and the “Arbitrary and Capricious” Manner of Planning for the Proposed Stadium:**

1. **Balloon Fiesta Park Commission:** A critical component of Balloon Fiesta Park Master Development was public involvement. The public involvement was formalized through the creation of the Balloon Fiesta Park Commission. In the adopted plan, there are roughly 30 references concerning how the Commission should be involved in the park’s planning, development, and operations. Since 2018, the Commission has not had a quorum. The **arbitrary** decision of the City precluded the required review of the update of the BF Park Master Development Plan.

2. **Large Outdoor Performance Center and the Balloon Fiesta Park Commission:** In the EPC Minutes, page 568, paraphrasing Ms. Fishman, she said, “In my opinion, it’s (the proposed Large Outdoor Performance Center) is not that dissimilar to the proposed multi-use stadium. And it included significant sound and lighting as key design elements. The park itself has always been envisioned as a very active facility.” Quoting from the 2012 Master Plan, “*The Large Outdoor Performance Area shall require the typical site development plan approval process by the EPC, including notification to area neighborhood associations and adjacent landowners. In addition to the EPC approval process, the design of this facility, particularly regarding the stage height, shall require consultation with and approval by the FAA, AIBF, City Parks and Recreation, and the Balloon Fiesta Park Commission.*”

**Yes, the two projects are similar; in this example, the consultant did not include the need for extensive involvement in reviewing significant proposed improvements at the park—another example of an arbitrary decision. The EPC process should not be viewed as a rubber stamp.**

**E. Design Process – existing conditions:** As part of a design process, existing conditions are considered. The existing conditions were not adequately addressed when proposing a stadium at Balloon Fiesta Park. If they had, they would have realized the **current** impact Balloon Fiesta Park has had on the surrounding neighborhoods regarding sound and other environment impacts.

**F. “Sound Study,” Anthony James Partners, New Mexico United Soccer Stadium:**

1. Page 330, Methodology: the consultant stated that based on GPS Topographical information, the area is a “**relatively flat terrain**”. This is an incorrect statement since it does not address:

- North Diversion Channel (the paved channel which acts as a conduit conveying event sounds westward)
- An elevation change of 40 to 50 feet from the proposed stadium location to the residential areas west of the park
- The extension of the eastern escarpment northward which helps to direct amplified event sounds north and westward.
- The Sound Consultant indicated the location of the North Edith neighborhoods as 2,550 feet. From Google Maps, 10212 Edith Blvd. is about 2,059 feet.

2. **Test Process, page 326:** “Acoustical noise level standard published in the COA and BERNCO Noise Ordinances”:

- FOR REFERENCE ONLY: Maximum noise levels at noise-sensitive property line shall not exceed 50 dBA between the hours of 10 pm and 7 am
- FOR REFERENCE ONLY: Where local ambient noise levels exceed 50 dBA, the maximum noise level criteria shall be ambient plus 50 dBA.
- Amplified sound is allowed between hours of 7 am – 10 pm
- FOR REFERENCE ONLY: No person in the stadium shall be exposed to amplified sound over 90 dBA.

**Page 569, EPC Minutes, Jackie Fishman:**

“So this is a graphic from the sound analysis. The city’s noise ordinance and the master development plan restrict amplified sound from

7:00 a.m. to 10:00 p.m., so that's important to note. The stadium and the games played there will be 17 in their season; they are played on Saturdays from 7:00 p.m. to 9:00 p.m. So they will end before the restricted 10:00 p.m. deadline."

**COMMENT: These statements do not address the COA Noise Ordinance, Table 1: Receptor Property, Daytime – Residential as 55 dB. The sound study projects sound levels is 52 to 59 dB. THESE PROJECTED SOUND LEVELS ARE ABOVE THE COA NOISE ORDINANCE.**

**The consultants and the City have not addressed these issues—another arbitrary decision. I recommend a new Sound Study and the consultants should contact me to discuss the real world sound results we have documented.**

**G. Light Pollution:** Refer to Exhibits provided in the Remand Hearing; look at the view from the top of Gondola Gulch. Many homes along Edith Blvd., the North Valley, Westside Albuquerque, and Rio Rancho have a view of Balloon Fiesta Park. While the Musco lighting study addresses the light quality on the field and the immediate area, it does not address the elevation change between the proposed stadium lights and the neighborhoods to the south, north and west. The Stadium lights are between 80 and 100 feet tall. The neighborhoods to the west are 40 to 50 feet below the playing field for the stadium. **Will the lights shine into Tina's Villegas's bedroom window, 10212 Edith Blvd. and beyond? The Musco lighting study does not address this issue. Again, this is another arbitrary decision not to address the full impact the lights will have on the community. This design issue deserves additional discussion and attention. Once the lights are installed, it will be too late.**

When the golf center range lights were installed at the park, the Parks and Recreation Department received many complaints from residents in the city, Rio Rancho and Corrales. We had to adjust the lights downward. The proposed stadium lights are taller and will effect more community neighborhoods. The lighting study should address this issue.

In closing, please postpone the planned March 21, 2024, EPC Hearing Date concerning the proposed stadium. One zoom meeting does not provide the opportunity for a productive meeting and negotiations concerning this project. Additional meetings and discussions are needed to sufficiently address these and other important issues. The City has received many adverse comments for this project and to date has not addressed them.

Should my request for a delay not be granted, please refer to Mr. Chavez's ruling. This was a "do over" hearing, not a technical step in the process. How can all parties understand each other when the ground rules are so unclear?

Thank you,

Sandra Zuschlag,  
8105 Irwin Street NE  
505-250-3798

Sent from my iPad

March 10, 2024

Environmental Planning Commission City of Albuquerque

C/O Silvia Bolivar sabolivar@cabq.gov [PlanningEPC@cabq.gov](mailto:PlanningEPC@cabq.gov)

VIA ELECTRONIC MAIL

Dear Ms. Bolivar:

Please register my full opposition to the planned soccer stadium at the Balloon Fiesta Park. Having lived in Alameda and close to the Balloon field for over 20 years, I am speaking from experience. Many events that take place at the site have extreme negative impacts on this area. The worst experiences we have are fireworks and noise from bands. Events that take place in the evening have an increased impact on our lives.

I welcome anyone to come to my house during Freedom 4<sup>th</sup> and sit with me and my trembling pets while bombs are exploding overhead. The pets are afraid to go outside to take care of business because of this. I have it easy. Those with farm animals (horses, goats, etc.) have it worse. The fireworks are so explosive that they rattle our homes and windows. They actually cause cracks in our homes.

As for the music, imagine having guests for a weekend dining out on the patio, and being assaulted with music that is not of your taste. The music as it reverberates into our neighborhood comes as pounding noise, with little to enjoy even if it is in your genre.

So far, we have been able to cope with some of these intrusions because they are infrequent and predictable. The Balloon Fiesta is a 9 day event. We can plan for the event. My understanding is that United plans for approximately 17 games per year, plus they want to open it to multiuse events. Having read the lease, there are no prohibitions as to quantity of events, nor limitations as to time of day, fireworks, alcohol sales, tail gating, etc.

Other concerns here are light pollution and the losing our view. Recently someone built bleachers that have had an impact on some people along Edith. A physical obstruction is bad, but, imagine what light pollution will do to our night sky.

The stadium will not be in harmony with the neighborhood which is rural, with small farms and livestock. Alameda is an old historic community. I wonder if the fact that most of the neighbors are in the County and not within the City limits is a factor in pushing this site. City voters already nixed the previous proposals.

Why not look to other areas? There is Mesa del Sol as well as areas off of the Rio Puerco. Mesa del Sol has already proven it can handle the traffic since they host concerts. Rio Rancho is another ideal site which would probably welcome such a venue. It is consistently lauded as a crime free and growing community

In as much as I am against the stadium as proposed, I can see that some changes would lessen the impact to this area and would make it more acceptable to me:

1. Put a lid on it. A roof would eliminate noise and fireworks. I've been told that a roof is too expensive. If United can't afford the project, maybe they should reconsider.
2. Any lighting outside of a roof should be directed away from the neighborhoods of concern.
3. Eliminate alcohol sales and tail gating.
4. Renegotiate the lease to specifically address our concerns.

Thank you for your time and consideration of my comments,

Sarah Shortle, 126 Maria Cir, NW, Albuquerque, NM 87114

## Some thoughts on the United Soccer Stadium.

Has your committee thought about the “impact” of the fireworks on the animals and the environment?

Here are some things to think about.

### EFFECT ON ANIMALS

Many people enjoy the booming sounds and flashing colors of fireworks, but they can be terrifying, overwhelming and hazardous for both wild and domestic animals.

On the Fourth of July, many animals become so frightened by the noise and commotion of fireworks that they run from otherwise familiar environments and people, and sadly become lost. They may also suffer devastating or even fatal health effects from the stress. The sudden bright flashes and sounds can cause wild animals to run into roadways, resulting in more car accidents than normal. Wildlife rehabilitation centers are often flooded with traumatized, injured and orphaned wild animals after the holiday.

Predatory birds, like bald eagles, see the harsh sounds and lights from fireworks as a threat, and may abandon their nests or habitats entirely. The explosions may cause other birds to take off en masse for prolonged periods of time and to use up vital energy reserves needed for survival. Fireworks have even frightened birds into flying so far out to sea that they did not have the energy to make the return flight. Wild birds frightened by the noise of fireworks will also fly higher and for longer, which exposes them to the harmful cocktail of ingredients in fireworks like ozone, sulfur dioxide and nitric oxide that have caused cardiovascular and respiratory damage, and even death, in humans.

Casings and heavy metals that are littered by fireworks are often mistakenly consumed by wildlife or even fed to their young. Many of these materials are either indigestible and therefore choking hazards, or toxic to the animal, and pollutants from fireworks can be washed into waterways and contaminate drinking water for the animals that rely on it. And in regions of the country prone to wildfires, the slightest ember from a fireworks display can start a blaze that kills many wildlife species and destroys their habitats.

Humans, the residents in the area will be faced with loud fireworks in the evenings affecting family time. Try putting children to bed with the loud banging coming from the stadium.

<https://www.humanesociety.org/resources/fireworks-explosion-fear-animals>

### EFFECT ON THE ENVIRONMENT

Nitrogen and sulfur, used to create color and special effects, can combine with oxygen to form nitric and sulfuric acids which are very hard on the lungs. The smoke from the displays generally dissipates within a few hours, but individuals may feel lingering health effects.

What toxins are released by fireworks?

A case study found that within 1 hour of fireworks displays, strontium levels in the air increased 120 times, magnesium 22 times, barium 12 times, potassium 11 times, and copper (Cu) 6 times more than the amount already present in the air before the event (ref). Dec 31, 2019

What environmental damage is caused by fireworks?

Additionally, to produce the oxygen needed for an explosion, many fireworks contain oxidisers known as perchlorates. These can dissolve in water, contaminating rivers, lakes and drinking water. Finally, fireworks release a fine cloud of smoke and particulate matter, affecting local air quality.

Has your committee thought about the “impact” of the artificial lighting on the animals and residents?

#### EFFECT ON RESIDENTS

The use of artificial light at night-time has been linked to increased risk of sleep disorders, obesity, depression, metabolic disorders, and even breast cancer. Humans have evolved to develop a circadian rhythm of being awake during the day and asleep at night.

Children need quiet, good night sleep to grow.

#### EFFECT ON WILDLIFE AND ENVIRONMENT

Artificial light has several general effects on wildlife: Attracts some organisms (moths, frogs, sea turtles), resulting in them not being where they should be, concentrating them as a food source to be preyed upon, or just resulting in a trap which exhausts and kills them.

The effects of night lighting on wildlife have been known for hundreds, even thousands, of years. Hunters and fishers have used torches, lamps, and other light sources to attract their quarry to them, so powerful is the effect of light on some species. Gas-lit lighthouses have long had the reputation of attracting marine birds by the thousands, as well. But only in the past century, with the advent and spread of electricity, has the problem of artificial night lighting become so pervasive.

All animals and plants on this planet (including humans) are genetically adapted to regular day/night/seasonal cycles that have, in many places on the planet, been completely interrupted by the glow created by artificial lights. Although some animals may capitalize on the lighting, many suffer its effects, and one hundred years is not enough time to genetically adapt to these changes.

Artificial light has several general effects on wildlife:

Attracts some organisms (moths, frogs, sea turtles), resulting in them not being where they should be, concentrating them as a food source to be preyed upon, or just resulting in a trap which exhausts and kills them.

Repels some organisms, excluding them from habitat where they might otherwise make a living. Makes it a form of habitat loss.

Alters the day/night patterns, resulting in not getting enough sleep, not having enough down time for the body to repair itself, alters reproductive cycles.

Humans can go inside and turn out the lights to prevent these issues, but the frogs in the pond by the streetlamp can't. For animals that are very site specific, it's not an option to move. They just get eaten, or fail to reproduce. For those that can move, as more and more lighting encroaches on dark areas, the areas that are dark enough to move to become fewer and further between. Artificial lighting is another form of habitat loss.

<https://myfwc.com/conservation/you-observe/lighting/pollution/>

**From:** [Steve Taylor](#)  
**To:** [Bolivar, Silvia A.](#); [Planning EPC](#)  
**Subject:** comments for upcoming hearing regarding United Stadium  
**Date:** Saturday, March 9, 2024 10:35:42 AM  
**Attachments:** [fireworks.docx](#)

---

**[EXTERNAL]** Forward to [phishing@cabq.gov](mailto:phishing@cabq.gov) and delete if an email causes any concern.

My concerns are expressed in the attached letter  
Thank you, Steve & Brigitte Taylor

## Some thoughts on the United Soccer Stadium.

Has your committee thought about the “impact” of the fireworks on the animals and the environment?

Here are some things to think about.

### EFFECT ON ANIMALS

Many people enjoy the booming sounds and flashing colors of fireworks, but they can be terrifying, overwhelming and hazardous for both wild and domestic animals.

On the Fourth of July, many animals become so frightened by the noise and commotion of fireworks that they run from otherwise familiar environments and people, and sadly become lost. They may also suffer devastating or even fatal health effects from the stress. The sudden bright flashes and sounds can cause wild animals to run into roadways, resulting in more car accidents than normal. Wildlife rehabilitation centers are often flooded with traumatized, injured and orphaned wild animals after the holiday.

Predatory birds, like bald eagles, see the harsh sounds and lights from fireworks as a threat, and may abandon their nests or habitats entirely. The explosions may cause other birds to take off en masse for prolonged periods of time and to use up vital energy reserves needed for survival. Fireworks have even frightened birds into flying so far out to sea that they did not have the energy to make the return flight. Wild birds frightened by the noise of fireworks will also fly higher and for longer, which exposes them to the harmful cocktail of ingredients in fireworks like ozone, sulfur dioxide and nitric oxide that have caused cardiovascular and respiratory damage, and even death, in humans.

Casings and heavy metals that are littered by fireworks are often mistakenly consumed by wildlife or even fed to their young. Many of these materials are either indigestible and therefore choking hazards, or toxic to the animal, and pollutants from fireworks can be washed into waterways and contaminate drinking water for the animals that rely on it. And in regions of the country prone to wildfires, the slightest ember from a fireworks display can start a blaze that kills many wildlife species and destroys their habitats.

Humans, the residents in the area will be faced with loud fireworks in the evenings affecting family time. Try putting children to bed with the loud banging coming from the stadium.

<https://www.humanesociety.org/resources/fireworks-explosion-fear-animals>

### EFFECT ON THE ENVIRONMENT

Nitrogen and sulfur, used to create color and special effects, can combine with oxygen to form nitric and sulfuric acids which are very hard on the lungs. The smoke from the displays generally dissipates within a few hours, but individuals may feel lingering health effects.

What toxins are released by fireworks?

A case study found that within 1 hour of fireworks displays, strontium levels in the air increased 120 times, magnesium 22 times, barium 12 times, potassium 11 times, and copper (Cu) 6 times more than the amount already present in the air before the event (ref). Dec 31, 2019

What environmental damage is caused by fireworks?



Additionally, to produce the oxygen needed for an explosion, many fireworks contain oxidisers known as perchlorates. These can dissolve in water, contaminating rivers, lakes and drinking water. Finally, fireworks release a fine cloud of smoke and particulate matter, affecting local air quality.

Has your committee thought about the “impact” of the artificial lighting on the animals and residents?

#### EFFECT ON RESIDENTS

The use of artificial light at night-time has been linked to increased risk of sleep disorders, obesity, depression, metabolic disorders, and even breast cancer. Humans have evolved to develop a circadian rhythm of being awake during the day and asleep at night.

Children need quiet, good night sleep to grow.

#### EFFECT ON WILDLIFE AND ENVIRONMENT

Artificial light has several general effects on wildlife: Attracts some organisms (moths, frogs, sea turtles), resulting in them not being where they should be, concentrating them as a food source to be preyed upon, or just resulting in a trap which exhausts and kills them.

The effects of night lighting on wildlife have been known for hundreds, even thousands, of years. Hunters and fishers have used torches, lamps, and other light sources to attract their quarry to them, so powerful is the effect of light on some species. Gas-lit lighthouses have long had the reputation of attracting marine birds by the thousands, as well. But only in the past century, with the advent and spread of electricity, has the problem of artificial night lighting become so pervasive.

All animals and plants on this planet (including humans) are genetically adapted to regular day/night/seasonal cycles that have, in many places on the planet, been completely interrupted by the glow created by artificial lights. Although some animals may capitalize on the lighting, many suffer its effects, and one hundred years is not enough time to genetically adapt to these changes.

Artificial light has several general effects on wildlife:

Attracts some organisms (moths, frogs, sea turtles), resulting in them not being where they should be, concentrating them as a food source to be preyed upon, or just resulting in a trap which exhausts and kills them.

Repels some organisms, excluding them from habitat where they might otherwise make a living. Makes it a form of habitat loss.

Alters the day/night patterns, resulting in not getting enough sleep, not having enough down time for the body to repair itself, alters reproductive cycles.

Humans can go inside and turn out the lights to prevent these issues, but the frogs in the pond by the streetlamp can't. For animals that are very site specific, it's not an option to move. They just get eaten, or fail to reproduce. For those that can move, as more and more lighting encroaches on dark areas, the areas that are dark enough to move TO become fewer and further between. Artificial lighting is another form of habitat loss.

<https://myfwc.com/conservation/you-serve/lighting/pollution/>

## Bolivar, Silvia A.

---

**From:** anvanews@aol.com  
**Sent:** Thursday, February 29, 2024 12:04 PM  
**To:** t-marie-v@hotmail.com; fishman@consensusplanning.com; hdhauser@comcast.net; phcrumpsf@gmail.com  
**Cc:** Johnson@consensusplanning.com; brookemjordy@gmail.com; staylor@taylortowers.com; alamedamontoya@gmail.com; christinebnvdz@aol.com; emyers\_11@yahoo.com; stemax1@aol.com; grumpyeh46@comcast.net; boyznbari@msn.com; szuschlag58@gmail.com; Bolivar, Silvia A.; wbenson@bernco.gov; peggynorton@yahoo.com; mgriffiee@noreste.org; sec.dist4@gmail.com; edueweke@juno.com; kbbh@hotmail.com; ggarcia103@comcast.net; gypsy.rose46@gmail.com; haederle@yahoo.com  
**Subject:** Re: Meeting Notification - Balloon Fiesta Park / NM United Stadium

[EXTERNAL] Forward to [phishing@cabq.gov](mailto:phishing@cabq.gov) and delete if an email causes any concern.

Good afternoon,

I am in 100% Agreement with Pat Houser and Tina Villegas who stated the proposed meeting is rushed and does not allow for adequate notification or preparation. The points raised below are valid and should be considered.

The meeting should be held when there is adequate time for all to respond and make plans for a productive meeting. Set the meeting at least week into the future as was suggested by others.

We were only able to access the sent emails this morning - 2-29-2024. ANVA was never asked about what times would work best for the a meeting.

The arrogant and presumptuous announcements of the meeting times set by Consensus Planning is wrong. Setting the meeting for Monday is as we say in the north valley: complete and utter BS!

This illustrates why people were left out of the notification processes and why people have so many questions, fears and anger about the proposal. It is very apparent the agents for the City and United Soccer don't care about any type of real communication or collaboration with the community. This is wrong and the City of Albuquerque, United Soccer and their paid agents should be ashamed of their attitudes and arrogant actions.

Steve Wentworth  
Pres. Alameda North Valley Association

In a message dated 2/29/2024 8:04:47 AM Mountain Standard Time, t-marie-v@hotmail.com writes:

Good Morning,

I agree with Mr. Hauser that the notification of this meeting feels rushed and does not allow enough time for persons to be notified adequately as per the IDO. Also, since this is the only meeting that is scheduled if persons are unable to attend due to the short notice will another be scheduled prior to the EPC hearing on 3/21? I feel it is necessary to inform as many affected property owners so they have a chance to understand the full effect a new stadium will have on their neighborhood, be able to participate, and be able to give their feedback as allowed by this process.

I also think the meeting should allow for participation in person, via electronic, and by telephone because some may not have the means to attend electronically or by phone.

I respectfully request you consider Mr. Hauser's request.

Thank you.

**-Tina M. Villegas**  
**10212 Edith Blvd NE**  
**Albuquerque, NM 87113**  
**505-269-4652**

---

**From:** Jackie Fishman <fishman@consensusplanning.com>

**Sent:** Thursday, February 29, 2024 5:20 AM

**To:** Pat Hauser <hdhauser@comcast.net>; [mgriffie@noreste.org](mailto:mgriffie@noreste.org) <mgriffie@noreste.org>; [sec.dist4@gmail.com](mailto:sec.dist4@gmail.com) <sec.dist4@gmail.com>; [edueweke@juno.com](mailto:edueweke@juno.com) <edueweke@juno.com>; [kbbh@hotmail.com](mailto:kbbh@hotmail.com) <kbbh@hotmail.com>; [ggarcia103@comcast.net](mailto:ggarcia103@comcast.net) <ggarcia103@comcast.net>; 'Maggie Rose' <gypsy.rose46@gmail.com>; [anvanews@aol.com](mailto:anvanews@aol.com) <anvanews@aol.com>; 'Michael Haederle' <haederle@yahoo.com>

**Cc:** Charlene Johnson <Johnson@consensusplanning.com>; [brookemjordy@gmail.com](mailto:brookemjordy@gmail.com) <brookemjordy@gmail.com>; [staylor@taylortowers.com](mailto:staylor@taylortowers.com) <staylor@taylortowers.com>; [alamedamontoya@gmail.com](mailto:alamedamontoya@gmail.com) <alamedamontoya@gmail.com>; [christinebnvdz@aol.com](mailto:christinebnvdz@aol.com) <christinebnvdz@aol.com>; 'Tina Villegas' <t-marie-v@hotmail.com>; [emyers\\_11@yahoo.com](mailto:emyers_11@yahoo.com) <emyers\_11@yahoo.com>; [stemax1@aol.com](mailto:stemax1@aol.com) <stemax1@aol.com>; [grumpyeh46@comcast.net](mailto:grumpyeh46@comcast.net) <grumpyeh46@comcast.net>; 'BARI Harvey' <boyznbari@msn.com>; 'Sandy Z' <szuschlag58@gmail.com>; 'Bolivar, Silvia A.' <sabolivar@cabq.gov>; [wbenenson@bernco.gov](mailto:wbenenson@bernco.gov) <wbenenson@bernco.gov>; Peggy Norton <peggynorton@yahoo.com>; Steve Wentworth <anvanews@aol.com>

**Subject:** Re: Meeting Notification - Balloon Fiesta Park / NM United Stadium

Pat - please call me at 8:00 at my office number to discuss. As the primary appellant, I originally called you specifically on Tuesday and then got a call back from Brooke yesterday, who she said you asked to call me back. She and I discussed the date and we agreed Monday was acceptable.

Talk to you soon.

Jackie Fishman, AICP  
Principal

---

**From:** Pat Hauser <hdhauser@comcast.net>

**Sent:** Wednesday, February 28, 2024 9:42 PM

**To:** Jackie Fishman <fishman@consensusplanning.com>; [mgriffie@noreste.org](mailto:mgriffie@noreste.org) <mgriffie@noreste.org>; [sec.dist4@gmail.com](mailto:sec.dist4@gmail.com) <sec.dist4@gmail.com>; [edueweke@juno.com](mailto:edueweke@juno.com) <edueweke@juno.com>; [kbbh@hotmail.com](mailto:kbbh@hotmail.com) <kbbh@hotmail.com>; [ggarcia103@comcast.net](mailto:ggarcia103@comcast.net) <ggarcia103@comcast.net>; 'Maggie Rose' <gypsy.rose46@gmail.com>; [anvanews@aol.com](mailto:anvanews@aol.com) <anvanews@aol.com>; 'Michael Haederle' <haederle@yahoo.com>; Pat Hauser <hdhauser@comcast.net>

**Cc:** Charlene Johnson <Johnson@consensusplanning.com>; [brookemjordy@gmail.com](mailto:brookemjordy@gmail.com) <brookemjordy@gmail.com>; [staylor@taylortowers.com](mailto:staylor@taylortowers.com) <staylor@taylortowers.com>; [alamedamontoya@gmail.com](mailto:alamedamontoya@gmail.com) <alamedamontoya@gmail.com>; [christinebnvdz@aol.com](mailto:christinebnvdz@aol.com) <christinebnvdz@aol.com>; 'Tina Villegas' <t-marie-v@hotmail.com>; [emyers\\_11@yahoo.com](mailto:emyers_11@yahoo.com) <emyers\_11@yahoo.com>; [stemax1@aol.com](mailto:stemax1@aol.com) <stemax1@aol.com>; [grumpyeh46@comcast.net](mailto:grumpyeh46@comcast.net) <grumpyeh46@comcast.net>; 'BARI Harvey' <boyznbari@msn.com>; 'Sandy Z' <szuschlag58@gmail.com>; 'Bolivar, Silvia A.' <sabolivar@cabq.gov>; [wbenenson@bernco.gov](mailto:wbenenson@bernco.gov) <wbenenson@bernco.gov>; Peggy Norton <peggynorton@yahoo.com>; Steve Wentworth <anvanews@aol.com>

**Subject:** RE: Meeting Notification - Balloon Fiesta Park / NM United Stadium

Good morning Ms. Fishman: For the record this would seem as if there is another RUSH and PUSH to get this meeting completed due to the short notice and timeframes just to get a box checked.

It would seem problematic to me and others that this process may leave many concerned and interested people and property owners inappropriate time to plan for such a meeting.

I believe that giving less than 3 business days' notice regarding a public facilitated meeting about the City of Albuquerque Land Use APPEAL NO.AC-23-22 is problematic and may not comply with appropriate notice for such a complex and long-lasting impact on the future of multiple property owners.

This should be held in an appropriate location such as the City Council chambers or the County Chambers as a neutral location. There is possible issue with some individuals not having access to the internet or personal commitments that may have been arranged prior to this short-rushed agenda meeting process.

In the past notification for an EPC meeting allows interested parties appropriate and ample time for planning and preparation. This does none of that.

It is also problematic that comments have been limited in time of 2 minutes. This issue being so complex needs a much better communication process regarding the Neighborhood Associations and the affected property owners.

Based on previous meetings and communication input from non-proximity parties is inconsequential as it relates to the direct and forever impact on, we nearby residents. It is basically in our backyards.

My suggestion and recommendation are to have the meeting scheduled on a weekend such as March 9, 2023 allowing proper planning for all affected parties.

Thus, allowing for PEOPLE, PROCESS, AND PROCEDURES to be sensitive to the issues and challenges at hand.

It would also seem appropriate to have the entire City of Albuquerque Balloon Fiesta Park Master Development Plan rewritten vs the current select editing for one specific request as outlined in your communication.

Awaiting a positive response regarding the critical need to reschedule this communication process.

Regards: Pat Hauser

---

**From:** Jackie Fishman <fishman@consensusplanning.com>

**Sent:** Wednesday, February 28, 2024 7:22 PM

**To:** mgriffie@noreste.org; sec.dist4@gmail.com; edueweke@juno.com; kbbh@hotmail.com; ggarcia103@comcast.net; Maggie Rose <gypsy.rose46@gmail.com>; hdhauser@comcast.net; anvanews@aol.com; Michael Haederle <haederle@yahoo.com>

**Cc:** Charlene Johnson <Johnson@consensusplanning.com>; 'brookemjordy@gmail.com' <brookemjordy@gmail.com>; 'staylor@taylortowers.com' <staylor@taylortowers.com>; alamedamontoya@gmail.com; christinebnvdz@aol.com; Tina Villegas <t-marie-v@hotmail.com>; emyers\_11@yahoo.com; 'stemax1@aol.com' <stemax1@aol.com>; grumpyeh46@comcast.net; BARI Harvey <boyznbari@msn.com>; Sandy Z ([szuschlag58@gmail.com](mailto:szuschlag58@gmail.com)) <szuschlag58@gmail.com>; Bolivar, Silvia A. <sabolivar@cabq.gov>

**Subject:** Meeting Notification - Balloon Fiesta Park / NM United Stadium

Dear Neighbors:

The purpose of this email is to provide notification that the Balloon Fiesta Park Development Plan/Site Plan for Subdivision and Site Plan-EPC for a United New Mexico Soccer Stadium was remanded to the Environmental Planning Commission (EPC) by the Land Use Hearing Officer (LUHO) following an appeal by adjacent neighborhood associations. As part of the remand, the City of Albuquerque is inviting neighborhood associations and neighbors to a facilitated meeting to discuss the request.

The facilitated meeting will be held on **Monday, March 4, 2024, from 5:30 to 7:30 pm**. Representatives from the City of Albuquerque and New Mexico United will be in attendance to answer any questions and listen to community input. The meeting will be facilitated by a City contractor and held online via Google Meet using the link below.

[meet.google.com/xec-uycp-xea](https://meet.google.com/xec-uycp-xea)

Join by phone +1 414-909-3864, PIN 106965974

The EPC hearing will be held on **Thursday March 21, 2024, starting at 8:40 am**. The public is invited to attend the hearing and provide input regarding this project, which will be held via Zoom using the link below:

<https://cabq.zoom.us/j/2269592859> or by calling the following number: 1 301 715 8592 and entering Meeting ID: 226 959 2859

If you have any questions or concerns, please do not hesitate to contact myself at [fishman@consensusplanning.com](mailto:fishman@consensusplanning.com) or you may also contact the City of Albuquerque Planning Department at [devhelp@cabq.gov](mailto:devhelp@cabq.gov).

Sincerely,

**Jacqueline Fishman, AICP**

Principal

Consensus Planning, Inc.

302 Eighth Street NW

Albuquerque, NM 87102

P: 505.764.9801

**From:** [Tom Kennedy](#)  
**To:** [Bolivar, Silvia A.](#)  
**Cc:** [brookemjordy@gmail.com](mailto:brookemjordy@gmail.com)  
**Subject:** United Stadium at Balloon Fiesta Park  
**Date:** Sunday, March 10, 2024 1:48:03 PM

---

[EXTERNAL] Forward to [phishing@cabq.gov](mailto:phishing@cabq.gov) and delete if an email causes any concern.

Ms. Bolivar and Ms. Jordy:

I am writing concerning the proposed soccer stadium for United located at the Balloon Fiesta Park. As you have heard, this process of getting this stadium built by our Mayor is a catastrophe. I have lived in the Wildflower subdivision for 32 years. It is a great area. There are so many issues with this new stadium that need to be addressed and that is why the EPC needs to give us more time to properly prepare.

In our subdivision during the Balloon Fiesta, we deal with traffic speeding through our streets, people moving the barricades and parking, I truly believe this will be an issue with the new Stadium. United claims to be able to protect our neighborhood. My question is how? Albuquerque cannot afford to pull police officers off the streets to babysit our area. So how will they handle this?? No matter what they do, there will be those who choose not to pay for parking and try to park elsewhere, i.e. our neighborhood.

My next concern is what will this do to our wonderful balloon fiesta eventually. I honestly believe this will be their demise. The fiesta is a loved event and I can live with a little inconvenience during those 10 days. What this area cannot deal with is the noise and light and traffic issues building this stadium will cause.

This neighborhood was never properly notified of the project nor does the lease address any of the issues. Many people to the west of us will really suffer. They are rural and animals are prevalent. The noise will be horrible for them. We all know this and it will affect so many things. Our area does not need another noisy disruptive entertainment center. Also, what other events will be held at this stadium? Alameda is a mess on a good day let alone when events are happening.

Our Mayor could not get this passed by the people of Albuquerque to build a stadium, so he tried another way. There has to be a better location that will not interfere with the neighborhoods and the possible ruination of the Balloon Fiesta.

The EPC needs to relay the hearing until April.

Thank you  
Thomas Kennedy and Denise McCoy  
5024 Watercress Dr NE  
87113

If we all truly believe as taxpayers we will not be paying for this stadium, we are sadly mistaken.

## Bolivar, Silvia A.

---

**From:** Tina Villegas <t-marie-v@hotmail.com>  
**Sent:** Thursday, February 29, 2024 8:05 AM  
**To:** Jackie Fishman; Pat Hauser  
**Cc:** Charlene Johnson; brookemjordy@gmail.com; staylor@taylortowers.com; alamedamontoya@gmail.com; christinebnvdz@aol.com; emyers\_11@yahoo.com; stemax1@aol.com; grumpyeh46@comcast.net; 'BARI Harvey'; 'Sandy Z'; Bolivar, Silvia A.; wbenson@bernco.gov; Peggy Norton; mgriffee@noreste.org; sec.dist4@gmail.com; edueweke@juno.com; kbbh@hotmail.com; ggarcia103@comcast.net; 'Maggie Rose'; anvanews@aol.com; 'Michael Haederle'  
**Subject:** Re: Meeting Notification - Balloon Fiesta Park / NM United Stadium

[EXTERNAL] Forward to [phishing@cabq.gov](mailto:phishing@cabq.gov) and delete if an email causes any concern.

Good Morning,

I agree with Mr. Hauser that the notification of this meeting feels rushed and does not allow enough time for persons to be notified adequately as per the IDO. Also, since this is the only meeting that is scheduled if persons are unable to attend due to the short notice will another be scheduled prior to the EPC hearing on 3/21? I feel it is necessary to inform as many affected property owners so they have a chance to understand the full effect a new stadium will have on their neighborhood, be able to participate, and be able to give their feedback as allowed by this process.

I also think the meeting should allow for participation in person, via electronic, and by telephone because some may not have the means to attend electronically or by phone.

I respectfully request you consider Mr. Hauser's request.

Thank you.

*-Tina M. Villegas  
10212 Edith Blvd NE  
Albuquerque, NM 87113  
505-269-4652*

---

**From:** Jackie Fishman <fishman@consensusplanning.com>  
**Sent:** Thursday, February 29, 2024 5:20 AM  
**To:** Pat Hauser <hdhauser@comcast.net>; mgriffee@noreste.org <mgriffee@noreste.org>; sec.dist4@gmail.com <sec.dist4@gmail.com>; edueweke@juno.com <edueweke@juno.com>; kbbh@hotmail.com <kbbh@hotmail.com>; ggarcia103@comcast.net <ggarcia103@comcast.net>; 'Maggie Rose' <gypsy.rose46@gmail.com>; anvanews@aol.com <anvanews@aol.com>; 'Michael Haederle' <haederle@yahoo.com>  
**Cc:** Charlene Johnson <Johnson@consensusplanning.com>; brookemjordy@gmail.com <brookemjordy@gmail.com>; staylor@taylortowers.com <staylor@taylortowers.com>; alamedamontoya@gmail.com <alamedamontoya@gmail.com>; christinebnvdz@aol.com <christinebnvdz@aol.com>; 'Tina Villegas' <t-marie-v@hotmail.com>; emyers\_11@yahoo.com <emyers\_11@yahoo.com>; stemax1@aol.com <stemax1@aol.com>; grumpyeh46@comcast.net <grumpyeh46@comcast.net>; 'BARI Harvey' <boyznbari@msn.com>; 'Sandy Z' <szuschlag58@gmail.com>; 'Bolivar, Silvia A.' <sabolivar@cabq.gov>; wbenson@bernco.gov <wbenson@bernco.gov>; Peggy Norton <peggynorton@yahoo.com>; Steve Wentworth <anvanews@aol.com>  
**Subject:** Re: Meeting Notification - Balloon Fiesta Park / NM United Stadium



Pat - please call me at 8:00 at my office number to discuss. As the primary appellant, I originally called you specifically on Tuesday and then got a call back from Brooke yesterday, who she said you asked to call me back. She and I discussed the date and we agreed Monday was acceptable.

Talk to you soon.

Jackie Fishman, AICP  
Principal

---

**From:** Pat Hauser <hdhauser@comcast.net>

**Sent:** Wednesday, February 28, 2024 9:42 PM

**To:** Jackie Fishman <fishman@consensusplanning.com>; mgriffie@noreste.org <mgriffie@noreste.org>; sec.dist4@gmail.com <sec.dist4@gmail.com>; edueweke@juno.com <edueweke@juno.com>; kbbh@hotmail.com <kbbh@hotmail.com>; ggarcia103@comcast.net <ggarcia103@comcast.net>; 'Maggie Rose' <gypsy.rose46@gmail.com>; anvanews@aol.com <anvanews@aol.com>; 'Michael Haederle' <haederle@yahoo.com>; Pat Hauser <hdhauser@comcast.net>

**Cc:** Charlene Johnson <Johnson@consensusplanning.com>; brookemjordy@gmail.com <brookemjordy@gmail.com>; staylor@taylortowers.com <staylor@taylortowers.com>; alamedamontoya@gmail.com <alamedamontoya@gmail.com>; christinebnvdz@aol.com <christinebnvdz@aol.com>; 'Tina Villegas' <t-marie-v@hotmail.com>; emyers\_11@yahoo.com <emyers\_11@yahoo.com>; stemax1@aol.com <stemax1@aol.com>; grumpyeh46@comcast.net <grumpyeh46@comcast.net>; 'BARI Harvey' <boyznbari@msn.com>; 'Sandy Z' <szuslag58@gmail.com>; 'Bolivar, Silvia A.' <sabolivar@cabq.gov>; wbenson@bernco.gov <wbenson@bernco.gov>; Peggy Norton <peggynorton@yahoo.com>; Steve Wentworth <anvanews@aol.com>

**Subject:** RE: Meeting Notification - Balloon Fiesta Park / NM United Stadium

Good morning Ms. Fishman: For the record this would seem as if there is another RUSH and PUSH to get this meeting completed due to the short notice and timeframes just to get a box checked.

It would seem problematic to me and others that this process may leave many concerned and interested people and property owners in appropriate time to plan for such a meeting.

I believe that giving less than 3 business days' notice regarding a public facilitated meeting about the City of Albuquerque Land Use APPEAL NO.AC-23-22 is problematic and may not comply with appropriate notice for such a complex and long-lasting impact on the future of multiple property owners.

This should be held in an appropriate location such as the City Council chambers or the County Chambers as a neutral location. There is possible issue with some individuals not having access to the internet or personal commitments that may have been arranged prior to this short-rushed agenda meeting process.

In the past notification for an EPC meeting allows interested parties appropriate and ample time for planning and preparation. This does none of that.

It is also problematic that comments have been limited in time of 2 minutes. This issue being so complex needs a much better communication process regarding the Neighborhood Associations and the affected property owners.

Based on previous meetings and communication input from non-proximity parties is inconsequential as it relates to the direct and forever impact on, we nearby residents. It is basically in our backyards.

My suggestion and recommendation are to have the meeting scheduled on a weekend such as March 9, 2023 allowing proper planning for all affected parties.

Thus, allowing for PEOPLE, PROCESS, AND PROCEDURES to be sensitive to the issues and challenges at hand.

It would also seem appropriate to have the entire City of Albuquerque Balloon Fiesta Park Master Development Plan rewritten vs the current select editing for one specific request as outlined in your communication.

Awaiting a positive response regarding the critical need to reschedule this communication process.

Regards: Pat Hauser

**From:** Jackie Fishman <fishman@consensusplanning.com>

**Sent:** Wednesday, February 28, 2024 7:22 PM

**To:** mgriffee@noreste.org; sec.dist4@gmail.com; edueweke@juno.com; kbbh@hotmail.com; ggarcia103@comcast.net; Maggie Rose <gypsy.rose46@gmail.com>; hdhauser@comcast.net; anvanews@aol.com; Michael Haederle <haederle@yahoo.com>

**Cc:** Charlene Johnson <Johnson@consensusplanning.com>; 'brookemjordy@gmail.com' <brookemjordy@gmail.com>; 'staylor@taylortowers.com' <staylor@taylortowers.com>; alamedamontoya@gmail.com; christinebnvdz@aol.com; Tina Villegas <t-marie-v@hotmail.com>; emyers\_11@yahoo.com; 'stemax1@aol.com' <stemax1@aol.com>; grumpyeh46@comcast.net; BARI Harvey <boyznbari@msn.com>; Sandy Z (szuschlag58@gmail.com) <szuschlag58@gmail.com>; Bolivar, Silvia A. <sabolivar@cabq.gov>

**Subject:** Meeting Notification - Balloon Fiesta Park / NM United Stadium

Ghdu#hjkewr=

#

Wkh#sxusrvh#r#k#l#p d#l#v#r#surygh#q#r#w#l#f#d#w#r#k#d#w#k#h#E#d#o#r#r#q#l#h#w#d#s#d#u#G#h#y#h#o#s#p#h#q#w#S#o#q#2#l#h#S#o#q#r#u#  
V#x#e#g#l#v#l#r#q#d#g#g#v#l#h#S#o#q#H#S#F#r#u#d#k#q#l#h#g#Q#h#z#P#h#{#f#r#v#r#f#h#u#v#d#g#k#p#z#d#v#h#p#d#g#g#h#r#k#h#H#q#y#l#r#q#p#h#q#w#d#S#o#q#q#l#j#  
F#r#p#p#l#v#l#r#q#H#S#F#,#e|#k#h#D#d#g#g#K#v#h#K#h#d#u#l#j#R#i#l#f#h#u#O#X#K#R#,#r#o#r#z#l#j#d#q#d#s#s#h#d#e|#d#g#n#f#h#q#w#q#h#l#j#k#e#r#k#r#r#g#  
d#v#r#f#l#b#w#r#q#v#D#v#s#d#u#r#k#h#h#p#d#g#g#k#h#F#l#l#r#d#e#x#t#x#h#u#t#x#h#v#l#q#y#l#q#j#h#l#j#k#e#r#k#r#r#g#d#v#r#f#l#b#w#r#q#v#d#g#g#q#h#l#j#k#e#r#w#r#d#h#  
i#d#f#l#d#w#g#p#h#h#w#l#q#j#r#r#g#l#f#x#v#w#k#h#h#t#x#h#w#l

#

Wkh#i#d#f#l#d#w#g#p#h#h#w#l#q#j#z#l#e#h#k#h#g#r#q#P#r#q#g#d|#P#d#u#f#k#5#4#5#3#5#7#/#w#d#w#l#q#j#d#w#=#7#3#d#p#W#k#h#s#e#d#f#h#v#q#y#l#h#g#r#d#w#h#g#g#k#h#  
r#d#e#x#t#x#h#u#t#x#h#d#g#g#Q#h#z#P#h#{#f#r#k#q#l#h#g#z#l#e#h#k#h#g#d#w#h#g#g#d#q#f#h#r#d#q#v#h#u#d#q|#x#h#w#l#r#q#v#d#g#g#l#v#h#q#r#F#r#p#x#q#l|#q#s#w#  
W#k#h#p#h#h#w#l#q#j#z#l#e#h#i#d#f#l#d#w#g#e|#d#F#l#l#r#q#w#d#f#w#r#d#g#g#k#h#g#r#q#d#h#y#d#r#r#j#d#P#h#h#w#k#v#l#q#j#k#h#d#q#n#e#h#o#r#z#l

#

p hhwjrrj d l frp 2 {hf0x | fs0{hd  
Mr l q e | #k r q h # . 4 # 7 4 7 0 < 3 < 0 6 ; 9 7 # 5 I Q # l 3 9 < 9 8 < : 7

#

Wkh#H#S#F#k#h#d#u#l#j#z#l#e#h#k#h#g#r#q#W#k#x#u#v#g#d|#P#d#u#f#k#5#4#5#3#5#7#/#w#d#w#l#q#j#d#w#=#7#3#d#p#W#k#h#s#e#d#f#h#v#q#y#l#h#g#r#d#w#h#g#g#k#h#  
k#h#d#u#l#j#d#g#g#s#u#r#y#g#h#g#q#s#w#h#j#d#u#l#j#j#k#l#v#s#u#r#n#f#w#z#k#l#f#k#z#l#e#h#k#h#g#y#d#h#r#r#p#k#v#l#q#j#k#h#d#q#n#e#h#o#r#z#l#

#

[kwsv=2fdetjrrp kv2559<8<5;8<#r#e|#f#d#o#l#j#k#h#r#o#r#z#l#j#q#x#p#e#h#u#l#5#3#4#:#4#8#;8<5#d#g#g#h#q#w#h#u#l#j#P#h#h#w#l#q#j#  
IG#559#8<#5;8<](#)

#

I#h#r#x#k#d#y#h#d#q|#x#h#w#l#r#q#v#r#u#f#r#q#f#h#u#v#/#s#d#v#h#r#r#g#r#w#h#v#l#d#w#r#F#r#q#w#d#f#w#p|#h#o#d#w#[l#k#p#d#g#C#f#r#q#v#h#q#v#x#v#s#o#q#q#l#j#l#f#r#p#](#)  
r#u#r#x#p#d|#d#o#r#F#r#q#w#d#f#w#k#h#F#l#l#r#d#e#x#t#x#h#u#t#x#h#S#o#q#q#l#j#G#h#s#d#u#p#h#q#w#d#w#[p#h#y#k#h#o#C#f#d#e#t#l#j#r#y#l](#)

#

V l q f h u h q /

Mift x h d q h # l # k # p # d # g # / # D # I # F # S  
S u b j f l s d o  
F r q v h q v x v # S o l q q l j # / # q # f # l  
6 3 5 # I l j k w k # / v # h # h # Q # Z  
D e x t x h u t x h # / # Q # P # ; : 4 3 5  
S # 3 3 8 1 : 9 7 k ; 3 4

**Bolivar, Silvia A.**

---

**From:** Tina Villegas <t-marie-v@hotmail.com>  
**Sent:** Monday, March 11, 2024 12:05 AM  
**To:** Bolivar, Silvia A.  
**Subject:** 3/21 EPC Hearing Comments - Proposed Stadium at Balloon Fiesta Park  
**Attachments:** 3-21-2024 EPC Hearing Comments - TVillegas.docx

[EXTERNAL] Forward to [phishing@cabq.gov](mailto:phishing@cabq.gov) and delete if an email causes any concern.

Good evening,

Attached please find my letter for the EPC hearing, to be included in the record.

Please acknowledge receipt of this email.

Thank you.

*Tina M. Villegas*

10212 Edith Blvd. NE  
Albuquerque, NM 87113  
505-269-4652

March 10, 2024

**VIA ELECTRONIC MAIL**

Environmental Planning Commission  
City of Albuquerque  
c/o Silvia Bolivar  
[sabolivar@cabq.gov](mailto:sabolivar@cabq.gov)

Subject: Written Comments for the March 21, 2024, EPC Hearing – Proposed Stadium at Balloon Fiesta Park

Dear Ms. Bolivar:

My name is Tina Villegas and I live at 10212 Edith Blvd. NE, Albuquerque, NM 87113, and I am a resident of the North Edith Corridor neighborhood in unincorporated Bernalillo County. I am wholeheartedly opposed to amending the Master Development Plan (MDP) at Balloon Fiesta Park (BFP) that would permit construction of a multi-use stadium at the park.

I have lived in the North Edith Corridor for almost 19 years and my home is only 2,059 feet from the west side of the proposed new stadium. I am most concerned about the noise pollution from the new stadium since New Mexico United (United) is unable to tell us what other events besides soccer will be held at the stadium. Although United has indicated they have improved the stadium design to mitigate noise traveling down to the neighborhoods located to the west, I do not believe they will be able to contain any of the noise unless they put a roof on the stadium. All noise travels down to the lower neighborhoods because I hear most of the events that happen at Balloon Fiesta Park, from the kids practicing soccer, the drones and model airplanes flying around the park, to the larger events such as the Wine Festival, and Freedom 4<sup>th</sup>, to the long 9-days of the Albuquerque International Balloon Fiesta. The sound from the music events and the fireworks often vibrates the windows of my house during events like the Calvary Church Freedom Celebration and the Los Alamos Concert. I have tried contacting the City regarding issues with noise at BFP; however, most times nothing is done.

This is concerning because United keeps telling us that they want to work with the neighborhoods; however, I have only been invited to one meeting held by Consensus Planning and United back in November 2023. A second meeting was held with a mediator on 3/4/2024. At both meetings United could not provide the neighborhoods with much information regarding how they will contain the noise from a stadium of 7,000-10,000 people. Cheering fans with drums and loud sounding horns. Loud music being played to hype up the crowd, and even the possibility of fireworks. My dogs are

very afraid of the fireworks held during the Albuquerque International Balloon Fiesta and I do not wish for them to be further exposed to this type of noise during soccer games. Furthermore, I do not want to pick up the mess left by the firework debris that falls in my yard because I do not want my dogs to think they are chew toys. The local news media also indicates United usually has tailgating before all events that can even include bands playing loud music outside of the stadium. Even though United states their games are usually done by 9:00 p.m. my elderly mother-in-law is usually in bed by 7:00 p.m. so why should she be disturbed in her own home by the noise coming from the stadium? I live near several older neighbors who asked me to speak for them that they also do not want their quiet, rural neighborhood disturbed by events held at the stadium.

The stadium will not be in harmony with our neighborhoods which are rural, with small farms, livestock, migratory birds, rabbits, skunks, racoons, and coyotes. The Edith Corridor precedes BFP, and the MDP does not allow for a stadium in the first place.

United cannot accurately assess the impact the stadium will have on our neighborhoods in terms of noise. The team's architect said at a meeting with neighbors in March that sound on the field could reach ninety decibels which is more than the sound ordinance allows. Although United indicated they would do another sound study that will measure sound from the proposed stadium area to neighboring houses, that study will not be done until after the EPC has already decided this matter.

Without written assurances from United, how can the neighborhoods understand what types of events will be held at the stadium and how issues with sound will be resolved. United keeps saying they will work with the communities, but we already get that answer from the City which does not help us now, so how can we trust issues will even be investigated once the stadium is built.

United also cannot be sure that light from the stadium will not impact the houses located to the west and northwest. Although United indicates the main lights of the stadium will be positioned as such to project the light downward this may not be enough to keep the light from shining into my upstairs windows at night. What about other lighting outside of the stadium to light walkways and the parking areas? Because my house sits directly across from the proposed stadium, which is lower than BFP, light pollution could be a factor and once the stadium is built what would be my recourse?

United makes brief mention of a "Community Benefits Program" in the Lease but could not give specifics to the neighborhoods regarding the program when asked at the March 4, 2024, meeting.

There are several issues which United has not addressed properly regarding the proposed stadium. United keeps stating they will work with the neighborhoods; however, what if issues are not corrected then what recourse will the neighborhoods have once the stadium is built? The EPC is responsible for protecting the residents and property owners from issues such as this and I respectfully request you vote no to amend the MDP at BFP.

Thank you for your time and consideration.

Sincerely,

A handwritten signature in black ink that reads "Tina M. Villegas". The signature is written in a cursive style with a large, stylized initial 'T'.

***Tina M. Villegas***  
10212 Edith Blvd NE  
Albuquerque, NM 87113  
(505) 269-4652

**From:** [Annette Kitts](#)  
**To:** [Bolivar, Silvia A.](#); [Planning EPC](#)  
**Cc:** [Steve & Annette Kitts](#)  
**Subject:** Opposed to Stadium at Balloon Fiesta Park  
**Date:** Monday, March 11, 2024 5:04:34 PM

---

**[EXTERNAL]** Forward to [phishing@cabq.gov](mailto:phishing@cabq.gov) and delete if an email causes any concern.

I am opposed to this stadium being built at the Balloon Fiesta Park (BFP) for the reasons below:

- We live in this area for the rural lifestyle. Adding the stadium will add even more events than are held at the BFP.
- Adding more events at BFP will bring more pollution to our area which affects the livestock and community negatively.
- During the balloon fiesta we deal with fireworks, concerts, traffic, for 10 days and have coped with this for years but we know when and how long this will happen for.
- Currently there is no idea of how many or what type of events are going to be in addition to the soccer games.

This leaves the door open to so many other things that can affect our way of rural living.

Thank you for your consideration.

Annette Santiago-Kitts



**Bolivar, Silvia A.**

---

**From:** LuElena Gonzales <luelenagonzales@hotmail.com>  
**Sent:** Tuesday, March 19, 2024 7:42 AM  
**To:** Bolivar, Silvia A.  
**Subject:** Letter of Opposition regarding Balloon Fiesta Park Master Development Plan  
**Attachments:** Letter to City Council 3.19.24.pdf

[EXTERNAL] Forward to [phishing@cabq.gov](mailto:phishing@cabq.gov) and delete if an email causes any concern.

Dear Ms. Bolivar:

Attached please find a letter in opposition to the proposal to amend the Balloon Fiesta Park Master Development Plan to permit construction of a multi-use stadium, which is scheduled for consideration by the Environmental Planning Commission at its March 21 meeting.

Regards,  
LuElena Gonzales

March 19, 2024

To: Ms. Silvia A. Bolivar; Environmental Planning Commission

I am writing in opposition to the proposed amendment of the Master Development Plan at Balloon Fiesta Park to allow construction of a multi-use stadium at the park.

I am a life-long resident of Albuquerque. I currently reside in the Amara Vista Neighborhood, which is an 8-home gated subdivision along Edith, north of Alameda. My back yard backs up to the North Diversion Channel, basically making us backdoor neighbors with the Balloon Fiesta Park. This area is along the historic Camino Real; we chose to build a home in this area for its semi-rural character, not for its proximity to the Balloon Fiesta Park and the events held on the premises.

For ten days a year, the Albuquerque skies are filled with balloons. My family enjoys watching the balloons from our home as well as attending the Balloon Fiesta events in person. For ten days a year, we also hear amplified sounds from the speakers, which sometimes sound like we are standing in the middle of the field, when in fact, we are inside our home. During Balloon Fiesta fireworks shows, the walls and windows of my home shake. There have been times when debris from the City's Freedom Fourth fireworks show land in my yard/on my roof. My house is less than 8 years old, and we have many cracks on our stucco, likely from the walls shaking. While the noise and shaking can be cumbersome, we are thankful that the folks at the Albuquerque International Balloon Fiesta (AIBF) are committed to being good neighbors. Before and after each Fiesta, the higher-ups from AIBF meet with neighboring neighborhood associations to discuss concerns brought about by such a large event.

My biggest concern with the proposed soccer stadium being built at Balloon Fiesta Park is will United Soccer and the City follow suit with AIBF and be good neighbors? Will they adhere to noise/sound ordinances that are in place? I can attest that when other events that are of a smaller scale compared to the Balloon Fiesta are held at Balloon Fiesta Park (such as the wine festival), noise/sound ordinances are not enforced as we can hear what is happening from our home just as we would if we were there in person—and our walls and windows are rattling. No one is coming around to ask if we have concerns about events held at Balloon Fiesta Park. There isn't a number we can call to have sound levels measured and managed. Simply put, we are out of sight out of mind.

I feel that the City of Albuquerque's Integrated Development Ordinance (IDO) is, among other things, in place to "Provide reasonable protection from possible nuisances and hazards and to otherwise protect and improve public health". When my children cannot play outside because noise levels coming from the Balloon Fiesta Park are so loud that their ears hurt, the lack of monitoring and managing sound levels coming from non-Balloon Fiesta events is to blame. If the amplified sound is too loud for my children to play outside—and we live a little more than 2000 feet from the proposed location—how loud will the sound be inside the stadium?

Modifying the Master Development Plan at the Balloon Fiesta Park to allow the construction of a stadium will only increase the number of instances when my children—and others in this area—are negatively impacted. It would violate provisions of the IDO and allow the lack of monitoring and management of sound to continue to go unchecked.

Thank you for your consideration.

Regards,

LuElena Gonzales  
Amara Vista Neighborhood

**Bolivar, Silvia A.**

---

**From:** Brooke Jordy <brookemjordy@gmail.com>  
**Sent:** Wednesday, April 3, 2024 9:16 PM  
**To:** Bolivar, Silvia A.  
**Subject:** Comments for April 11th EPC Hearing on Stadium  
**Attachments:** 2024.4.11 EPC Hearing Comments - Brooke Jordy.docx.pdf

[EXTERNAL] Forward to [phishing@cabq.gov](mailto:phishing@cabq.gov) and delete if an email causes any concern.

Good evening, Ms. Bolivar,

Please find attached my written comments opposing a multi-use stadium being built in Balloon Fiesta Park. Also attached are the dozens of signatures of neighbors opposing the stadium (sent as a Google Drive link, since the file is so large). I request that all attachments be included in the formal record.

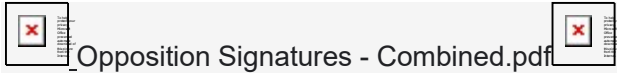

I want to note a few things for you:

1. Neighbors have yet to be informed how they will be permitted to cross examine opponents at the EPC hearing
2. Neighbors have yet to be informed of the format of the hearing (how much time, whether speakers can yield their time to others, etc.). We have requested this information many, many times.
3. Neighbors are requesting a 90-day deferral of the April 11th hearing.

All the best,

Brooke Jordy

April 3, 2024

Environmental Planning Commission  
City of Albuquerque  
c/o Silvia Bolivar  
sabolivar@cabq.gov

**Via Electronic Mail**

Re: *Written Comments for April 11, 2024 Hearing – Balloon Fiesta Park Stadium*

Dear Ms. Bolivar:

My name is Brooke Jordy. I live at 9629 Del Fuego Cir NE, Albuquerque, NM 87113 in the North Edith Corridor neighborhood. Our quiet, rustic neighborhood borders Balloon Fiesta Park. As an affected neighbor, my comments pertaining to the New Mexico United/City of Albuquerque proposal to erect a multi-use stadium in Balloon Fiesta Park are included herein for consideration by the EPC. I vehemently oppose the proposed amendment of the Master Development Plan at Balloon Fiesta Park to permit construction of a multi-use stadium at the park. I am including with this letter the signatures of **dozens** of neighbors from areas immediately surrounding the Park who also oppose building a stadium within Balloon Fiesta Park.

On February 16, 2024, a land use hearing officer granted the neighbors' appeal on due process violations made by Consensus Planning. Hearing Officer Chavez's order stated the appeal is to be done *de novo* and the next EPC hearing shall follow *State ex rel. Battershell v. City of Albuquerque*, 1989-NMCA-045. It has yet to be understood by Consensus Planning that this is a *de novo* appeal; as such, many individuals have yet to receive notice of the March 21st EPC hearing. **The neighbors/appellants request a 90-day deferral of this hearing.** Somehow, Consensus Planning and the City were able to coordinate a reset from March 21, 2024 to April 11, 2024. Neighbors were not asked for their position on rescheduling to this date. Many key speakers for the neighbors—myself included—are unavailable on April 11th. We have also heard through the grapevine that New Mexico United has allegedly made changes to their stadium plans. We have yet to see those changes, and need additional time to review the updated plans for any EPC hearing.

**BACKGROUND**

My husband and I purchased our home—our first—primarily for the location. Living in this part of the North Valley is reminiscent for both of us of growing up in Las Cruces (my husband) and Taos (myself). We chose to buy our first home here to start our family because it is a quiet, rustic area with generational homes. There is more wildlife, livestock, and migratory birds here than most of Albuquerque. Our neighbors use the acequias to water their hay fields, sheep, goats, apple trees, and more. At night, the neighborhood is quiet with little light and no street lights. We can see the stars. I have to check my yard to make sure skunks and racoons are gone before I let my dogs out at night.

Of course, we chose this location knowing the Balloon Fiesta would impact our lives about 9 days a year. However, being so well-established, the Balloon Fiesta employs contractors to monitor sound throughout the Fiesta. The Balloon Fiesta is better at adjusting amplified sound than the City is for other events held throughout the year. During the Fiesta, residents in surrounding areas are given

access permits and roadblocks are set up throughout neighborhoods to ensure there is little to no off-site parking on side streets. Of course, taxpayers cover the cost of law enforcement for these road closures and restrictions. However, for 9 days out of a year, it is tolerable.

There are fireworks 2-3 times per Fiesta. Luckily, my dogs are calm and just hide under the couch. For many others, however, this is their nightmare. More pets escape and run away during Fourth of July, for example, than any other night. Livestock are negatively impacted by fireworks, as are wildlife. The City sets off Fourth of July fireworks from the end of Edith. Many of my neighbors experience literal fallout from those fireworks—fireworks cartridges, gunpowder, and other detritus litter their properties. The air is full of smoke and remains hazy for hours. Veterans and others with PTSD suffer, as well. Fireworks pollute.<sup>1</sup>

### ENVIRONMENTAL IMPACTS

Building a stadium in this otherwise quiet, semi-rural area will introduce noise, light, water, and air pollution to our environment. New Mexico United sets off fireworks regularly. Their fans tailgate; they play drums, set off smoke bombs, yell, and blow vuvuzelas<sup>2</sup> throughout soccer matches. During each game, the team's fan club has a "noisy minute" where the stadium attendees make as much noise as possible.<sup>3</sup>

**Noise Pollution.** Amplified sound from a stadium would create relentless disruption and frustration both for neighbors, animals, and the environment. The Albuquerque Box, the unique weather pattern in our city that makes the Balloon Fiesta an international phenomenon, creates drainage winds that travel in an abnormal pattern.<sup>4</sup> Like the balloons that are carried from the Park to the west over our neighborhood, noise is also carried from the Park to the north and the west. Individuals in the Maria Diers neighborhood, for example, can hear non-amplified sound from the Park. Erecting a stadium in the Park will bring amplified and non-amplified noise to our quiet area. United has stated there will be numerous events at the stadium—concerts, private parties, women's soccer and men's soccer games, etc. However, there are no restrictions in the team's lease to limit events, noise levels, or noise monitoring requirements. Additionally, fireworks bring significant noise pollution to the area. Increasing soccer games and events at the Park will increase fireworks at the Park.

**Light Pollution.** A stadium, no matter how careful its architects are, necessarily brings light pollution. Headlights, parking lights, and stadium and field lights will pollute the relatively dark skies in this section of Albuquerque. Since the Park is situated at a higher elevation than neighborhoods west of the park, lights from the field and the Park shine down on hundreds, potentially thousands, of homes to the west. Even people in Rio Rancho and the Westside of Albuquerque report being

---

<sup>1</sup> Earth.org, *Crowd-Pleasing Fireworks Are Not So Pleasing to the Planet*, available at <https://earth.org/environmental-impact-of-fireworks/>.

<sup>2</sup> Discovery, *Annoying Vuvuzelas Explained*, available at <https://www.youtube.com/watch?v=X15iQFKyqgw>.

<sup>3</sup> KOAT.com, *History and Traditions of New Mexico United*, available at <https://www.koat.com/article/new-mexico-united-history-fan-culture-2024-season/60051431>.

<sup>4</sup> Weather.gov, *Balloon Fiesta Feature*, available at <https://www.weather.gov/media/abq/Briefings/BalloonFiestaFeatureNew.pdf>.

able to see the lights from the Park. Migratory birds from the Bosque will be negatively impacted by increased light pollution in the area.<sup>5</sup>

**Water Pollution.** Balloon Fiesta Park borders the North Diversion Channel, which carries Albuquerque’s stormwater runoff to the Rio Grande. There also exists a maze of acequias throughout the North Valley, which residents use to water their livestock and agriculture. Fallout from fireworks at the stadium will land in the acequias and the North Diversion Channel, poisoning so many throughout the Valley and downstream.

**Traffic & Emissions.** Increasing the frequency and volume of vehicles visiting Balloon Fiesta Park to attend stadium events will also bring problematic traffic and air pollution. Vehicle emissions are responsible for soot, smog, and carbon dioxide pollution.<sup>6</sup> In 2023, “Albuquerque was named one of the top 25 worst cities in the nation for ozone pollution.”<sup>7</sup> Building yet another stadium and event center, especially so close to the river and Diversion Channel, is unnecessary and threatens the environmental future of so many New Mexicans.

## VIOLATIONS OF IDO

Amending the Park’s Master Development Plan to allow a multi-use stadium to be built would violate core provisions of the City of Albuquerque’s Integrated Development Ordinance (IDO). The IDO is intended to “Protect the abundant natural resources that characterize Albuquerque, including but not limited to Major Public Open Space, Sensitive Lands, the Rio Grande, and the waterways that lead to the river.” Section 1-3(L). Locating a multi-use stadium at Balloon Fiesta Park poses significant negative impacts to adjacent “sensitive lands” due to the Park’s proximity to the Rio Grande and the North Diversion Channel. Increasing light and noise pollution in close proximity to migrating birds and other protected species that inhabit the Bosque will negatively impact those species. Further, the IDO is intended to “provide reasonable protection from possible nuisances and hazards and to otherwise protect and improve public health.” Section 1-3(N). The architect for the United stadium has stated on multiple occasions that the team intends to permit sustained levels of amplified sound at 90 decibels on the playing field.

## USE OF PUBLIC FUNDS

The State and City have pledged approximately \$25,000,000 in capital outlay funds to this project. While United and the City both claim taxpayer money is not being spent on the stadium build, Lawrence Rael made the reality clear at the November 16, 2023 City Council meeting. At that meeting, he was asked what the capital outlay funds would be used on if not this project. Mr. Rael responded that if a stadium is not built, the funds would not be spent to improve Balloon Fiesta Park.

---

<sup>5</sup> U.S. Fish & Wildlife Service, *Threats to Birds: Collisions – Nighttime Lighting*, available at <https://www.fws.gov/story/threats-birds-collisions-nighttime-lighting#:~:text=Why%20is%20this%20harmful%20to,colliding%20with%20buildings%20and%20infrastructure>; United Nations, *The Growing Effects of Light Pollution on Migratory Birds*, available at <https://www.un.org/en/un-chronicle/growing-effects-light-pollution-migratory-birds>.

<sup>6</sup> U.S. Environmental Planning Agency, *Smog, Soot, and Other Air Pollution from Transportation*, available at <https://www.epa.gov/transportation-air-pollution-and-climate-change/smog-soot-and-other-air-pollution-transportation>

<sup>7</sup> American Lung Association, Press Release, April 18, 2023, available at <https://www.lung.org/media/press-releases/nm-sota-23>.

## LEASE AGREEMENT

On November 16, 2023, the Albuquerque City Council approved an insufficient lease agreement with New Mexico United for their use of the stadium. This short, vague lease is nothing short of ridiculous. To permit a for-profit company to pay only \$35,000 per year for 7 acres of property is unheard of. The City's lack of concern for specific terms in the lease is problematic and will likely result in United taking advantage of the terms. I urge the EPC to consider the long-term impacts of approving a stadium build, including but not limited to the problems posed by such a vague lease benefitting a for-profit company.

## CONCLUSION

I strongly oppose approving the site plan to build a multi-use stadium within Balloon Fiesta Park. A stadium will bring noise, light, water, and air pollution to a semi-rural area. It will negatively impact wildlife and livestock in the area, including migrating birds. There is no way to un-ring the bell once this is done. This area already bears the brunt of Balloon Fiesta and the Fourth of July, along with hundreds of other events at the Park each year. I encourage the EPC to take this opportunity to ensure that the environmental future of Albuquerque, the North Edith Corridor, and surrounding neighborhoods are all protected.

Respectfully submitted,



---

Brooke Jordy

cell: 575-770-4389

brookemjordy@gmail.com



IN OPPOSITION TO LOCATING THE NEW MEXICO UNITED STADIUM AT BALLOON FIESTA PARK

We are opposed to the City of Albuquerque entering into an agreement with New Mexico United to locate a soccer stadium at Balloon Fiesta Park and are appealing the Albuquerque Environmental Planning Commission's November 16, 2023, decision to amend the park master development plan to allow a multi-use stadium.

We live, do business or own property in close proximity to the park and have serious concerns about noise, lighting and traffic. Based on our experience with activities already existing at the park, the addition of a 8,000- to 10,000-seat open arena hosting soccer games and other activities will further degrade our enjoyment of our property.

Michael Haederle

10312 Edith Blvd NE 87113

505-453-6072

[haederle@yahoo.com](mailto:haederle@yahoo.com)

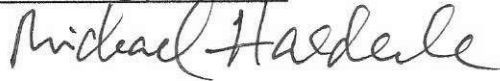

Leslie Linthicum

10312 Edith Blvd. NE 87113

505-306-6488

[leslielinthicum@gmail.com](mailto:leslielinthicum@gmail.com)



IN OPPOSITION TO LOCATING THE NEW MEXICO  
UNITED STADIUM AT BALLOON FIESTA PARK

We are opposed to the City of Albuquerque entering into an agreement with New Mexico United to locate a soccer stadium at Balloon Fiesta Park and are appealing the Albuquerque Environmental Planning Commission's November 16, 2023, decision to amend the park master development plan to allow a multi-use stadium.

We live, do business or own property in close proximity to the park and have serious concerns about noise, lighting and traffic. Based on our experience with activities already existing at the park, the addition of a 8,000- to 10,000-seat open arena hosting soccer games and other activities will further degrade our enjoyment of our property.

Name: Victoria Wilder  
Address: 5101 Watercross Dr NE 87113  
Email:  
Phone:

Name: Ronald Wilder  
Address: 5101 Watercross Dr NE 87113  
Email:  
Phone:

Name: Denise McCoy  
Address: 5024 Watercross NE 87113  
Email: denisemccoy73@gmail.com  
Phone: 505-239-4505

Name: Tom Kennedy  
Address: 5024 Watercross  
Email: TK37ford@gmail.com  
Phone: 505-232-250-0945

Name: Rosie Johnson  
Address: 5028 Blue Sage Pl. NE ABQ 87113  
Email: rosiej44@yahoo.com  
Phone: (505) 249-3162

Name: Zachary J Harvey (Zachary Harvey)  
Address: 5108 Watercross Dr NE 87113  
Email: zacattack10@live.com  
Phone: (505) 977-0851

Name: Roy Johnson  
Address: 5028 Blue Sage Pl. NE Albuquerque, NM 87113  
Email: royejohnson1971@gmail.com  
Phone: (505) ~~249~~-342-6720

Name: Courtney Johnson  
Address: 5028 Blue Sage Pl. NM 87113  
Email: cjohnson3427@gmail.com  
Phone: (505) 249-3274

Name: Amber Anderson  
Address: 5108 Golden Thread NE  
Email: anderson.amber@gmail.com  
Phone: (505) 250-9171

Name: Karen Boothe  
Address: 5016 Watercross Dr NE  
Email: K.Boothe@comcast.net  
Phone: 505-280-8985

Name: Frank Delgado  
Address: 5028 Watercross Dr.  
Phone: 505-554-4411

Name: Russ Harvey  
Address: 5108 Watercross NE  
Albuq, NM 87113  
Phone: 505-239-6719  
email: imca151@msn.com

NAME  
Address  
Phone  
email

Kathy + Pichit Singkanati  
5023 Watercress Dr. N.E.  
Albuquerque, N.M. 87113  
(505) 823-2019  
paulsingkanati@icloud.com

Name Michelle Tirey  
Address 4912 Watercress Dr. N.E.  
Albuquerque, N.M. 87113  
Phone 505-401-9434  
email michelletirey@comcast.net

Name Tony Lovato  
Address 4910 Watercress Dr. N.E.  
Albuquerque, N.M. 87113  
Phone 505-553-5069  
email antonylovato@comcast.net

NAME Regina Solley  
Address 5105 Watercress Dr. N.E. 87113  
Albuq, NM  
Phone 505-220-3625  
email whittier89@msn.com

NAME BARI HARVEY  
Address: 5108 WATERCRESS DR. NE  
Albuq, NM 87113  
Phone: 505-259-5021  
email boyznbari@msn.com



## IN OPPOSITION TO LOCATING THE NEW MEXICO UNITED STADIUM AT BALOON FIESTA PARK

We are opposed to the City of Albuquerque entering in to an agreement with New Mexico United to locate a soccer stadium at Balloon Fiesta Park and are appealing the Albuquerque Environmental Planning Commission's November 16, 2023 decision to amend the park master development plan to allow a multi-use stadium.

We live, do business or own property in close proximity to the park and have serious concerns about noise, lighting and traffic. Based on our experience with activities already existing at the park, the addition of an 8,000 to 10,000 seat open arena hosting soccer games and other activities will further degrade our enjoyment or our property.

Name: Julia Tyack  
Address: 5012 Watercress Drive NE  
Email: julia.tyack@gmail.com  
Phone: (209) 712-0332

Name: Patrick Griffin  
Address: 9624 del Fuego Cir  
Email: patagriffin70@gmail.com  
Phone: 505-315-2536

Name: Larry D McGovern  
Address: 119 Marlowe Ln N.E. Albuq.  
Email: Ldmcgovern41@aol.com  
Phone: 505 389 0138

# IN OPPOSITION TO LOCATING THE NEW MEXICO UNITED STADIUM AT BALOON FIESTA PARK

We are opposed to the City of Albuquerque entering in to an agreement with New Mexico United to locate a soccer stadium at Balloon Fiesta Park and are appealing the Albuquerque Environmental Planning Commission's November 16, 2023 decision to amend the park master development plan to allow a multi-use stadium.

We live, do business or own property in close proximity to the park and have serious concerns about noise, lighting and traffic. Based on our experience with activities already existing at the park, the addition of an 8,000 to 10,000 seat open arena hosting soccer games and other activities will further degrade our enjoyment or our property.

Name: Peggy Brock  
Address: 5015 Watercross NE  
Email: peggybrock61@gmail.com  
Phone: 505-615-2484

Name: Jesse Ruiz  
Address: 121 Marlowe N.E  
Email: Jesse Ruiz 121 @ GMail - COM  
Phone: 505-205-8928

Name: GARY D. BENEDICT  
Address: 113 Ranchitos Rd NW 87114  
Email: \_\_\_\_\_  
Phone: 505 315 2106



# IN OPPOSITION TO LOCATING THE NEW MEXICO UNITED STADIUM AT BALOON FIESTA PARK

We are opposed to the City of Albuquerque entering in to an agreement with New Mexico United to locate a soccer stadium at Balloon Fiesta Park and are appealing the Albuquerque Environmental Planning Commission's November 16, 2023 decision to amend the park master development plan to allow a multi-use stadium.

We live, do business or own property in close proximity to the park and have serious concerns about noise, lighting and traffic. Based on our experience with activities already existing at the park, the addition of an 8,000 to 10,000 seat open arena hosting soccer games and other activities will further degrade our enjoyment or our property.

Name: Anthony Lovato  
Address: 4910 Watercross Dr NE 87113  
Email: antonylovato@comcast.net  
Phone: 505-553-5069

Name: James Welty  
Address: 126 Maria Cir NW  
Email: jawelty@comcast.net  
Phone: 505 269 0536

Name: \_\_\_\_\_  
Address: \_\_\_\_\_  
Email: \_\_\_\_\_  
Phone: \_\_\_\_\_



# IN OPPOSITION TO LOCATING THE NEW MEXICO UNITED STADIUM AT BALOON FIESTA PARK

We are opposed to the City of Albuquerque entering in to an agreement with New Mexico United to locate a soccer stadium at Balloon Fiesta Park and are appealing the Albuquerque Environmental Planning Commission's November 16, 2023 decision to amend the park master development plan to allow a multi-use stadium.

We live, do business or own property in close proximity to the park and have serious concerns about noise, lighting and traffic. Based on our experience with activities already existing at the park, the addition of an 8,000 to 10,000 seat open arena hosting soccer games and other activities will further degrade our enjoyment or our property.

Name: Jacqueline Lance

Address: 10201 Edith Blvd. NE ALBUQUERQUE, NM 87113

Email: jacqueline.lance@yahoo.com

Phone: 505.974-3936

Name: Tania Gonzalez

Address: 10435 Edith Blvd NE

Email: tserafin.30@gmail.com

Phone: (505) 697-9396

Name: Alicia Acosta

Address: 5004 Watercross Dr. NE 87113

Email: lazer@sweet@msn.com

Phone: 310-997-8335

# IN OPPOSITION TO LOCATING THE NEW MEXICO UNITED STADIUM AT BALOON FIESTA PARK

We are opposed to the City of Albuquerque entering in to an agreement with New Mexico United to locate a soccer stadium at Balloon Fiesta Park and are appealing the Albuquerque Environmental Planning Commission's November 16, 2023 decision to amend the park master development plan to allow a multi-use stadium.

We live, do business or own property in close proximity to the park and have serious concerns about noise, lighting and traffic. Based on our experience with activities already existing at the park, the addition of an 8,000 to 10,000 seat open arena hosting soccer games and other activities will further degrade our enjoyment or our property.

Name: Sarah Shortle  
Address: 126 Maria Cir NW  
Email: sarahshortle@comcast.net  
Phone: 505-908-4512

Name: CHARLES E. BATES  
Address: 5000 WATERCRESS DR. NE  
Email: CEBATES67@GMAIL.COM  
Phone: 505 373 7998

Name: Sandra Lovato  
Address: 4910 Watercress Dr NE 87113  
Email: shughes505@a.comcast.net  
Phone: 505 321 9800



# IN OPPOSITION TO LOCATING THE NEW MEXICO UNITED STADIUM AT BALOON FIESTA PARK

We are opposed to the City of Albuquerque entering in to an agreement with New Mexico United to locate a soccer stadium at Balloon Fiesta Park and are appealing the Albuquerque Environmental Planning Commission's November 16, 2023 decision to amend the park master development plan to allow a multi-use stadium.

We live, do business or own property in close proximity to the park and have serious concerns about noise, lighting and traffic. Based on our experience with activities already existing at the park, the addition of an 8,000 to 10,000 seat open arena hosting soccer games and other activities will further degrade our enjoyment or our property.

Name: Lorraine Abeyta

Address: 9614 2nd St. NW

Email: \_\_\_\_\_

Phone: (505) 289-4774

Name: Rob Abeyta

Address: 9614 2nd St NW

Email: \_\_\_\_\_

Phone: (505) 903-4343

Name: \_\_\_\_\_

Address: \_\_\_\_\_

Email: \_\_\_\_\_

Phone: \_\_\_\_\_

# IN OPPOSITION TO LOCATING THE NEW MEXICO UNITED STADIUM AT BALOON FIESTA PARK

We are opposed to the City of Albuquerque entering in to an agreement with New Mexico United to locate a soccer stadium at Balloon Fiesta Park and are appealing the Albuquerque Environmental Planning Commission's November 16, 2023 decision to amend the park master development plan to allow a multi-use stadium.

We live, do business or own property in close proximity to the park and have serious concerns about noise, lighting and traffic. Based on our experience with activities already existing at the park, the addition of an 8,000 to 10,000 seat open arena hosting soccer games and other activities will further degrade our enjoyment or our property.

Name: Brian Anderson  
Address: 5014 Golden Thread NE  
Email: Abqcabinctguy@msn.com  
Phone: 505-~~224~~-259-1270

Name: Jessica Gabriel  
Address: 5018 Verbena Ct  
Email: Chavies@fotoud.com  
Phone: 505-204-1101

Name: MARY MARTINEZ  
Address: 5005 Golden Thread Dr NE ABQ 87113  
Email: MaryOTA@yahoo.com  
Phone: (505) 553-8526



# IN OPPOSITION TO LOCATING THE NEW MEXICO UNITED STADIUM AT BALOON FIESTA PARK

We are opposed to the City of Albuquerque entering in to an agreement with New Mexico United to locate a soccer stadium at Balloon Fiesta Park and are appealing the Albuquerque Environmental Planning Commission's November 16, 2023 decision to amend the park master development plan to allow a multi-use stadium.

We live, do business or own property in close proximity to the park and have serious concerns about noise, lighting and traffic. Based on our experience with activities already existing at the park, the addition of an 8,000 to 10,000 seat open arena hosting soccer games and other activities will further degrade our enjoyment or our property.

Name: Mary Best  
Address: 5010 Golden Thread Dr NE  
Email marybest@comcast.net  
Phone: 505.301.7578

Name: Marvin Best  
Address: 5010 Golden Thread Dr NE  
Email mdbest@comcast.net  
Phone: 505-911-5711

Name: Linda Daniels  
Address: 5014 Golden Thread NE  
Email: redcap@bancor2@msn.com  
Phone: 505-228-0317

# IN OPPOSITION TO LOCATING THE NEW MEXICO UNITED STADIUM AT BALOON FIESTA PARK

We are opposed to the City of Albuquerque entering in to an agreement with New Mexico United to locate a soccer stadium at Balloon Fiesta Park and are appealing the Albuquerque Environmental Planning Commission's November 16, 2023 decision to amend the park master development plan to allow a multi-use stadium.

We live, do business or own property in close proximity to the park and have serious concerns about noise, lighting and traffic. Based on our experience with activities already existing at the park, the addition of an 8,000 to 10,000 seat open arena hosting soccer games and other activities will further degrade our enjoyment or our property.

Name: Joe T. Martinez  
Address: 5107 LARKSPUR LN NE.  
Email: \_\_\_\_\_  
Phone: 505 823-2193

Name: Dominic Lucero  
Address: 5000 Golden Thread Dr NE  
Email: \_\_\_\_\_  
Phone: 505. 821-8497

Name: <sup>LOU.</sup>  
G.L. ATENCIO  
Address: 5001 GOLDENTREAD NE.  
Email: LouABD11@gmail.com  
Phone: 505-401-1753



# IN OPPOSITION TO LOCATING THE NEW MEXICO UNITED STADIUM AT BALOON FIESTA PARK

We are opposed to the City of Albuquerque entering in to an agreement with New Mexico United to locate a soccer stadium at Balloon Fiesta Park and are appealing the Albuquerque Environmental Planning Commission's November 16, 2023 decision to amend the park master development plan to allow a multi-use stadium.

We live, do business or own property in close proximity to the park and have serious concerns about noise, lighting and traffic. Based on our experience with activities already existing at the park, the addition of an 8,000 to 10,000 seat open arena hosting soccer games and other activities will further degrade our enjoyment or our property.

Name: Jeanette Sanchez  
Address: 4908 Golden Thread Dr NE, ABQ, NM 87113  
Email: jsanchez\_681de@msn.com  
Phone: 505-249-6607

Name: Martin Sanchez  
Address: 4908 Golden Thread Dr NE, ABQ, NM 87113  
Email: martinswg@icloud.com  
Phone: 505-249-9700

Name: Jean Chavez  
Address: 5009 Golden Thread Dr NE, ABQ NM 87113  
Email: gjc351@gmail.com  
Phone: 505-315-8188



# IN OPPOSITION TO LOCATING THE NEW MEXICO UNITED STADIUM AT BALOON FIESTA PARK

We are opposed to the City of Albuquerque entering in to an agreement with New Mexico United to locate a soccer stadium at Balloon Fiesta Park and are appealing the Albuquerque Environmental Planning Commission's November 16, 2023 decision to amend the park master development plan to allow a multi-use stadium.

We live, do business or own property in close proximity to the park and have serious concerns about noise, lighting and traffic. Based on our experience with activities already existing at the park, the addition of an 8,000 to 10,000 seat open arena hosting soccer games and other activities will further degrade our enjoyment or our property.

Name: MICHAEL VAN HORN Michael Van Horn  
Address: 8801 COLUMBINE NE  
Email: MVH8@COMCAST.NET  
Phone: 505-934-8903

Name: Jerry Marruto  
Address: 5006 Golden Thread Dr. NE  
Email: \_\_\_\_\_  
Phone: 505-363-0747

Name: Melissa Marruto  
Address: 5006 Golden Thread Dr. NE  
Email: MRS MARRUTO 87 @ yahoo.com  
Phone: 505-414-1278

# IN OPPOSITION TO LOCATING THE NEW MEXICO UNITED STADIUM AT BALOON FIESTA PARK

We are opposed to the City of Albuquerque entering in to an agreement with New Mexico United to locate a soccer stadium at Balloon Fiesta Park and are appealing the Albuquerque Environmental Planning Commission's November 16, 2023 decision to amend the park master development plan to allow a multi-use stadium.

We live, do business or own property in close proximity to the park and have serious concerns about noise, lighting and traffic. Based on our experience with activities already existing at the park, the addition of an 8,000 to 10,000 seat open arena hosting soccer games and other activities will further degrade our enjoyment or our property.

Name: Doug Garrison  
Address: 8913 Blue grass Ct NE  
Email: \_\_\_\_\_  
Phone: 505-697-1026

Name: Natalia Martinez  
Address: 8909 Bluegrass Ct NE  
Email: ~~A~~  
Phone: 505-980-6715

Name: Suzie Lantieri  
Address: 8804 Columbine Dr NE Albu Nm 87113  
Email: americanscale@centurylink.net  
Phone: 505-877-1200



# IN OPPOSITION TO LOCATING THE NEW MEXICO UNITED STADIUM AT BALOON FIESTA PARK

We are opposed to the City of Albuquerque entering in to an agreement with New Mexico United to locate a soccer stadium at Balloon Fiesta Park and are appealing the Albuquerque Environmental Planning Commission's November 16, 2023 decision to amend the park master development plan to allow a multi-use stadium.

We live, do business or own property in close proximity to the park and have serious concerns about noise, lighting and traffic. Based on our experience with activities already existing at the park, the addition of an 8,000 to 10,000 seat open arena hosting soccer games and other activities will further degrade our enjoyment or our property.

Name: PAT LE  
Address: 4909 Golden Thread Dr. NE Albuquerque NM 87113  
Email: PATSYLE29@gmail.com  
Phone: (505) 379-5379

Name: Bernadette D. Lucero  
Address: 4900 Golden Thread Dr NE Alb NM 87113  
Email: bdlucero @ msn.com  
Phone: 505 821-1031

Name: Isaac G Lucero  
Address: 4900 Golden Thread Dr. NE Alb NM 87113  
Email: \_\_\_\_\_  
Phone: 505-821-1031

# IN OPPOSITION TO LOCATING THE NEW MEXICO UNITED STADIUM AT BALOON FIESTA PARK

We are opposed to the City of Albuquerque entering in to an agreement with New Mexico United to locate a soccer stadium at Balloon Fiesta Park and are appealing the Albuquerque Environmental Planning Commission's November 16, 2023 decision to amend the park master development plan to allow a multi-use stadium.

We live, do business or own property in close proximity to the park and have serious concerns about noise, lighting and traffic. Based on our experience with activities already existing at the park, the addition of an 8,000 to 10,000 seat open arena hosting soccer games and other activities will further degrade our enjoyment or our property.

Name: Vicki Maestas  
Address: 4908 Watercress Dr NE Albuquerque NM  
Email: maestas4908@msn.com  
Phone: 505-414-3207

Name: Elmo Maestas  
Address: 4908 Watercress Dr NE Albuquerque NM  
Email: maestas4908@msn.com  
Phone: 505-414-0460

Name: Nicholas Perera  
Address: 4900 Watercress Dr NE  
Email: NPerera@abqwu.org  
Phone: 505-705-4998



# IN OPPOSITION TO LOCATING THE NEW MEXICO UNITED STADIUM AT BALOON FIESTA PARK

We are opposed to the City of Albuquerque entering in to an agreement with New Mexico United to locate a soccer stadium at Balloon Fiesta Park and are appealing the Albuquerque Environmental Planning Commission's November 16, 2023 decision to amend the park master development plan to allow a multi-use stadium.

We live, do business or own property in close proximity to the park and have serious concerns about noise, lighting and traffic. Based on our experience with activities already existing at the park, the addition of an 8,000 to 10,000 seat open arena hosting soccer games and other activities will further degrade our enjoyment or our property.

Name: Priscilla Marrugo  
Address: 5006 Goldenthread Dr  
Email: pmarrugo30@gmail.com  
Phone: (505) 415-2976

Name: Joann K. Cordova  
Address: 5030 Verbena Ct NE  
Email: \_\_\_\_\_  
Phone: 505-550-9677

Name: DIANA DUONG  
Address: 8909 COLUMBINE DR NE  
Email: Qddd 9152@icloud.com  
Phone: 505-440-9282

# IN OPPOSITION TO LOCATING THE NEW MEXICO UNITED STADIUM AT BALOON FIESTA PARK

We are opposed to the City of Albuquerque entering in to an agreement with New Mexico United to locate a soccer stadium at Balloon Fiesta Park and are appealing the Albuquerque Environmental Planning Commission's November 16, 2023 decision to amend the park master development plan to allow a multi-use stadium.

We live, do business or own property in close proximity to the park and have serious concerns about noise, lighting and traffic. Based on our experience with activities already existing at the park, the addition of an 8,000 to 10,000 seat open arena hosting soccer games and other activities will further degrade our enjoyment or our property.

Name: Joann Griego  
Address: 4917 Golden Thread NE  
Email: joann.griego@yahoo.com  
Phone: 505-977-2875

Name: CARLOS GRIEGO  
Address: 4917 GOLDENTHREAD DR. NE  
Email: carlos.griego@q.com  
Phone: 505 967 7414

Name: QUANG DUONG  
Address: 8909 - COLUMBINE DR. NE  
Email: QUANG DUONG 9152 @ YAHOO.COM  
Phone: (505) 818-9699



# IN OPPOSITION TO LOCATING THE NEW MEXICO UNITED STADIUM AT BALOON FIESTA PARK

We are opposed to the City of Albuquerque entering in to an agreement with New Mexico United to locate a soccer stadium at Balloon Fiesta Park and are appealing the Albuquerque Environmental Planning Commission's November 16, 2023 decision to amend the park master development plan to allow a multi-use stadium.

We live, do business or own property in close proximity to the park and have serious concerns about noise, lighting and traffic. Based on our experience with activities already existing at the park, the addition of an 8,000 to 10,000 seat open arena hosting soccer games and other activities will further degrade our enjoyment or our property.

Name: FRANK DELGADO  
Address: 5020 WATERCRESS DR. N.E.  
Email: FRANKDELGADO 171 @ GMAIL  
Phone: 505-554-4411

Name: HELEN C MADRID  
Address: 5020 WATERCRESS DR N.E.  
Email: N/A  
Phone: 505-823-1975

Name: \_\_\_\_\_  
Address: \_\_\_\_\_  
Email: \_\_\_\_\_  
Phone: \_\_\_\_\_

IN OPPOSITION TO LOCATING THE NEW MEXICO UNITED STADIUM AT  
BALLOON FIESTA PARK

We are opposed to the City of Albuquerque entering into an agreement with New Mexico United to locate a soccer stadium at Balloon Fiesta Park and are appealing the Albuquerque Environmental Planning Commission's November 16, 2023, decision to amend the park master development plan to allow a multi-use stadium.

As residents of the Amara Vista Court subdivision, we live in close proximity to the park and have serious concerns about noise, lighting and traffic. Based on our experience with activities already existing at the park, the addition of a 8,000- to 10,000-seat open arena hosting soccer games and other activities will further degrade our enjoyment of our property.

Name: LuElena Gonzales

Address: 10426 Amara Vista Court NE, Albuquerque, NM 87113

Email: luelenagonzales@hotmail.com

Phone: 505.980.1393

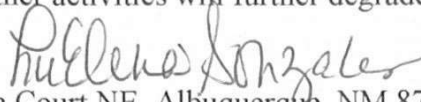

Name: Fred Becker

Address: 10430 Amara Vista Court NE, Albuquerque, NM 87113

Email: fabkab5@hotmail.com

Phone: 505.340.4504

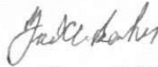

Name: Kathy Becker

Address: 10430 Amara Vista Court NE, Albuquerque, NM 87113

Email: fabkab5@hotmail.com

Phone: 505.280.5867

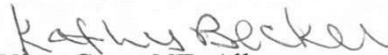

Name: Jaime Baca

Address: 10446 Amara Vista Court NE, Albuquerque, NM 87113

Email: jxmeh@icloud.com

Phone: 505.980.1393



IN OPPOSITION TO LOCATING THE NEW MEXICO UNITED STADIUM AT BALLOON FIESTA PARK

We are opposed to the City of Albuquerque entering into an agreement with New Mexico United to locate a stadium at Balloon Fiesta Park and are appealing the Albuquerque Environmental Planning Commission's November 16, 2023, decision to amend the park's master development plan to allow a multi-use stadium.

We live, do business, or own property in close proximity to the park and have serious concerns about noise, lighting, and traffic. Based on our experience with the activities already existing at the park, the addition of an 8,000- to 10,000-seat open arena hosting soccer games and other activities will further degrade our enjoyment of our property.

Christine Benavidez

Address: 10417 Edith Blvd NE, Albuquerque, NM 87113

Tel. 505-897-3340

Email: christinebnvdz@aol.com

*Christine M Benavidez*

Tania Gonzalez <sup>43</sup>

Address: 10435 Edith Blvd NE, Albuquerque, NM 87113

Tel.: 505-697-9396

Email: Tserafin30@gmail.com

*Tania L Gonzalez*

Patricia Garduno

Address: 8900 Bluegrass Ct NE, Albuquerque, NM 87113

Tel.: 505-263-7346

Email: gardunotrish@yahoo.com

Evelyn Harris

Address: 10401 Edith Blvd NE, Albuquerque, NM 87113

Tel.: 505-379-3693

Email: grumpyeh46@comcast.net

*Evelyn Harris*

Ken Harris

Address: 10401 Edith Blvd NE, Albuquerque, NM 87113

*Ken Harris*

Lorraine & Phil Montoya

Address: 11001.5 Pinto Lane, Albuquerque, NM 87113

Email: alamedamontoya@gmail.com

*Phil Montoya*

*Lorraine Montoya*

Barbara Myers

Address: 105 Baker Ln. NE, Albuquerque, NM 87113

Tel.: 505-898-6910

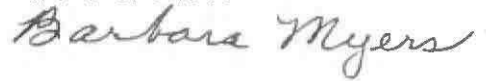

Ben Myers

Address: 105 Baker Ln. NE, Albuquerque, NM 87113

Tel.: 505-898-6910



Chris Myers

Address: 108 Baker Ln. NE, Albuquerque, NM 87113

Tel.: 505-515-6072

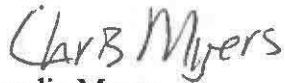

Claudia Myers

Address: 108 Baker LN NE 87113

Tel.: 505-515-6071



Edie Myers

Address: 104 Baker Ln. NE, Albuquerque, NM 87113

Tel.: 505-358-0755

Email: emyers\_11@yahoo.com



Jeanie Stark

Address: 100 Baker Ln. NE, Albuquerque, NM 87113

Tel.: 505-702-5071

Email: j7025071@yahoo.com



Matt Stark

Address: 100 Baker Ln. NE, Albuquerque, NM 87113

Tel.: 505-702-6108

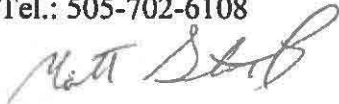



IN OPPOSITION TO LOCATING THE NEW MEXICO UNITED STADIUM AT BALLOON FIESTA PARK

We are opposed to the City of Albuquerque entering into an agreement with New Mexico United to locate a soccer stadium at Balloon Fiesta Park and are appealing the Albuquerque Environmental Planning Commission's November 16, 2023, decision to amend the park master development plan to allow a multi-use stadium.

We live, do business or own property in close proximity to the park and have serious concerns about noise, lighting and traffic. Based on our experience with activities already existing at the park, the addition of a 8,000- to 10,000-seat open arena hosting soccer games and other activities will further degrade our enjoyment of our property.

Name: STEVE HORCHHEIMER  
Address: 10229 EDITH BLVD NE  
Email: STEMAX1@ADL.COM  
Phone: 505 239-0876

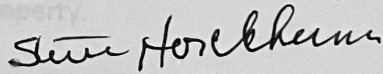
  
ALB NM 87113

Name: ANGELA HORCHHEIMER  
Address: 10229 EDITH BLVD NE  
Email: CIJAMAX@GMAIL.COM  
Phone: 505 231-2099

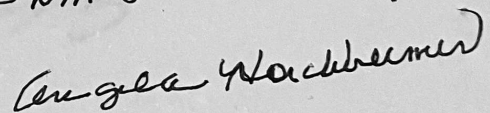
  
ALB NM 87113

Name: TED WATERMAN  
Address: 10217 EDITH, NE  
Email: waterman@watermaninc.net  
Phone: 505-898-0941

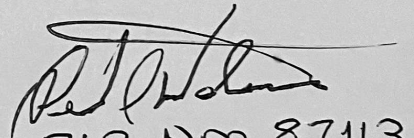
  
ALB, NM 87113

Name: LEE ANN WATERMAN  
Address: 10217 EDITH, NE  
Email: waterman@watermaninc.net  
Phone: 505-898-0941

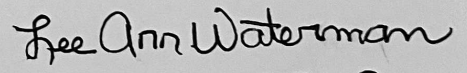
  
ALB, NM 87113

Name: Chris Michel  
Address: 10201 Edith Blvd NE  
Email: chrisnichel70@gmail.com  
Phone: 505-720-5898

ALB NM 87113

Name: Amanda Barclay  
Address: 10201 Edith Blvd NE Albuquerque, NM 87113  
Email: amandabarclay22@yahoo.com  
Phone: 505-903-3697

IN OPPOSITION TO LOCATING THE NEW MEXICO UNITED STADIUM AT BALLOON FIESTA PARK

We are opposed to the City of Albuquerque entering into an agreement with New Mexico United to locate a soccer stadium at Balloon Fiesta Park and are appealing the Albuquerque Environmental Planning Commission's November 16, 2023, decision to amend the park master development plan to allow a multi-use stadium.

We live, do business or own property in close proximity to the park and have serious concerns about noise, lighting and traffic. Based on our experience with activities already existing at the park, the addition of a 8,000- to 10,000-seat open arena hosting soccer games and other activities will further degrade our enjoyment of our property.

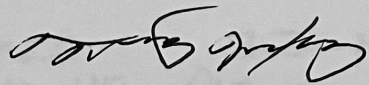
Name: Terry Maxey   
Address: 10201 Edith NE  
Email:  
Phone: 505 8982102

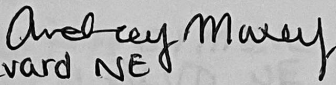
Name: Audrey Maxey   
Address: 10201 Edith Boulevard NE  
Email: [heavymetaldetails@gmail.com](mailto:heavymetaldetails@gmail.com)  
Phone: 505 . 785.2349

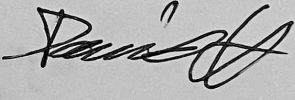
Name: David Hernandez   
Address: 10201 Edith Blvd NE  
Email: [hcdheart@gmail.com](mailto:hcdheart@gmail.com)  
Phone: 505-514-1793

Name: Freda Shoots  
Address: 10201 Edith NE  
Email: [fredashoots@gmail.com](mailto:fredashoots@gmail.com)  
Phone: 505-514-4238

Name:  
Address:  
Email:  
Phone:

Name:  
Address:  
Email:  
Phone:



**Bolivar, Silvia A.**

---

**From:** Maggie Rose <gypsy.rose46@gmail.com>  
**Sent:** Thursday, April 4, 2024 7:29 AM  
**To:** Bolivar, Silvia A.  
**Subject:** Deferral for : EPC hearing

[EXTERNAL] Forward to [phishing@cabq.gov](mailto:phishing@cabq.gov) and delete if an email causes any concern.

Dear Ms. Bolivar,

I have tried to send this letter to two different addresses, I'm not a tech genius so I'm sending this to you in hopes you can get this to the right people on my behalf.

I am asking for a deferral on PR-2-23-009363; S1-2023001635/S1-2023-01638

The purpose of my letter is to request a deferral of the EPC'S hearing on April 11, 2024. I understand this will be a special hearing for the remand of the amendment to the Balloon Fiesta Park Master Development Plan and the Site plan for a multi use stadium.

My phone rings constantly. People are asking if we are ever going to be able to ask questions about this project. I've talked to several people in the US and State Game and Wildlife departments. The wildlife in the Bosque will definitely be affected by the noise, traffic, fireworks, and artificial lights. **Isn't that what the EPC is for to protect the environment?** We have not heard one word about the animals both wild and domestic. The effect of the proposed stadium being so close to the river. Some people have asked me if we are going to lose the International Balloon Fiesta? Now wouldn't that be a crying shame, New Mexico 's number one money maker.

For once think of the impact on the last piece of wildlife we have in the ABQ. metro area. Stop thinking about how much money you can make for a few people. Leave the Balloon Field alone and let Soccer United build elsewhere.

Maggie Rose President Maria Diers Neighborhood Association

**Bolivar, Silvia A.**

---

**From:** Michael Haederle <haederle@yahoo.com>  
**Sent:** Wednesday, April 3, 2024 10:37 PM  
**To:** Bolivar, Silvia A.  
**Cc:** Pat Hauser; Tina Villegas; Brooke Jordy  
**Subject:** Written Comments -- April 11, 2024 Environmental Planning Commission Meeting  
**Attachments:** Balloon Fiesta Park 4.11.24 EPC Hearing.docx

[EXTERNAL] Forward to [phishing@cabq.gov](mailto:phishing@cabq.gov) and delete if an email causes any concern.

Dear Ms. Bolivar:

Please find attached my written comments opposing the planned multi-use stadium at Balloon Fiesta Park. I request that they be included as part of the written record.

Thank you for your consideration.

Regards,

Michael Haederle  
505.453.6072

Dear Ms. Bolivar:

April 3, 2024

I am a resident of North Edith Boulevard in unincorporated Bernalillo County, writing in opposition to the proposed amendment of the Master Development Plan at Balloon Fiesta Park to permit construction of a multi-use stadium at the park.

The planned operation of the stadium – home games for men’s and women’s soccer teams with up to 10,000 fans, plus its unfettered use for other noise-and-light-generating events like concerts, festivals, parties, weddings and the like – amounts to putting an amusement park in our backyards.

There are a number of concerns that we think the city Planning staff and the Environmental Planning Commission should take seriously.

For starters, these uses would violate core provisions of the City of Albuquerque’s Integrated Development Ordinance (IDO). The first of the IDO’s General Provisions – 1-3(A) – states that the IDO’s purpose is to “Implement the adopted Albuquerque/Bernalillo County Comprehensive Plan (ABC Comp Plan), as amended.”

The area along North Edith Boulevard adjacent to the park – the historic Camino Real – retains a quiet, semi-rural character, with predominantly A-1 zoning. Many people follow traditional practices of keeping livestock, cutting hay and maintaining small gardens, with open areas used by waterfowl from the nearby Rio Grande.

This area’s unique character is recognized in the Albuquerque/Bernalillo County Comprehensive Plan: “[T]here are several communities in the unincorporated area that have historic properties worthy of protection. In the North Valley, a number of historic buildings and properties are located along North Edith Boulevard between Osuna Rd. and the Sandia Indian Reservation part of the original El Camino Real route and the road from Albuquerque to Bernalillo.” (p. 11-13)

The Comprehensive Plan further states: “In order for rural and agrarian areas to remain viable and sustainable, efforts to increase density and intensity need to be concentrated in existing urban areas, drawing the gravity of development away from the outlying areas. Additionally, future growth should be respectful of and compatible with the surrounding context, whether urban or rural, to ensure the full range of lifestyle options.” (p. 11-5)

The IDO is also meant to “Protect all communities, especially those that have been historically underserved.” 1-3(D) and “Protect the quality and character of residential neighborhoods.” 1-3(E)

The fact is, construction of a stadium at Balloon Fiesta Park would financially benefit a few business people – the team’s owners – at the expense of hundreds of predominantly Hispanic working-class residents living in neighborhoods adjacent to the park, whose property values would be irreparably damaged.

The IDO is further intended to “Protect the abundant natural resources that characterize Albuquerque, including but not limited to Major Public Open Space, Sensitive Lands, the Rio Grande, and the waterways that lead to the river.” 1-3(L) Locating a multi-use stadium at Balloon Fiesta Park, with its parking and noise impacts, would severely curtail the ability of others to use the park. Loud activities at the stadium – particularly in the evening – would also pose negative impacts to adjacent “sensitive lands,” due to the park’s proximity to the Rio Grande and the North Diversion Channel, which drains into the river.

Finally, the IDO is meant to “Provide reasonable protection from possible nuisances and hazards and to otherwise *protect and improve public health.*” [*italics added*] 1-3(N) The architect for the New Mexico United Soccer team has stated on multiple occasions that the team intends to permit sustained levels of amplified sound at 90 decibels on the playing field.

Guidelines published by the [Centers for Disease Control and Prevention](#) and the [American Speech-Language-Hearing Association](#) state that exposure to sound volumes in that range are likely to cause hearing damage. In the interests of protecting public health, the Environmental Planning Commission (EPC) has an obligation to set reasonable limits on sound levels that would be permitted at the stadium.

Furthermore, the sound study conducted for New Mexico United by a Virginia-based consultant as part of its application relied entirely on simulations, rather than in-situ testing with live sound. North Edith residents with decades of experience living with the noise impacts from events at Balloon Fiesta Park know that amplified sound – particularly bass frequencies – project downhill and across the valley floor at unacceptable levels, to the extent that our walls often vibrate, even with doors and windows closed.

Some EPC commissioners at the November 2023 hearing were dismissive of neighbors’ concerns about sound, suggesting that they could simply be addressed by the city’s existing sound ordinance. However, many North Edith residents can attest to many years of frustration in trying to get Balloon Fiesta Park administrators to enforce that ordinance. In fact, David Simon, the city’s Parks and Recreation director, has admitted that they have historically done a poor job of doing so.

But chronic exposure to noise – intrusive unwanted sound – is more than a mere annoyance. It poses a serious risk for multiple physiological and neurological diseases.

A newly published study in the [Journal of Exposure Science and Environmental Epidemiology](#) states, “Noise is one of the most ubiquitous environmental pollutants, as suggested by reports from the World Health Organization and the European Environment Agency that noise exposure is a major public health threat affecting both physical and mental health.”

The authors, an international group of experts in cardiology and psychiatry, summarize a few of the potential harms this way: “While recent years have yielded a wealth of evidence linking environmental noise exposure primarily to cardiovascular ailments . . . an

increasing body of compelling research and conclusive findings confirms that exposure to noise, particularly from sources such as traffic, can potentially impact the central nervous system. These harms of noise increase the susceptibility to mental health conditions such as depression, anxiety, suicide, and behavioral problems in children and adolescents. From a mechanistic perspective, several investigations propose direct adverse phenotypic changes in brain tissue by noise (e.g. neuroinflammation, cerebral oxidative stress), in addition to feedback signaling by remote organ damage, dysregulated immune cells, and impaired circadian rhythms, which may collectively contribute to noise-dependent impairment of mental health.”

No one, including residents living near the Balloon Park, should be exposed to these hazards. The EPC’s fundamental mission – to consider the potential *environmental* impacts of new development in the city – compels it to seriously weigh these concerns as they pertain to the proposed stadium. At a minimum, the EPC should require significant and demonstrable mitigation of any sound impacts on the surrounding neighborhoods, both by attenuating volumes and limiting the frequency with which noise is produced.

But, given the city’s abysmal record of sound ordinance enforcement at the park, and because New Mexico United is likely unable and/or unwilling to agree to that, the better course would be to deny the Master Development Plan amendment altogether.

The park’s existing Master Development Plan prohibits construction of a stadium for a good reason: it would violate provisions of the Comprehensive Plan and IDO, and it would demonstrably endanger public health, both for those attending events and residents in the surrounding neighborhoods.

Balloon Fiesta Park is clearly not an appropriate location for a multi-use stadium. The city should be held to the commitments it has made to ensure the well-being of *all* of the citizens living in the metropolitan area, not just soccer fans or members of the business community. For these reasons the petition to amend the Master Development Plan must be denied.

Sincerely,

Michael Haederle  
Vice President, North Edith Corridor Association

10312 Edith Boulevard NE  
505.453.6072

**Bolivar, Silvia A.**

---

**From:** Tina Villegas <t-marie-v@hotmail.com>  
**Sent:** Thursday, April 4, 2024 8:03 AM  
**To:** Bolivar, Silvia A.  
**Cc:** Brooke Jordy; hdhauser@comcast.net; Michael Haederle; Sandy Zuschlag; Maggie Rose  
**Subject:** Written Comments -- April 11, 2024 Environmental Planning Commission Meeting  
**Attachments:** 4-11-2024 EPC Hearing Comments - TVillegas.docx

[EXTERNAL] Forward to [phishing@cabq.gov](mailto:phishing@cabq.gov) and delete if an email causes any concern.

Good Morning,

Attached please find my written comments opposing the planned multi-use stadium at Balloon Fiesta Park. I request that they be included as part of the written record.

I also request that the matter be deferred for 90 days due to the fact that the neighborhoods have not been instructed how the cross-examination process will work, how the hearing will be structured and who will be allowed to speak and for how much time, and if any of the previous exhibits and/or comments from the prior hearings will be used or allowed for the new remand hearing.

Thank you for your consideration.

*Tina M. Villegas*

10212 Edith Blvd. NE  
Albuquerque, NM 87113  
505-269-4652



April 4, 2024

**VIA ELECTRONIC MAIL**

Environmental Planning Commission  
City of Albuquerque  
c/o Silvia Bolivar  
[sabolivar@cabq.gov](mailto:sabolivar@cabq.gov)

Subject: Written Comments for the April 11, 2024, EPC Hearing – Proposed Stadium at Balloon Fiesta Park

Dear Ms. Bolivar:

My name is Tina Villegas and I live at 10212 Edith Blvd. NE, Albuquerque, NM 87113, and I am a resident of the North Edith Corridor neighborhood in unincorporated Bernalillo County. I am wholeheartedly opposed to amending the Master Development Plan (MDP) at Balloon Fiesta Park (BFP) that would permit construction of a multi-use stadium at the park.

I have lived in the North Edith Corridor for almost 19 years and my home is only 2,059 feet from the west side of the proposed new stadium. I am most concerned about the noise pollution from the new stadium since New Mexico United (United) is unable to tell us what other events besides soccer will be held at the stadium. Although United has indicated they have improved the stadium design to mitigate noise traveling down to the neighborhoods located to the west, I do not believe they will be able to contain any of the noise unless they put a roof on the stadium. All noise travels down to the lower neighborhoods because I hear most of the events that happen at Balloon Fiesta Park, from the kids practicing soccer, the drones and model airplanes flying around the park, to the larger events such as the Wine Festival, and Freedom 4<sup>th</sup>, to the long 9-days of the Albuquerque International Balloon Fiesta. The sound from the music events and the fireworks often vibrates the windows of my house during events like the Calvary Church Freedom Celebration and the Los Alamos Concert. I have tried contacting the City regarding issues with noise at BFP; however, most times nothing is done.

This is concerning because United keeps telling us that they want to work with the neighborhoods; however, I have only been invited to one meeting held by Consensus Planning and United back in November 2023. A second meeting was held with a mediator on 3/4/2024. United scheduled two additional meetings at their team shop in Nob Hill; however, since I am an appellant in this hearing process, I did not feel comfortable attending without a mediator present. Also, United could not provide the neighborhoods with much information regarding how they would contain the noise

from a stadium of 7,000-10,000 people, and now United indicates it could be 13,000 people. Cheering fans with drums and loud sounding horns. United's own commercials on television indicate they want attendees to "Get Loud". Loud music being played to hype up the crowd, and even the possibility of fireworks. My dogs are very afraid of the fireworks held during the Albuquerque International Balloon Fiesta and I do not wish for them to be further exposed to this type of noise during soccer games. Furthermore, I do not want to pick up the mess left by the firework debris that falls in my yard because I do not want my dogs to think they are chew toys. The local news media also indicates United usually has tailgating events before all games that include bands playing loud music outside of the stadium. Even though United states their games are usually done by 9:00 p.m. my elderly mother-in-law is usually in bed by 7:00 p.m. so why should she be disturbed in her own home by the noise coming from the stadium? I live near several older neighbors who asked me to speak for them that they also do not want their quiet, rural neighborhood disturbed by events held at the stadium.

The stadium will not be in harmony with our neighborhoods which are rural, with small farms, livestock, migratory birds, rabbits, skunks, racoons, and coyotes. The Edith Corridor precedes BFP, and the MDP does not allow for a stadium in the first place.

Also, it would violate provisions of the City of Albuquerque's Integrated Development Ordinance (IDO). The ordinance is meant to "Protect all communities, especially those that have been historically underserved." 1-3(D) and "Protect the quality and character of residential neighborhoods." 1-3(E)

United cannot accurately assess the impact the stadium will have on our neighborhoods in terms of noise. The team's architect said at a meeting with neighbors in March that sound on the field could reach ninety decibels which is more than the sound ordinance allows. Although United indicated they would do another sound study that will measure sound from the proposed stadium area to neighboring houses, that study will not be done until after the EPC has already decided this matter.

Without written assurances from United, how can the neighborhoods understand what types of events will be held at the stadium and how issues with sound will be resolved. United keeps saying they will work with the communities, but we already get that answer from the City which does not help us now, so how can we trust issues will even be investigated once the stadium is built.

United also cannot be sure that light from the stadium will not impact the houses located to the west and northwest. Although United indicates the main lights of the stadium will be positioned as such to project the light downward this may not be enough to keep the light from shining into my upstairs windows at night. What about other lighting outside of the stadium to light walkways and the parking areas? Because

my house sits directly across from the proposed stadium, which is lower than BFP, light pollution could be a factor and once the stadium is built what would be my recourse?

United makes brief mention of a "Community Benefits Program" in the Lease but could not give specifics to the neighborhoods regarding the program when asked at the March 4, 2024, meeting.

A stadium at BFP only benefits the owners of United and would not benefit the surrounding neighborhoods. Instead, it would irreparably affect the property values and causes many more issues for the neighborhoods which the residents do not want or need. Simply put, the neighborhoods do not want a stadium at BFP.

There are several issues which United has not addressed properly regarding the proposed stadium. United keeps stating they will work with the neighborhoods; however, what if issues are not corrected then what recourse will the neighborhoods have once the stadium is built? The EPC is responsible for protecting the residents and property owners from issues such as this and I respectfully request you vote no to amend the MDP at BFP.

Thank you for your time and consideration.

Sincerely,

A handwritten signature in black ink that reads "Tina M. Villegas". The signature is written in a cursive, flowing style.

***Tina M. Villegas***  
10212 Edith Blvd NE  
Albuquerque, NM 87113  
(505) 269-4652

DEFERRAL REQUEST

**From:** [Brooke Jordy](#)  
**To:** [Bolivar, Silvia A.](#); [Planning EPC](#)  
**Subject:** Time-Sensitive Correspondence from Appellants (Appeal No. AC-23-22)  
**Date:** Friday, March 8, 2024 9:12:59 AM  
**Attachments:** [2024.3.8 Appellant Letter to EPC Requesting April 2024 Hearing.pdf](#)

---

**[EXTERNAL]** Forward to [phishing@cabq.gov](mailto:phishing@cabq.gov) and delete if an email causes any concern.

Good morning,

Please see the attached letter from neighbors opposing the stadium in Balloon Fiesta Park. We are formally requesting that the EPC hearing be rescheduled from the March 2024 docket to the April 2024 docket to allow for proper preparation and to comport with due process requirements.

Please do not hesitate to reach out if you have any questions.

All the best,

Brooke Jordy  
575-770-4389

March 7, 2024

Environmental Planning Commission  
City of Albuquerque  
C/O Silvia Bolivar  
[sabolivar@cabq.gov](mailto:sabolivar@cabq.gov)  
[PlanningEPC@cabq.gov](mailto:PlanningEPC@cabq.gov)

**VIA ELECTRONIC MAIL**

*Re: Deferring EPC Hearing on Remand of the Balloon Fiesta Park stadium*

Dear Ms. Bolivar:

We write to you as the neighbors of the areas surrounding Balloon Fiesta Park and as appellants who filed Appeal No. AC-23-22. We were informed of the March 21, 2024 EPC hearing only *after* our independent inquiries to Consensus Planning. **We are formally requesting that the EPC hearing on this matter be set on the April 2024 EPC docket.**

In his February 17, 2024 Remand Order, Land Use Hearing Officer Steven M. Chavez stated the remand must be done *de novo*. See Order, attached hereto as ***Exhibit A***, at 2. Mr. Chavez also stated that the EPC must, as a quasi-judicial body, adhere to “provisions of constitutional due process as well as the fundamental rules of fairness.” Order at 2. It is our understanding that the March 21, 2024 EPC hearing docket will be a busy one; as such, we are concerned that our hearing will be cut short or limited in a way that interferes with due process.

To ensure the EPC hearing conforms to the Remand Order and with *State ex rel. Battershell v. City of Albuquerque*, 1989-NMCA-045, we also formally request that we are notified of the format of the EPC hearing in advance of the hearing. In order for appellants to be fully prepared, we request information on the amount of time we will be permitted to speak and how cross examination of opposing witnesses will be organized. See Remand Order at 2 (“Notice of hearings, the right to be heard, and the right to cross examine witnesses are corner stones of due process.”). Furthermore, holding the EPC hearing in April will allow the City planning staff time to modify their report to the EPC to properly reflect objections from neighbors.

Finally, there are a few outstanding questions neighbors/appellants have posed to the City and Consensus Planning that remain unanswered. Since the Remand Order states the hearing is to be done *de novo*, we request clarification on whether exhibits, comments, or other testimony and evidence from the initial EPC hearing will be included in the new hearing’s record. If it will be included, how will the incorrect information be corrected?

If you have any questions, please do not hesitate to contact Brooke Jordy (575-770-4389; [brookemjordy@gmail.com](mailto:brookemjordy@gmail.com)).

Respectfully submitted,

Neighbor Appellants (see below)



Note: Due to the volume of Appellants in this matter, we do not list all names and contact information for each on every communication from the group. On March 6, 2024, Appellants held a meeting to discuss the status of our appeal. The following individuals requested to be specifically listed on this letter requesting the EPC hearing be held in April 2024.

Brooke Jordy  
Pat Hauser  
Amanda Barclay  
Karen Boothe  
Michael Haederle  
Leslie Linthicum  
Bari Harvey  
Russ Harvey  
Steve Horchheimer  
Rosie Johnson  
Courtney Johnson  
Regina Jolley  
Annette Kitts  
Claudia Myers  
Eddie Myers  
Maggie Rose  
Sarah Shortle  
Steve Taylor  
Michelle Tirey  
Tina Villegas  
Ted Waterman  
Steve Wentworth  
Charles Bates  
Sandra Lovato  
Dorothy Lovato  
Jacqueline Lance  
Tania Gonzales  
Alicia Acosta

**Bolivar, Silvia A.**

---

**From:** Bolivar, Silvia A.  
**Sent:** Monday, March 11, 2024 10:37 AM  
**To:** Sandy Zuschlag  
**Cc:** Brooke Jordy; Pat Hauser; Tina Villegas; Maggie Rose; Michael Haederle; Leslie Linthicum; Kenneth & Evelyn Harris; Jones, Megan D.  
**Subject:** RE: Deferral on Stadium EPC Case?

Good morning,

I've passed along your email to Mrs. Megan Jones, who serves as the Principal Planner for Current Planning. She will be responding to your email regarding the request and has been included in this email thread.

Thank you.

Silvia

SILVIA BOLIVAR, PLA ASLA  
Senior Planner  
Landmarks Commission  
(505) 924-3844  
Email: [sabolivar@cabq.gov](mailto:sabolivar@cabq.gov)  
[cabq.gov/planning](http://cabq.gov/planning)

-----Original Message-----

From: Sandy Zuschlag <[szuschlag58@gmail.com](mailto:szuschlag58@gmail.com)>  
Sent: Monday, March 11, 2024 10:31 AM  
To: Bolivar, Silvia A. <[sabolivar@cabq.gov](mailto:sabolivar@cabq.gov)>  
Cc: Brooke Jordy <[brookemjordy@gmail.com](mailto:brookemjordy@gmail.com)>; Pat Hauser <[hdhauser@comcast.net](mailto:hdhauser@comcast.net)>; Tina Villegas <[t-marie-v@hotmail.com](mailto:t-marie-v@hotmail.com)>; Maggie Rose <[gypsy.rose46@gmail.com](mailto:gypsy.rose46@gmail.com)>; Michael Haederle <[haederle@yahoo.com](mailto:haederle@yahoo.com)>; Leslie Linthicum <[leslielinthicum@gmail.com](mailto:leslielinthicum@gmail.com)>; Kenneth & Evelyn Harris <[grumpyeh46@comcast.net](mailto:grumpyeh46@comcast.net)>  
Subject: Deferral on Stadium EPC Case?

[EXTERNAL] Forward to [phishing@cabq.gov](mailto:phishing@cabq.gov) and delete if an email causes any concern.  
March 11th

Good morning Silvia,

The neighbors have officially requested a deferral for the proposed stadium at Balloon Fiesta Park for the March 21st EPC hearing. Since it is past the 9 am deadline today for comments could you respond and let us know whether the deferral will be granted? Also, could you address the current planning planning I asked in my email this weekend?

If the deferral is not granted, could you explain why?

Thank you, Sandy.

Sent from my iPad=

**From:** [Sandy Zuschlag](#)  
**To:** [Bolivar, Silvia A.](#)  
**Cc:** [Pat Hauser](#); [Brooke Jordy](#); [Tina Villegas](#); [Michael Haederle](#); [Leslie Linthicum](#); [Maggie Rose](#)  
**Subject:** Re: Proposed Stadium at Balloon Fiesta Park, Appeal No. AC-23-22, March 11th EPC Comments  
**Date:** Monday, March 11, 2024 10:43:59 AM

---

[EXTERNAL] Forward to [phishing@cabq.gov](mailto:phishing@cabq.gov) and delete if an email causes any concern.

Silvia thank you for your response. I am still not clear whether the exhibits from the remand hearing and my comments from the previous EPC hearing are included in this review.

I understand you responded to my Friday email but I did not see the answer about these points and the other questions I asked.

Thank you

FYI, it is Ms. Zuschlag

Sent from my iPhone

On Mar 11, 2024, at 10:21 AM, Bolivar, Silvia A. <[sabolivar@cabq.gov](mailto:sabolivar@cabq.gov)> wrote:

Good morning Mrs. Zuschlag,

On Friday, I replied to your email, confirming receipt of the attached files to be incorporated into the staff report.

Silvia



**SILVIA BOLIVAR, PLA ASLA**  
**Senior Planner**  
**Landmarks Commission**  
**(505) 924-3844**  
**Email:** [sabolivar@cabq.gov](mailto:sabolivar@cabq.gov)  
[cabq.gov/planning](http://cabq.gov/planning)

---

**From:** Sandy Zuschlag <[szuschlag58@gmail.com](mailto:szuschlag58@gmail.com)>  
**Sent:** Saturday, March 9, 2024 6:26 AM  
**To:** Bolivar, Silvia A. <[sabolivar@cabq.gov](mailto:sabolivar@cabq.gov)>  
**Subject:** Proposed Stadium at Balloon Fiesta Park, Appeal No. AC-23-22, March 11th

EPC Comments

**[EXTERNAL]** Forward to [phishing@cabq.gov](mailto:phishing@cabq.gov) and delete if an email causes any concern.

March 9th

Good morning Silvia. I am not sure if my original comments or exhibits from the LUHO Remand Hearing are part of the record. I have not included those documents in this email due to the difficulty of responding at a distance. Please let me know if those comments and information are part of the record for EPC.

Thank you for your help.

Sandy Zuschlag  
8105 Irwin St NE  
ABQ, NM 87109

505-250-3798

## Bolivar, Silvia A.

---

**From:** Maggie Rose <gypsy.rose46@gmail.com>  
**Sent:** Thursday, March 21, 2024 4:39 PM  
**To:** Bolivar, Silvia A.; Pat Hauser; Peggy Norton; haederle@yahoo.com; Steve Wentworth; staylor@taylortowers.com; Sarah Shortle; cbear5434@gmail.com; Tina Villegas  
**Subject:** March 21st meeting

[EXTERNAL] Forward to [phishing@cabq.gov](mailto:phishing@cabq.gov) and delete if an email causes any concern.

Dear Ms. Bolivar,

I raised my hand during the discussion this morning but was ignored. All of us in the North valley understand plans have been changed but our communities haven't received anything

I was going to get one FACT on record: Mr. Ron Patel was on television and said he was working with a handful of neighbors. They were listening to them and their concerns. They held a meeting for us but no one showed up. I called someone from 5 different neighborhood associations. No one knew anything about a meeting

How will we be informed of Soccer United Changes? It feels like they are putting in a very loud, busy amusement park in our front yard. It is one thing to move into a neighborhood knowing the noisy park is there, however we were here first.

Has anyone thought about the migration of the geese? It is right through where the proposed stadium would be. We need to talk about livestock, wildlife, waterfowl, or do animals not matter? God put them on this earth for a reason.

What happens to our property values? So many questions and No answers.

Maggie Rose

President of Maria Diers Neighborhood Association.

## Bolivar, Silvia A.

---

**From:** Pat Hauser <hdhauser@comcast.net>  
**Sent:** Thursday, March 21, 2024 7:26 PM  
**To:** 'Maggie Rose'; Bolivar, Silvia A.; 'Peggy Norton'; haederle@yahoo.com; 'Steve Wentworth'; staylor@taylortowers.com; 'Sarah Shortle'; cbear5434@gmail.com; 'Tina Villegas'  
**Subject:** RE: March 21st meeting

[EXTERNAL] Forward to [phishing@cabq.gov](mailto:phishing@cabq.gov) and delete if an email causes any concern.

Thanks Maggie for sending in the comments to Ms. Bolivar. Wonder if they will make it into the record?

Each of us will continue to keep forging ahead on this issue. 😊 Pat

---

**From:** Maggie Rose <gypsy.rose46@gmail.com>  
**Sent:** Thursday, March 21, 2024 4:39 PM  
**To:** Silvia Bolivar <sabolivar@cabq.gov>; Pat Hauser <hdhauser@comcast.net>; Peggy Norton <peggynorton@yahoo.com>; haederle@yahoo.com; Steve Wentworth <swent999@aol.com>; staylor@taylortowers.com; Sarah Shortle <sarahshortle@comcast.net>; cbear5434@gmail.com; Tina Villegas <t-marie-v@hotmail.com>  
**Subject:** March 21st meeting

Dear Ms. Bolivar,

I raised my hand during the discussion this morning but was ignored. All of us in the North valley understand plans have been changed but our communities haven't received anything

.  
I was going to get one FACT on record: Mr. Ron Patel was on television and said he was working with a handful of neighbors. They were listening to them and their concerns. They held a meeting for us but no one showed up. I called someone from 5 different neighborhood associations. No one knew anything about a meeting

.  
How will we be informed of Soccer United Changes? It feels like they are putting in a very loud, busy amusement park in our front yard. It is one thing to move into a neighborhood knowing the noisy park is there, however we were here first.

Has anyone thought about the migration of the geese? It is right through where the proposed stadium would be. We need to talk about livestock, wildlife, waterfowl, or do animals not matter? God put them on this earth for a reason.

What happens to our property values? So many questions and No answers.

Maggie Rose

President of Maria Diers Neighborhood Association.



**Bolivar, Silvia A.**

---

**From:** Pat Hauser <hdhauser@comcast.net>  
**Sent:** Thursday, March 21, 2024 9:43 AM  
**To:** 'Peggy Norton'  
**Cc:** Maggie Rose; Michael Haederle; sarahshortle@comcast.net; Sandy Zuschlag; Steve Taylor; swent999@aol.com; t-marie-v@hotmail.com; 'Annette Kitts'; Brooke Jordy; 'Leslie Linthicum'; boyznbari@msn.com; emyers\_11@yahoo.com; Bolivar, Silvia A.; Evelyn Harris  
**Subject:** RE: epc

[EXTERNAL] Forward to [phishing@cabq.gov](mailto:phishing@cabq.gov) and delete if an email causes any concern.

Thanks !!!!!!!!!!! Just went back to the meeting and saw what you had suggested. I had no idea until now. THANKS !!!!!!!!!!!!!!!

Would help if some of this was explained for us street people. 😊

I will send this out to others. Pat

---

**From:** Peggy Norton <peggynorton@yahoo.com>  
**Sent:** Thursday, March 21, 2024 9:25 AM  
**To:** Pat Hauser <hdhauser@comcast.net>  
**Subject:** epc

That was exciting. If you want to raise your hand, you can click on reactions at the bottom and there should be a raise hand, which pops up a yellow hand. It seemed there was no allowed public comment.

Peggy

**Bolivar, Silvia A.**

---

**From:** Pat Hauser <hdhauser@comcast.net>  
**Sent:** Wednesday, April 3, 2024 8:34 PM  
**To:** Bolivar, Silvia A.; Jones, Megan D.  
**Cc:** Maggie Rose; Annette Kitts; 'Sarah Shortle'; Michael Haederle; Sandy Zuschlag; Brooke Jordy; 'Steve Wentworth'; Peggy Norton; Steve Taylor; t-marie-v@hotmail.com; boyznbari@msn.com; Christine Benavidez; Evelyn Harris; wbenson@berncos.gov; kholmes@scates@gmail.com  
**Subject:** 90 Day Deferral Request NO.AC-23-22 PR-2023-0093363; SI-2023-01635; SI-2023-01638  
**Attachments:** Appeal 90 Day Deferral.pdf; AC-23-22 Remand.2-17-24.pdf

[EXTERNAL] Forward to [phishing@cabq.gov](mailto:phishing@cabq.gov) and delete if an email causes any concern.

Good Evening Ms. Bolivar: Attached is my request for a 90 day deferral along with the attached document from the Land Use Hearing Officer Dated February 17, 2024 regarding the above reference.

Would you please acknowledge receipt of these documents and verification that they have been entered in to the record for the EPC to review the 90 day referral request prior to the March 11 special hearing?

Regards: Pat Hauser

April 3, 2024

Environmental Planning Commission  
City of Albuquerque  
c/o Silvia Bolivar  
[sabolivar@cabq.gov](mailto:sabolivar@cabq.gov)  
Megan D. Jones  
[mdjones@cabq.gov](mailto:mdjones@cabq.gov)

Via Electronic mail

**Subject: 90-day deferral request regarding PR-2023-009363; SI2023-01635/SI-2023-01638**

Ms. Bolivar on behalf of Mr. Jonathan Hollinger, Chair:

The purpose of this letter is to request a 90-day deferral of the above referenced request to the Environmental Planning Commission hearing on or about June 13, 2024. We understand this would be a special hearing for the remanded decision issued by the Land Use Hearing Officer February 17, 2024 regarding an amendment to the Balloon Fiesta Master Development Plan and the site Plan-EPC for a multi-use stadium. (Attached)

My name is Mr. Pat Hauser. I live a 134 Maria Circle NW, Albuquerque, NM 87114. Due West of Balloon Fiesta Park. We have lived in this once quiet Far North Valley Neighborhood for 57 years. As such we have endured the tolerated and impact of Balloon Fiesta 9 days a year with the fireworks, traffic along with the other continually growing events over the years such as the Freedom 4<sup>th</sup> fireworks, Wine Festival, concerts, rock bands and daily activities such as youth soccer, RC aircraft, along with other untold sound invasion that has gone on unaddressed with the City Parks and Recreation Department.

We have received reports that there have been information releases by the applicant regarding changes to the original stadium plans. As of today, we have not been contacted by the applicant regarding such changes.

There have been no on-site real time sound studies to properly understand the immediate and long-term impacts on the surrounding homes and neighborhoods with an untold usage of such a facility by the applicants. It is documented that such facilities will operate in excess of hundreds of scheduled events per year. When a single community, and especially one of smaller homes with middle to lower income strata residents have imposed upon them the highly negative and regular impacts of such a venue as a multi-use stadium the tenants of Environmental Justice are clearly at play. Our nearby neighborhoods should not have to shoulder that burden and the Federal Environmental Laws and Federal impact funds and credits/detriments for such impacts must be imposed.

We the people ask for this 90-day deferral consideration thus allowing the needed time to properly prepare to deliver to the EPC why we vehemently oppose the proposed amendment of the Master Development Plan at Balloon Fiesta Park to permit construction of a multi-use stadium and subsequent impact of Environmental Justice on our community and forever homes.

Regards:

*Pat Hauser*

Mr. Pat Hauser  
134 Maria Circle N.W.  
Albuquerque, New Mexico 87114  
Cell: 505-228-7106

Attachment:

Copy:

Maggie Rose  
Annette Kitts  
Sarah Shortle  
Michael Haederle  
Sandy Zuschlag  
Brooke Jordy  
Steve Wentworth  
Peggy Norton  
Tina Villegas  
Beri Harvey  
Christine Benavidez  
Evelyn Harris  
Walt Benson  
Kathleen Cates

**Bolivar, Silvia A.**

---

**From:** Brooke Jordy <brookemjordy@gmail.com>  
**Sent:** Wednesday, April 3, 2024 9:16 PM  
**To:** Bolivar, Silvia A.  
**Subject:** Comments for April 11th EPC Hearing on Stadium  
**Attachments:** 2024.4.11 EPC Hearing Comments - Brooke Jordy.docx.pdf

[EXTERNAL] Forward to [phishing@cabq.gov](mailto:phishing@cabq.gov) and delete if an email causes any concern.

Good evening, Ms. Bolivar,

Please find attached my written comments opposing a multi-use stadium being built in Balloon Fiesta Park. Also attached are the dozens of signatures of neighbors opposing the stadium (sent as a Google Drive link, since the file is so large). I request that all attachments be included in the formal record.

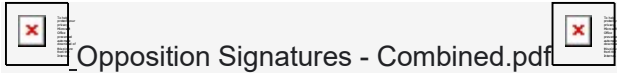

I want to note a few things for you:

1. Neighbors have yet to be informed how they will be permitted to cross examine opponents at the EPC hearing
2. Neighbors have yet to be informed of the format of the hearing (how much time, whether speakers can yield their time to others, etc.). We have requested this information many, many times.
3. Neighbors are requesting a 90-day deferral of the April 11th hearing.

All the best,

Brooke Jordy

April 3, 2024

Environmental Planning Commission  
City of Albuquerque  
c/o Silvia Bolivar  
sabolivar@cabq.gov

**Via Electronic Mail**

Re: *Written Comments for April 11, 2024 Hearing – Balloon Fiesta Park Stadium*

Dear Ms. Bolivar:

My name is Brooke Jordy. I live at 9629 Del Fuego Cir NE, Albuquerque, NM 87113 in the North Edith Corridor neighborhood. Our quiet, rustic neighborhood borders Balloon Fiesta Park. As an affected neighbor, my comments pertaining to the New Mexico United/City of Albuquerque proposal to erect a multi-use stadium in Balloon Fiesta Park are included herein for consideration by the EPC. I vehemently oppose the proposed amendment of the Master Development Plan at Balloon Fiesta Park to permit construction of a multi-use stadium at the park. I am including with this letter the signatures of **dozens** of neighbors from areas immediately surrounding the Park who also oppose building a stadium within Balloon Fiesta Park.

On February 16, 2024, a land use hearing officer granted the neighbors' appeal on due process violations made by Consensus Planning. Hearing Officer Chavez's order stated the appeal is to be done *de novo* and the next EPC hearing shall follow *State ex rel. Battershell v. City of Albuquerque*, 1989-NMCA-045. It has yet to be understood by Consensus Planning that this is a *de novo* appeal; as such, many individuals have yet to receive notice of the March 21st EPC hearing. **The neighbors/appellants request a 90-day deferral of this hearing.** Somehow, Consensus Planning and the City were able to coordinate a reset from March 21, 2024 to April 11, 2024. Neighbors were not asked for their position on rescheduling to this date. Many key speakers for the neighbors—myself included—are unavailable on April 11th. We have also heard through the grapevine that New Mexico United has allegedly made changes to their stadium plans. We have yet to see those changes, and need additional time to review the updated plans for any EPC hearing.

**BACKGROUND**

My husband and I purchased our home—our first—primarily for the location. Living in this part of the North Valley is reminiscent for both of us of growing up in Las Cruces (my husband) and Taos (myself). We chose to buy our first home here to start our family because it is a quiet, rustic area with generational homes. There is more wildlife, livestock, and migratory birds here than most of Albuquerque. Our neighbors use the acequias to water their hay fields, sheep, goats, apple trees, and more. At night, the neighborhood is quiet with little light and no street lights. We can see the stars. I have to check my yard to make sure skunks and racoons are gone before I let my dogs out at night.

Of course, we chose this location knowing the Balloon Fiesta would impact our lives about 9 days a year. However, being so well-established, the Balloon Fiesta employs contractors to monitor sound throughout the Fiesta. The Balloon Fiesta is better at adjusting amplified sound than the City is for other events held throughout the year. During the Fiesta, residents in surrounding areas are given



access permits and roadblocks are set up throughout neighborhoods to ensure there is little to no off-site parking on side streets. Of course, taxpayers cover the cost of law enforcement for these road closures and restrictions. However, for 9 days out of a year, it is tolerable.

There are fireworks 2-3 times per Fiesta. Luckily, my dogs are calm and just hide under the couch. For many others, however, this is their nightmare. More pets escape and run away during Fourth of July, for example, than any other night. Livestock are negatively impacted by fireworks, as are wildlife. The City sets off Fourth of July fireworks from the end of Edith. Many of my neighbors experience literal fallout from those fireworks—fireworks cartridges, gunpowder, and other detritus litter their properties. The air is full of smoke and remains hazy for hours. Veterans and others with PTSD suffer, as well. Fireworks pollute.<sup>1</sup>

## ENVIRONMENTAL IMPACTS

Building a stadium in this otherwise quiet, semi-rural area will introduce noise, light, water, and air pollution to our environment. New Mexico United sets off fireworks regularly. Their fans tailgate; they play drums, set off smoke bombs, yell, and blow vuvuzelas<sup>2</sup> throughout soccer matches. During each game, the team's fan club has a "noisy minute" where the stadium attendees make as much noise as possible.<sup>3</sup>

**Noise Pollution.** Amplified sound from a stadium would create relentless disruption and frustration both for neighbors, animals, and the environment. The Albuquerque Box, the unique weather pattern in our city that makes the Balloon Fiesta an international phenomenon, creates drainage winds that travel in an abnormal pattern.<sup>4</sup> Like the balloons that are carried from the Park to the west over our neighborhood, noise is also carried from the Park to the north and the west. Individuals in the Maria Diers neighborhood, for example, can hear non-amplified sound from the Park. Erecting a stadium in the Park will bring amplified and non-amplified noise to our quiet area. United has stated there will be numerous events at the stadium—concerts, private parties, women's soccer and men's soccer games, etc. However, there are no restrictions in the team's lease to limit events, noise levels, or noise monitoring requirements. Additionally, fireworks bring significant noise pollution to the area. Increasing soccer games and events at the Park will increase fireworks at the Park.

**Light Pollution.** A stadium, no matter how careful its architects are, necessarily brings light pollution. Headlights, parking lights, and stadium and field lights will pollute the relatively dark skies in this section of Albuquerque. Since the Park is situated at a higher elevation than neighborhoods west of the park, lights from the field and the Park shine down on hundreds, potentially thousands, of homes to the west. Even people in Rio Rancho and the Westside of Albuquerque report being

---

<sup>1</sup> Earth.org, *Crowd-Pleasing Fireworks Are Not So Pleasing to the Planet*, available at <https://earth.org/environmental-impact-of-fireworks/>.

<sup>2</sup> Discovery, *Annoying Vuvuzelas Explained*, available at <https://www.youtube.com/watch?v=X15iQFKyqxw>.

<sup>3</sup> KOAT.com, *History and Traditions of New Mexico United*, available at <https://www.koat.com/article/new-mexico-united-history-fan-culture-2024-season/60051431>.

<sup>4</sup> Weather.gov, *Balloon Fiesta Feature*, available at <https://www.weather.gov/media/abq/Briefings/BalloonFiestaFeatureNew.pdf>.

able to see the lights from the Park. Migratory birds from the Bosque will be negatively impacted by increased light pollution in the area.<sup>5</sup>

**Water Pollution.** Balloon Fiesta Park borders the North Diversion Channel, which carries Albuquerque’s stormwater runoff to the Rio Grande. There also exists a maze of acequias throughout the North Valley, which residents use to water their livestock and agriculture. Fallout from fireworks at the stadium will land in the acequias and the North Diversion Channel, poisoning so many throughout the Valley and downstream.

**Traffic & Emissions.** Increasing the frequency and volume of vehicles visiting Balloon Fiesta Park to attend stadium events will also bring problematic traffic and air pollution. Vehicle emissions are responsible for soot, smog, and carbon dioxide pollution.<sup>6</sup> In 2023, “Albuquerque was named one of the top 25 worst cities in the nation for ozone pollution.”<sup>7</sup> Building yet another stadium and event center, especially so close to the river and Diversion Channel, is unnecessary and threatens the environmental future of so many New Mexicans.

## VIOLATIONS OF IDO

Amending the Park’s Master Development Plan to allow a multi-use stadium to be built would violate core provisions of the City of Albuquerque’s Integrated Development Ordinance (IDO). The IDO is intended to “Protect the abundant natural resources that characterize Albuquerque, including but not limited to Major Public Open Space, Sensitive Lands, the Rio Grande, and the waterways that lead to the river.” Section 1-3(L). Locating a multi-use stadium at Balloon Fiesta Park poses significant negative impacts to adjacent “sensitive lands” due to the Park’s proximity to the Rio Grande and the North Diversion Channel. Increasing light and noise pollution in close proximity to migrating birds and other protected species that inhabit the Bosque will negatively impact those species. Further, the IDO is intended to “provide reasonable protection from possible nuisances and hazards and to otherwise protect and improve public health.” Section 1-3(N). The architect for the United stadium has stated on multiple occasions that the team intends to permit sustained levels of amplified sound at 90 decibels on the playing field.

## USE OF PUBLIC FUNDS

The State and City have pledged approximately \$25,000,000 in capital outlay funds to this project. While United and the City both claim taxpayer money is not being spent on the stadium build, Lawrence Rael made the reality clear at the November 16, 2023 City Council meeting. At that meeting, he was asked what the capital outlay funds would be used on if not this project. Mr. Rael responded that if a stadium is not built, the funds would not be spent to improve Balloon Fiesta Park.

---

<sup>5</sup> U.S. Fish & Wildlife Service, *Threats to Birds: Collisions – Nighttime Lighting*, available at <https://www.fws.gov/story/threats-birds-collisions-nighttime-lighting#:~:text=Why%20is%20this%20harmful%20to,colliding%20with%20buildings%20and%20infrastructure>; United Nations, *The Growing Effects of Light Pollution on Migratory Birds*, available at <https://www.un.org/en/un-chronicle/growing-effects-light-pollution-migratory-birds>.

<sup>6</sup> U.S. Environmental Planning Agency, *Smog, Soot, and Other Air Pollution from Transportation*, available at <https://www.epa.gov/transportation-air-pollution-and-climate-change/smog-soot-and-other-air-pollution-transportation>

<sup>7</sup> American Lung Association, Press Release, April 18, 2023, available at <https://www.lung.org/media/press-releases/nm-sota-23>.

## LEASE AGREEMENT

On November 16, 2023, the Albuquerque City Council approved an insufficient lease agreement with New Mexico United for their use of the stadium. This short, vague lease is nothing short of ridiculous. To permit a for-profit company to pay only \$35,000 per year for 7 acres of property is unheard of. The City's lack of concern for specific terms in the lease is problematic and will likely result in United taking advantage of the terms. I urge the EPC to consider the long-term impacts of approving a stadium build, including but not limited to the problems posed by such a vague lease benefitting a for-profit company.

## CONCLUSION

I strongly oppose approving the site plan to build a multi-use stadium within Balloon Fiesta Park. A stadium will bring noise, light, water, and air pollution to a semi-rural area. It will negatively impact wildlife and livestock in the area, including migrating birds. There is no way to un-ring the bell once this is done. This area already bears the brunt of Balloon Fiesta and the Fourth of July, along with hundreds of other events at the Park each year. I encourage the EPC to take this opportunity to ensure that the environmental future of Albuquerque, the North Edith Corridor, and surrounding neighborhoods are all protected.

Respectfully submitted,



---

Brooke Jordy

cell: 575-770-4389

brookemjordy@gmail.com

**Bolivar, Silvia A.**

---

**From:** Michael Haederle <haederle@yahoo.com>  
**Sent:** Wednesday, April 3, 2024 10:37 PM  
**To:** Bolivar, Silvia A.  
**Cc:** Pat Hauser; Tina Villegas; Brooke Jordy  
**Subject:** Written Comments -- April 11, 2024 Environmental Planning Commission Meeting  
**Attachments:** Balloon Fiesta Park 4.11.24 EPC Hearing.docx

[EXTERNAL] Forward to [phishing@cabq.gov](mailto:phishing@cabq.gov) and delete if an email causes any concern.

Dear Ms. Bolivar:

Please find attached my written comments opposing the planned multi-use stadium at Balloon Fiesta Park. I request that they be included as part of the written record.

Thank you for your consideration.

Regards,

Michael Haederle  
505.453.6072

Dear Ms. Bolivar:

April 3, 2024

I am a resident of North Edith Boulevard in unincorporated Bernalillo County, writing in opposition to the proposed amendment of the Master Development Plan at Balloon Fiesta Park to permit construction of a multi-use stadium at the park.

The planned operation of the stadium – home games for men’s and women’s soccer teams with up to 10,000 fans, plus its unfettered use for other noise-and-light-generating events like concerts, festivals, parties, weddings and the like – amounts to putting an amusement park in our backyards.

There are a number of concerns that we think the city Planning staff and the Environmental Planning Commission should take seriously.

For starters, these uses would violate core provisions of the City of Albuquerque’s Integrated Development Ordinance (IDO). The first of the IDO’s General Provisions – 1-3(A) – states that the IDO’s purpose is to “Implement the adopted Albuquerque/Bernalillo County Comprehensive Plan (ABC Comp Plan), as amended.”

The area along North Edith Boulevard adjacent to the park – the historic Camino Real – retains a quiet, semi-rural character, with predominantly A-1 zoning. Many people follow traditional practices of keeping livestock, cutting hay and maintaining small gardens, with open areas used by waterfowl from the nearby Rio Grande.

This area’s unique character is recognized in the Albuquerque/Bernalillo County Comprehensive Plan: “[T]here are several communities in the unincorporated area that have historic properties worthy of protection. In the North Valley, a number of historic buildings and properties are located along North Edith Boulevard between Osuna Rd. and the Sandia Indian Reservation part of the original El Camino Real route and the road from Albuquerque to Bernalillo.” (p. 11-13)

The Comprehensive Plan further states: “In order for rural and agrarian areas to remain viable and sustainable, efforts to increase density and intensity need to be concentrated in existing urban areas, drawing the gravity of development away from the outlying areas. Additionally, future growth should be respectful of and compatible with the surrounding context, whether urban or rural, to ensure the full range of lifestyle options.” (p. 11-5)

The IDO is also meant to “Protect all communities, especially those that have been historically underserved.” 1-3(D) and “Protect the quality and character of residential neighborhoods.” 1-3(E)

The fact is, construction of a stadium at Balloon Fiesta Park would financially benefit a few business people – the team’s owners – at the expense of hundreds of predominantly Hispanic working-class residents living in neighborhoods adjacent to the park, whose property values would be irreparably damaged.

The IDO is further intended to “Protect the abundant natural resources that characterize Albuquerque, including but not limited to Major Public Open Space, Sensitive Lands, the Rio Grande, and the waterways that lead to the river.” 1-3(L) Locating a multi-use stadium at Balloon Fiesta Park, with its parking and noise impacts, would severely curtail the ability of others to use the park. Loud activities at the stadium – particularly in the evening – would also pose negative impacts to adjacent “sensitive lands,” due to the park’s proximity to the Rio Grande and the North Diversion Channel, which drains into the river.

Finally, the IDO is meant to “Provide reasonable protection from possible nuisances and hazards and to otherwise *protect and improve public health.*” [*italics added*] 1-3(N) The architect for the New Mexico United Soccer team has stated on multiple occasions that the team intends to permit sustained levels of amplified sound at 90 decibels on the playing field.

Guidelines published by the [Centers for Disease Control and Prevention](#) and the [American Speech-Language-Hearing Association](#) state that exposure to sound volumes in that range are likely to cause hearing damage. In the interests of protecting public health, the Environmental Planning Commission (EPC) has an obligation to set reasonable limits on sound levels that would be permitted at the stadium.

Furthermore, the sound study conducted for New Mexico United by a Virginia-based consultant as part of its application relied entirely on simulations, rather than in-situ testing with live sound. North Edith residents with decades of experience living with the noise impacts from events at Balloon Fiesta Park know that amplified sound – particularly bass frequencies – project downhill and across the valley floor at unacceptable levels, to the extent that our walls often vibrate, even with doors and windows closed.

Some EPC commissioners at the November 2023 hearing were dismissive of neighbors’ concerns about sound, suggesting that they could simply be addressed by the city’s existing sound ordinance. However, many North Edith residents can attest to many years of frustration in trying to get Balloon Fiesta Park administrators to enforce that ordinance. In fact, David Simon, the city’s Parks and Recreation director, has admitted that they have historically done a poor job of doing so.

But chronic exposure to noise – intrusive unwanted sound – is more than a mere annoyance. It poses a serious risk for multiple physiological and neurological diseases.

A newly published study in the [Journal of Exposure Science and Environmental Epidemiology](#) states, “Noise is one of the most ubiquitous environmental pollutants, as suggested by reports from the World Health Organization and the European Environment Agency that noise exposure is a major public health threat affecting both physical and mental health.”

The authors, an international group of experts in cardiology and psychiatry, summarize a few of the potential harms this way: “While recent years have yielded a wealth of evidence linking environmental noise exposure primarily to cardiovascular ailments . . . an



increasing body of compelling research and conclusive findings confirms that exposure to noise, particularly from sources such as traffic, can potentially impact the central nervous system. These harms of noise increase the susceptibility to mental health conditions such as depression, anxiety, suicide, and behavioral problems in children and adolescents. From a mechanistic perspective, several investigations propose direct adverse phenotypic changes in brain tissue by noise (e.g. neuroinflammation, cerebral oxidative stress), in addition to feedback signaling by remote organ damage, dysregulated immune cells, and impaired circadian rhythms, which may collectively contribute to noise-dependent impairment of mental health.”

No one, including residents living near the Balloon Park, should be exposed to these hazards. The EPC’s fundamental mission – to consider the potential *environmental* impacts of new development in the city – compels it to seriously weigh these concerns as they pertain to the proposed stadium. At a minimum, the EPC should require significant and demonstrable mitigation of any sound impacts on the surrounding neighborhoods, both by attenuating volumes and limiting the frequency with which noise is produced.

But, given the city’s abysmal record of sound ordinance enforcement at the park, and because New Mexico United is likely unable and/or unwilling to agree to that, the better course would be to deny the Master Development Plan amendment altogether.

The park’s existing Master Development Plan prohibits construction of a stadium for a good reason: it would violate provisions of the Comprehensive Plan and IDO, and it would demonstrably endanger public health, both for those attending events and residents in the surrounding neighborhoods.

Balloon Fiesta Park is clearly not an appropriate location for a multi-use stadium. The city should be held to the commitments it has made to ensure the well-being of *all* of the citizens living in the metropolitan area, not just soccer fans or members of the business community. For these reasons the petition to amend the Master Development Plan must be denied.

Sincerely,

Michael Haederle  
Vice President, North Edith Corridor Association

10312 Edith Boulevard NE  
505.453.6072

**Bolivar, Silvia A.**

---

**From:** Maggie Rose <gypsy.rose46@gmail.com>  
**Sent:** Thursday, April 4, 2024 7:29 AM  
**To:** Bolivar, Silvia A.  
**Subject:** Deferral for : EPC hearing

[EXTERNAL] Forward to [phishing@cabq.gov](mailto:phishing@cabq.gov) and delete if an email causes any concern.

Dear Ms. Bolivar,

I have tried to send this letter to two different addresses, I'm not a tech genius so I'm sending this to you in hopes you can get this to the right people on my behalf.

I am asking for a deferral on PR-2-23-009363; S1-2023001635/S1-2023-01638

The purpose of my letter is to request a deferral of the EPC'S hearing on April 11, 2024. I understand this will be a special hearing for the remand of the amendment to the Balloon Fiesta Park Master Development Plan and the Site plan for a multi use stadium.

My phone rings constantly. People are asking if we are ever going to be able to ask questions about this project. I've talked to several people in the US and State Game and Wildlife departments. The wildlife in the Bosque will definitely be affected by the noise, traffic, fireworks, and artificial lights. **Isn't that what the EPC is for to protect the environment?** We have not heard one word about the animals both wild and domestic. The effect of the proposed stadium being so close to the river. Some people have asked me if we are going to lose the International Balloon Fiesta? Now wouldn't that be a crying shame, New Mexico 's number one money maker.

For once think of the impact on the last piece of wildlife we have in the ABQ. metro area. Stop thinking about how much money you can make for a few people. Leave the Balloon Field alone and let Soccer United build elsewhere.

Maggie Rose President Maria Diers Neighborhood Association

**Bolivar, Silvia A.**

---

**From:** Sandy Zuschlag <szuschlag58@gmail.com>  
**Sent:** Wednesday, April 3, 2024 9:06 PM  
**To:** Bolivar, Silvia A.; Jones, Megan D.  
**Cc:** Brooke Jordy; Maggie Rose; Annette Kitts; Steve Wentworth; Steve Taylor; Steve Horchheimer; Tania Serafin; Michael Haederle; Leslie Linthicum; Peggy Norton; Tina Villegas; BARI Harvey; Christine Benavidez; Kenneth & Evelyn Harris  
**Subject:** Deferral Request NO.AC-23-22 PR-2023-0093363; SI-2023-01635; SI-2023-01638  
**Attachments:** EPC request deferral 4-3-24.pdf

[EXTERNAL] Forward to [phishing@cabq.gov](mailto:phishing@cabq.gov) and delete if an email causes any concern.

April 3, 2024

Good evening Ms Bolivar,

Attached is my letter requesting a minimum 90 day deferral in regards to the above captioned project (proposed stadium at Balloon Fiesta Park).

Please provide an acknowledgement concerning the receipt of this email.

Thank you.

Sandy Zuschlag  
505-250-3798

April 3, 2024

Ms. Silvia Bolivar, on behalf of  
Mr. Jonathan Hollinger, Chair  
Environmental Planning Commission  
City of Albuquerque  
600 Second Street NW  
Albuquerque, NM 87102

Re: **PR-2023-009363; SI-2023-01635/SI-2023-01638**  
**Proposed Stadium at Balloon Fiesta Park**

Dear Mr. Chairman:

This letter requests a minimum 90-day deferral of PR-2023-009363; SI-2023-01635/SI-2023-01638 to the June 13, 2024, Environmental Planning Commission's meeting, or longer.

1. Adding a multi-use stadium in Balloon Fiesta Park will significantly change the Master Development Plan, and the environmental impact on the neighborhoods will be severe. The Master Development Plan was updated and approved in 2012. Twelve years have passed, and the existing conditions considering current ecological effects on the neighborhoods and community should be considered. My November 5, 2023, letter to EPC outlined areas of the Master Development that should be updated. Allowing the stadium to be built in the park without understanding the impacts on the neighborhoods is wrong. Amplified sounds and lights from events and the park activities impact the neighborhoods.
2. The Balloon Fiesta Master Development Plan required the review and recommendation from the Balloon Fiesta Park Commission. City Council adopted an Ordinance creating the Commission. The city administration has arbitrarily decided to no longer hold meetings or involve the Commission in the development and operations of the park. It appears this step has again been skipped. The Commission was developed to encourage public involvement. Specifically, the Commission should have reviewed and made recommendations about the proposed lease for the stadium and the update of the Master Development Plan and these planning actions.
3. Mr. Steven Chavez, the LUHO officer, remanded the case back to the EPC, "*The remand must be de novo, reheard anew.*" While the neighbors and I have repeatedly asked questions about the process, city staff has not answered basic questions. Without answers, it has not been possible to prepare for the April 11<sup>th</sup> meeting. Receiving a response in the April 4<sup>th</sup> staff report does not provide adequate to prepare.

Questions:

- a. Are the comments made in the original hearing process part of the record of this "do-over"? How are inaccuracies in the reporting from the original case addressed?
- b. Are the exhibits part of the Remand Hearing included in the new case?
- c. What will be the format for the EPC hearing? Allowing two minutes for people to talk doesn't allow adequate time. I have provided about 60 pages of comments since October 2023. When are questions and comments addressed?

- d. While the lease is not considered part of the EPC review, it is germane to the project. Has the City executed the lease with United New Mexico? At the March 4, 2024, facilitated meeting with the neighbors, Mr. Ron Patel, United New Mexico, stated, "*You know, as a reminder, the lease that we signed with the city.*" Is this true? City staff, the consultants, and United New Mexico have made statements about the project that are not substantiated by the draft lease. As the EPC reviews the proposed master plan amendments, all parties involved must understand the answer to this question.
4. The March 21, 2024, EPC hearing was deferred to April 11th so a study session could be held to refresh EPC Commissioners and staff about cross-examination procedures. Most study sessions are open to the public; however, the EPC indicates this will not be open to the public. The neighborhoods also need to understand the "cross-examination" process. Why is the meeting not open to the public? This leaves the neighbors at a distinct disadvantage. Did planning firms such as Consensus Planning or other City Departments putting forward projects receive an invitation to the meeting?
5. I understand that United New Mexico has conducted meetings at their merchandise shop in Nob Hill to discuss the stadium project. These meetings should not be viewed as public meetings. The affected neighbors and other interested parties were not invited to the gatherings. Meeting at a private business location is not appropriate for a public meeting.

I understand that the team representatives discussed changes to the stadium's design. No one from United New Mexico, city staff, or the consultants have discussed the changes with the neighbors.

The consultants for the project indicated that new sound studies would be done for the project. Has that occurred? If so, why weren't the results shared with the affected neighborhoods?

I understand that a justification should be provided when a deferral is requested regarding an EPC hearing. Hopefully, my letter will be sufficient for a deferral so that these issues and other issues can be addressed. In the March 14, 2024, letter from Jackie Fishman, Consensus Planning, she requested a deferral until April 11<sup>th</sup> with no justification provided. While I am glad the deferral occurred, it makes me question the difference in the process for the neighbors and the public vs a city-sponsored project.

Sincerely,



Sandra Zuschlag  
8105 Irwin ST. NE, ABQ, NM 87109  
[Szuschlag58@gmail.com](mailto:Szuschlag58@gmail.com)  
505-250-3798



**Bolivar, Silvia A.**

---

**From:** Tina Villegas <t-marie-v@hotmail.com>  
**Sent:** Thursday, April 4, 2024 8:03 AM  
**To:** Bolivar, Silvia A.  
**Cc:** Brooke Jordy; hdhauser@comcast.net; Michael Haederle; Sandy Zuschlag; Maggie Rose  
**Subject:** Written Comments -- April 11, 2024 Environmental Planning Commission Meeting  
**Attachments:** 4-11-2024 EPC Hearing Comments - TVillegas.docx

[EXTERNAL] Forward to [phishing@cabq.gov](mailto:phishing@cabq.gov) and delete if an email causes any concern.

Good Morning,

Attached please find my written comments opposing the planned multi-use stadium at Balloon Fiesta Park. I request that they be included as part of the written record.

I also request that the matter be deferred for 90 days due to the fact that the neighborhoods have not been instructed how the cross-examination process will work, how the hearing will be structured and who will be allowed to speak and for how much time, and if any of the previous exhibits and/or comments from the prior hearings will be used or allowed for the new remand hearing.

Thank you for your consideration.

*Tina M. Villegas*

10212 Edith Blvd. NE  
Albuquerque, NM 87113  
505-269-4652



April 4, 2024

**VIA ELECTRONIC MAIL**

Environmental Planning Commission  
City of Albuquerque  
c/o Silvia Bolivar  
[sabolivar@cabq.gov](mailto:sabolivar@cabq.gov)

Subject: Written Comments for the April 11, 2024, EPC Hearing – Proposed Stadium at Balloon Fiesta Park

Dear Ms. Bolivar:

My name is Tina Villegas and I live at 10212 Edith Blvd. NE, Albuquerque, NM 87113, and I am a resident of the North Edith Corridor neighborhood in unincorporated Bernalillo County. I am wholeheartedly opposed to amending the Master Development Plan (MDP) at Balloon Fiesta Park (BFP) that would permit construction of a multi-use stadium at the park.

I have lived in the North Edith Corridor for almost 19 years and my home is only 2,059 feet from the west side of the proposed new stadium. I am most concerned about the noise pollution from the new stadium since New Mexico United (United) is unable to tell us what other events besides soccer will be held at the stadium. Although United has indicated they have improved the stadium design to mitigate noise traveling down to the neighborhoods located to the west, I do not believe they will be able to contain any of the noise unless they put a roof on the stadium. All noise travels down to the lower neighborhoods because I hear most of the events that happen at Balloon Fiesta Park, from the kids practicing soccer, the drones and model airplanes flying around the park, to the larger events such as the Wine Festival, and Freedom 4<sup>th</sup>, to the long 9-days of the Albuquerque International Balloon Fiesta. The sound from the music events and the fireworks often vibrates the windows of my house during events like the Calvary Church Freedom Celebration and the Los Alamos Concert. I have tried contacting the City regarding issues with noise at BFP; however, most times nothing is done.

This is concerning because United keeps telling us that they want to work with the neighborhoods; however, I have only been invited to one meeting held by Consensus Planning and United back in November 2023. A second meeting was held with a mediator on 3/4/2024. United scheduled two additional meetings at their team shop in Nob Hill; however, since I am an appellant in this hearing process, I did not feel comfortable attending without a mediator present. Also, United could not provide the neighborhoods with much information regarding how they would contain the noise

from a stadium of 7,000-10,000 people, and now United indicates it could be 13,000 people. Cheering fans with drums and loud sounding horns. United's own commercials on television indicate they want attendees to "Get Loud". Loud music being played to hype up the crowd, and even the possibility of fireworks. My dogs are very afraid of the fireworks held during the Albuquerque International Balloon Fiesta and I do not wish for them to be further exposed to this type of noise during soccer games. Furthermore, I do not want to pick up the mess left by the firework debris that falls in my yard because I do not want my dogs to think they are chew toys. The local news media also indicates United usually has tailgating events before all games that include bands playing loud music outside of the stadium. Even though United states their games are usually done by 9:00 p.m. my elderly mother-in-law is usually in bed by 7:00 p.m. so why should she be disturbed in her own home by the noise coming from the stadium? I live near several older neighbors who asked me to speak for them that they also do not want their quiet, rural neighborhood disturbed by events held at the stadium.

The stadium will not be in harmony with our neighborhoods which are rural, with small farms, livestock, migratory birds, rabbits, skunks, racoons, and coyotes. The Edith Corridor precedes BFP, and the MDP does not allow for a stadium in the first place.

Also, it would violate provisions of the City of Albuquerque's Integrated Development Ordinance (IDO). The ordinance is meant to "Protect all communities, especially those that have been historically underserved." 1-3(D) and "Protect the quality and character of residential neighborhoods." 1-3(E)

United cannot accurately assess the impact the stadium will have on our neighborhoods in terms of noise. The team's architect said at a meeting with neighbors in March that sound on the field could reach ninety decibels which is more than the sound ordinance allows. Although United indicated they would do another sound study that will measure sound from the proposed stadium area to neighboring houses, that study will not be done until after the EPC has already decided this matter.

Without written assurances from United, how can the neighborhoods understand what types of events will be held at the stadium and how issues with sound will be resolved. United keeps saying they will work with the communities, but we already get that answer from the City which does not help us now, so how can we trust issues will even be investigated once the stadium is built.

United also cannot be sure that light from the stadium will not impact the houses located to the west and northwest. Although United indicates the main lights of the stadium will be positioned as such to project the light downward this may not be enough to keep the light from shining into my upstairs windows at night. What about other lighting outside of the stadium to light walkways and the parking areas? Because

my house sits directly across from the proposed stadium, which is lower than BFP, light pollution could be a factor and once the stadium is built what would be my recourse?

United makes brief mention of a "Community Benefits Program" in the Lease but could not give specifics to the neighborhoods regarding the program when asked at the March 4, 2024, meeting.

A stadium at BFP only benefits the owners of United and would not benefit the surrounding neighborhoods. Instead, it would irreparably affect the property values and causes many more issues for the neighborhoods which the residents do not want or need. Simply put, the neighborhoods do not want a stadium at BFP.

There are several issues which United has not addressed properly regarding the proposed stadium. United keeps stating they will work with the neighborhoods; however, what if issues are not corrected then what recourse will the neighborhoods have once the stadium is built? The EPC is responsible for protecting the residents and property owners from issues such as this and I respectfully request you vote no to amend the MDP at BFP.

Thank you for your time and consideration.

Sincerely,

A handwritten signature in black ink that reads "Tina M. Villegas". The signature is written in a cursive, flowing style.

***Tina M. Villegas***  
10212 Edith Blvd NE  
Albuquerque, NM 87113  
(505) 269-4652

**Bolivar, Silvia A.**

---

**From:** anvanews@aol.com  
**Sent:** Thursday, April 4, 2024 11:11 AM  
**To:** Bolivar, Silvia A.  
**Cc:** swent999@aol.com; anvanews@aol.com  
**Subject:** Letter for the EPC re: 90 day deferral request of Balloon Fiesta Park / NM United Soccer Request Project# PR-2023-009363 (BCC)  
**Attachments:** ANVA BFP S Stadium EPC Deferral ltr 4-4-24.pdf; BFP Soccer Stadium consensus deferral ltr.pdf

[EXTERNAL] Forward to [phishing@cabq.gov](mailto:phishing@cabq.gov) and delete if an email causes any concern.

Ms. Bolivar,

Please find an attached letter for the EPC requesting a 90 day deferral of Balloon Fiesta Park / NM United Soccer Request Project# PR-2023-009363, SI-2023-01635 - Master Development Plan - Major Amendments SI2023-01638 site plan.

The letter is from the Alameda North Valley Association (ANVA); also attached is a letter from Consensus Planning, dated March 14, 2024 that was sent to ANVA.

The letters attached are in a pdf format.

Please feel free to contact me with any questions and **please confirm receipt of the letters.**

Thank you,  
Steve Wentworth  
505-897-3052

**Email:** [anvanews@aol.com](mailto:anvanews@aol.com)

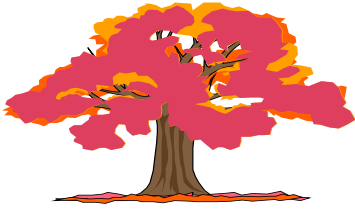

## ALAMEDA NORTH VALLEY ASSOCIATION

8919 Boe Lane NE  
 Albuquerque, NM 87113  
[anvanews@aol.com](mailto:anvanews@aol.com)

Alameda North Valley Association  
 Steve Wentworth, President

April 4, 2024

To: City of Albuquerque Environmental Planning Commission  
 Jonathan R. Hollinger, Chairman

Re: Amendment to the Balloon Fiesta Park Master Development Plan 2012 Update, Site Plan and Variance to IDO

Address: 9201 Balloon Museum Fr. NE, 4900 Balloon Fiesta PKWY NE, and 5601 Alameda NE

**Suggested action by the EPC: The Alameda North Valley Association suggests a ninety (90) day deferral of the hearing for proposed zoning actions and site plan amendments.**

Comments from the Alameda North Valley Association (ANVA):

The EPC Hearing for the above referenced item was due to a remand from the LUHO back to the EPC for notification problems created by the agents and applicants for the use. Once again proper notification did not go out to residents of the area who have been involved with the case and the North Valley Coalition. A copy of a letter sent by Consensus Planning, dated March 14, 2024, lists those who were provided notification about the deferral to April 11, 2024 (attached – pdf). This notification did not go to the many residents who are on the public record as being a party to the case. Not all residents who are a party to the case are members of the listed neighborhood associations and were not notified in a proper manner.

The planning for the stadium and the proposed zone change that will go before the City Council was done without any community input, AIBF input and Balloon Fiesta Park Commission input. Information was only provided after the plans and the zone change application were complete – notification was required by city ordinance – this notification was not by the Mayor’s office wanting to be inclusive. The remand to the EPC by the LUHO indicated a lack of proper notification to the surrounding community by the agents and applicants for the proposed use.

It should be remembered that the surrounding community – business and residential worked with AIBF to purchase the property for the Park, they lobbied the State Legislature for funding and support. The process was very collaborative and a massive gravel pit became a wonderful park for ballooning and youth activities. Neighborhood associations not “recognized by the City” were always included in communication. This is not the case with this proposed project – interested parties and neighborhood groups were left out of the communication processes. We assume that if this case had not been required to follow notification processes dictated by the IDO – the community would not have been notified at all.

Very recently - this past month, United Soccer invited the media to show new plans and proposals they said would address some of the adjacent community's concerns – they said this was one of two public meetings to be held at their offices at Nob Hill. ANVA and other neighbors were not notified about the meetings. If United Soccer wanted to involve the community – notification would be needed for a meeting at a public location near that community like the Balloon Fiesta Park. ANVA and neighbors have not been provided information about the meetings or the proposed changes to the proposed stadium via letters or emails.

United Soccer says over and over they are listening to the concerns of the community – it is hard to determine if they are, due to their lack of communication and collaboration with the community. There is no public way to determine who, if anyone, who they are actually speaking with.

We request a 90 day deferral of the EPC hearing for the proposed zoning actions and site plan amendments.

Respectfully yours,



Steve Wentworth  
President, Alameda North Valley Association

Attached: Consensus Planning letter dated March 14, 2024.

Note: It should be noted that phone calls to City of Albuquerque Planning staff with inquiries about processes and deadlines were not returned.



## REVISED DRAWINGS/RENDERINGS/DETAILS

1. Site Plan, Page 1
2. Building & Structure Elevations, Page 9
3. Building & Structure Elevations, Page 10
4. Contextual Analysis, Page 12
5. Updated West Building Elevation & Site (Rendering)
6. BFP Architectural Details



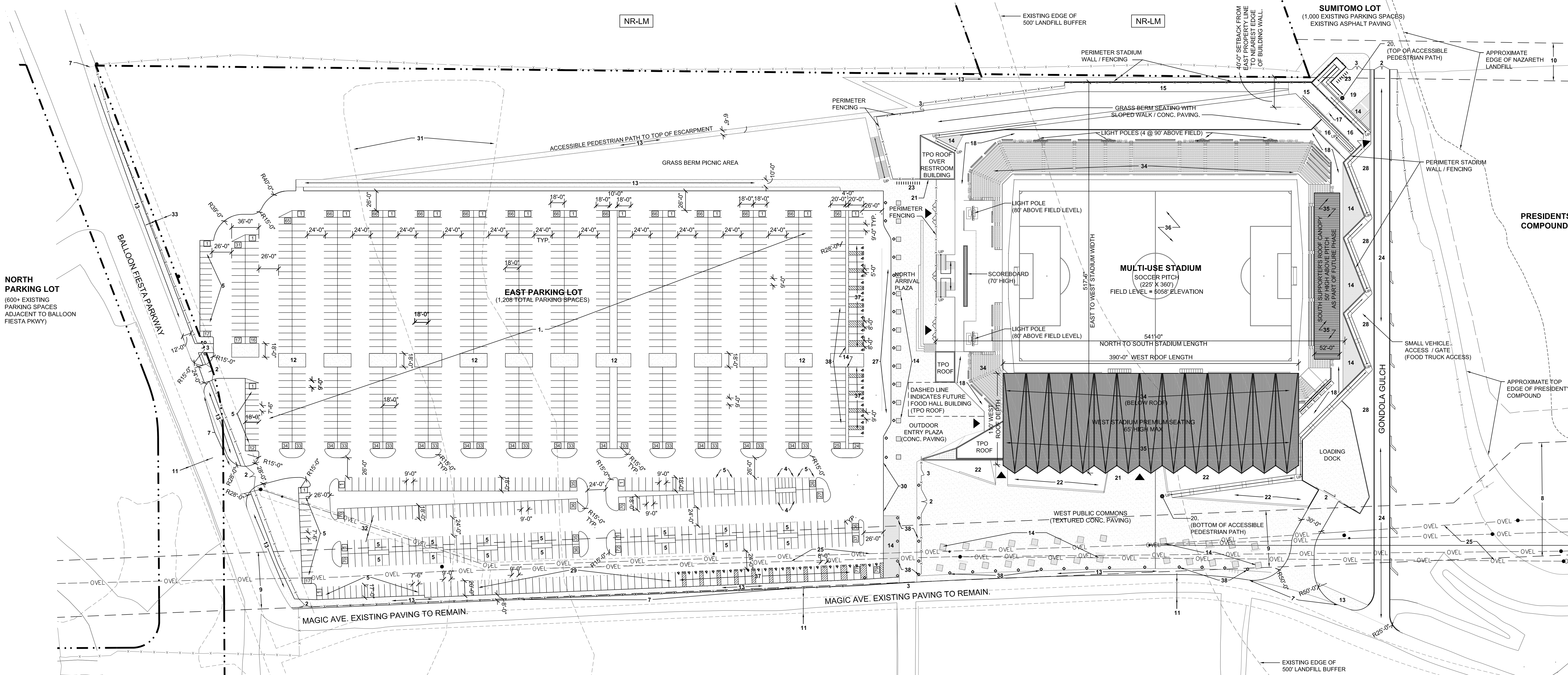

EPC SITE PLAN: MULTI-USE STADIUM AND SITE IMPROVEMENTS

1" = 60'-0"

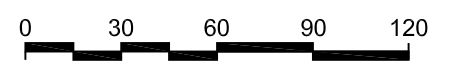

### GENERAL NOTES

- A. TEMPORARY LIGHT POLES ARE TO CONTINUE TO BE USED WITHIN THE EAST LOT DUE TO THE FLEXIBILITY OF YEAR-ROUND USES THE PARKING LOT SERVES AND DUE TO THE SAFETY CONCERNS OF ANY INSTANCES WHERE BALLONS ATTEMPT TO LAND WITHIN THE EAST PARKING LOT. ALL OTHER LIGHTING AROUND THE PERIMETER OF THE STADIUM AND WITHIN ADJACENT PEDESTRIAN PLAZA AREAS SHALL COMPLY WITH THE IDO AND THE MASTER DEVELOPMENT PLAN DESIGN STANDARDS.
- B. SIGNAGE SHALL COMPLY WITH THE APPROVED MASTER DEVELOPMENT PLAN DESIGN STANDARDS FOR THIS SITE. BUILDING SIGNS SHALL NOT EXCEED 20% OF THE FACADE TO WHICH THEY ARE APPLIED. SIGNAGE MAY BE BACK LIT OR LIGHT WITH ACCENT LIGHTING OR INTERNAL LIGHTING, BUT SHALL NOT DIRECT ANY EXCESSIVE LIGHT PROJECTING OUTWARD IN THE DIRECTION OF ANY OF THE SURROUNDING NEIGHBORHOODS.
- C. PAVEMENT MATERIALS WITHIN THE PERIMETER PEDESTRIAN SPACES AROUND THE STADIUM AND IN THE EAST PARKING LOT SHOULD INCLUDE MATERIALS SUCH AS INTEGRAL COLORED AND / OR TEXTURED CONCRETE, BRICK, STONE, OR AGGREGATE CONCRETE, AND SHOULD INCORPORATE PATTERNS AND ARTISTIC DETAILS IN KEEPING WITH THE CHARACTER OF BALLOON FIESTA PARK AND CHARACTER OF THE STADIUM.
- D. ALL SCREENING AND VEGETATION SURROUNDING GROUND-MOUNTED TRANSFORMERS AND UTILITY PADS SHALL ALLOW 10 FEET OF CLEARANCE IN FRONT OF THE EQUIPMENT DOOR AND 5-6 FEET OF CLEARANCE ON THE REMAINING THREE SIDES FOR SAFE OPERATION, MAINTENANCE, AND REPAIR PURPOSES.
- E. PNM COORDINATION: DEVELOPMENT SHALL ABIDE BY ALL CONDITIONS OR TERMS OF UTILITY EASEMENT PRIOR TO DEVELOPMENT. CONTACT SHALL BE MADE TO PNM'S NEW SERVICE DELIVERY DEPARTMENT TO COORDINATE ELECTRIC SERVICE OPTIONS FOR THE LOCATION OF ELECTRIC SERVICE CONNECTION.
- F. ALL SIDEWALKS, RAMPS (INCLUDING REQUIRED TRUNCATED DOMES) CURB CUTS, AND CURB AND GUTTER SHALL BE BUILT PER C.O.A. STANDARD DRAWINGS: SIDEWALK (2430), RAMPS (2440), CURB CUTS (2426), CURB AND GUTTER (2417A), FENCING AND ACCESS. NEW SITE FENCING SHALL BE INSTALLED AROUND THE PERIMETER OF THE STADIUM AND EXISTING CHAIN LINK FENCING WILL BE REMOVED AND REPLACED WITH NEW ALONG MAGIC AVE. AND ALONG PORTIONS OF BALLOON FIESTA PARKWAY AS INDICATED. NEW FENCING INDICATED ALONG BALLOON FIESTA PARKWAY AND PORTIONS OF MAGIC AVE. SHALL BE GALVANIZED OR COATED HEAVY DUTY WIRE MESH PANELS. FENCING ALONG THE PERIMETER OF THE STADIUM SHALL BE A COMBINATION OF WIRE MESH AND PERFORATED METAL PANELS. COLORS SHALL RANGE FROM MEDIUM TO DARK GRAY, WITH ARTISTIC COLOR ACCENTS AT SELECTED AREAS OF FENCING PANELS. NEW CHAIN LINK FENCING WILL PROVIDED AT AREAS CONNECTING TO EXISTING CHAIN LINK FENCING FOR CONSISTENCY.
- H. ALL ADA ACCESSIBLE PARKING SPACES SHALL BE 9' WIDE X 20' DEEP, WITH 5' WIDE ACCESS AISLES AND 8' WIDE VAN ACCESSIBLE AISLES. ALL ADA ACCESS AISLES SHALL HAVE THE WORDS "NO PARKING" IN CAPITAL LETTERS, 12" HIGH AND 2" WIDE, PLACED AT THE BACK OF THE AISLE.
- I. THE FOOD HALL SPACE AND ROOF STRUCTURE AT THE NW CORNER WILL BE CONSTRUCTED AS PART OF A FUTURE PHASE BASED ON FUNDING AVAILABILITY. PHASE 1 WILL INCLUDE: OPEN AIR ENTRY PLAZA, GROUND LEVEL RESTROOMS, TICKETING, SALES, AND ALL VERTICAL CIRCULATION STRUCTURES.

### KEYED NOTES

1. ASPHALT PAVING AND STRIPING PER COA STANDARDS.
2. VEHICULAR ACCESS GATE. SEE TYPICAL ARCHITECTURAL DETAIL.
3. PEDESTRIAN ACCESS GATE. SEE TYPICAL ARCHITECTURAL DETAIL.
4. MOTORCYCLE PARKING SPACES.
5. COMPACT PARKING SPACES, LESS THAN 10% OF TOTAL PARKING IN EAST LOT. (not used)
6. APPROXIMATE BOUNDARY / EXTENTS OF SITE IMPROVEMENTS.
7. EXISTING 150' PNM EASEMENT.
8. PROPOSED PNM EASEMENT (APPROX. 75' WIDE) PER QUITCLAIM ACTION.
9. EXISTING 50' DRAINAGE AND UTILITY EASEMENT.
10. EXISTING 20' COA PUBLIC WATERLINE EASEMENT.
11. TEXTURED CONCRETE PAVING FOR PEDESTRIAN CIRCULATION WITHIN PARKING LOT.
12. CONCRETE SIDEWALK PER COA STANDARDS.
13. CRUSHER FINE PLANTER BEDS FLUSH WITH SURROUNDING PAVING. SEE LANDSCAPE.
14. STADIUM TERRACE. CONCRETE PAVING SYSTEM OVER GRADE.
15. STADIUM TERRACE DECK. CONCRETE PAVERS OVER ROOF MEMBRANE OVER CONCESSIONS SPACE BELOW.
16. HIDDEN LINE INDICATES EDGE OF CONCESSIONS SPACE BELOW.
17. STADIUM MAIN CONCOURSE CIRCULATION LEVEL AT 20' ABOVE FIELD LEVEL.
18. PUBLIC TERRACE / CIRCULATION AREA. C.I.P. CONCRETE PAVING OVER GRADE.
19. ACCESSIBLE PUBLIC CIRCULATION RAMPWAY. PEDESTRIAN PATH CONNECTS TOP OF ESCARPMENT TO LAUNCH FIELD LEVEL ALONG MAGIC AVE. ADA RAMPS @ 1:12 MAX. RAMP WIDTHS ARE 6'-8" WIDE MIN.
20. ACCESSIBLE PUBLIC RESTROOM ACCESS.
21. GRASS BERM LANDSCAPE AREA WITH STEPPED GABION STONE PLANTER AND BUILT-IN BENCHES FOR PICNICKING ALONG THE EDGES OF BERM PERIMETER.
22. ASPHALT PAVING, CURB AND GUTTER PER COA STANDARDS.
23. EXISTING OVERHEAD ELECTRIC LINES.
24. CONCRETE PAVED ACCESS DRIVE INTO LOADING DOCK.
25. CONCRETE PAVED ARRIVAL DROP-OFF LANE.
26. REGRADED LANDSCAPE MATERIAL AREAS.
27. ELECTRIC VEHICLE PARKING SPACE.
28. PROVIDE ROLLED CURB PER COA STANDARDS FOR VEHICULAR ACCESS INTO WEST PLAZA.
29. EXISTING 100' YEAR FLOOD PLAIN.
30. EXISTING 10' PNM & US WEST COMMUNICATIONS EASEMENT.
31. EXISTING 10' US WEST COMMUNICATIONS & COMCAST CABLE EASEMENT.
32. STADIUM SEATING BOWL. ALUMINUM GRANDSTAND STRUCTURE WITH BUILT-IN SEATING. COLORS: GREY, BLACK AND YELLOW.
33. STANDING SEAM METAL ROOF SYSTEM SLOPED TO DRAIN AT 1" PER FOOT AWAY FROM SEATING.
34. SYNTHETIC TURF SOCCER FIELD.
35. ACCESSIBLE PARKING SPACES PER COA STANDARDS. SEE GENERAL NOTES.
36. SYMBOL INDICATES HEAVY DUTY DIE CAST ALUMINUM BOLLARDS. 42" HIGH, 8" DIAMETER, ANODIZED FINISH.

### PROJECT DATA

**SITE INFORMATION**

ZONING: NR-PO-A  
 OVERLAY: NORTH-25 CPO-10

MULTI-USE STADIUM BUILDING AREA: 140,500 SF TOTAL OCCUPIED AREAS AND SEATING BOWL (INCLUDES 54,000 SF ENCLOSED BUILDING FLOOR AREA) (INCLUDES 10,000 SF FOOD HALL IN FUTURE PHASE)

MULTI-USE STADIUM PERIMETER FOOTPRINT INCLUDING SEATING BOWL & SOCCER FIELD: 301,700 SF

IMPROVED EAST PARKING LOT AND ARRIVAL PLAZA AREA: 475,000 SF

WEST PUBLIC COMMONS AREA: 84,000 SF

**OVERALL SITE AREA: 905,000 SF**

**PARKING CALCULATIONS**

STADIUM DESIGN SPECTATOR CAPACITY = 11,000  
 (9,500 SEATING AND DRINK RAIL CAPACITY + 1,400 BERM SEATING AND STANDING ROOM CAPACITY)

PER IDO: 1 PARKING SPACE PER 4 SEATS (11,000 / 4 = 2,750)

REQUIRED PARKING SPACES: 2,750

PROVIDED SPACES: 2,750  
 (1,200 SPACES IN EAST LOT, 1,000 SPACES ON TOP OF ESCARPMENT AT SUMITOMO LOT, 550+ SPACES WITHIN THE NORTH LOT\*)

REQUIRED ACCESSIBLE PARKING: 38  
 PROVIDED ACCESSIBLE PARKING: 40

REQUIRED MOTORCYCLE PARKING: 12  
 PROVIDED MOTORCYCLE SPACES PROVIDED: 12

REQUIRED BICYCLE PARKING: 275  
 PROVIDED BICYCLE PARKING: 275

REQUIRED ELECTRIC VEHICLE PARKING: 138  
 PROVIDED ELECTRIC VEHICLE PARKING: 138\*\*

\* THERE ARE A TOTAL OF 3,335 PARKING SPACES WITHIN THE NORTH LOT AND ADDITIONAL SPACES FOR STADIUM PARKING CAN BE ACCOMMODATED IN THIS AREA AS NEEDED. THE 600 SPACES LISTED ARE THOSE SPACES IMMEDIATELY ADJACENT TO BALLOON FIESTA PARKWAY. THERE ARE A TOTAL OF 9,025 SPACES AVAILABLE WITHIN BALLOON FIESTA PARK OVERALL.

\*\* THERE ARE ZERO ELEC. VEHICLE PARKING SPACES IN THE PARK CURRENTLY. THE TOTAL NUMBER OF REQUIRED ELECTRIC VEHICLE PARKING SPACES WILL BE DISTRIBUTED THROUGHOUT THE ENTIRETY OF THE PARK, A MINIMUM OF 30 EV SPACES CAN BE LOCATED WITHIN THE EAST LOT.

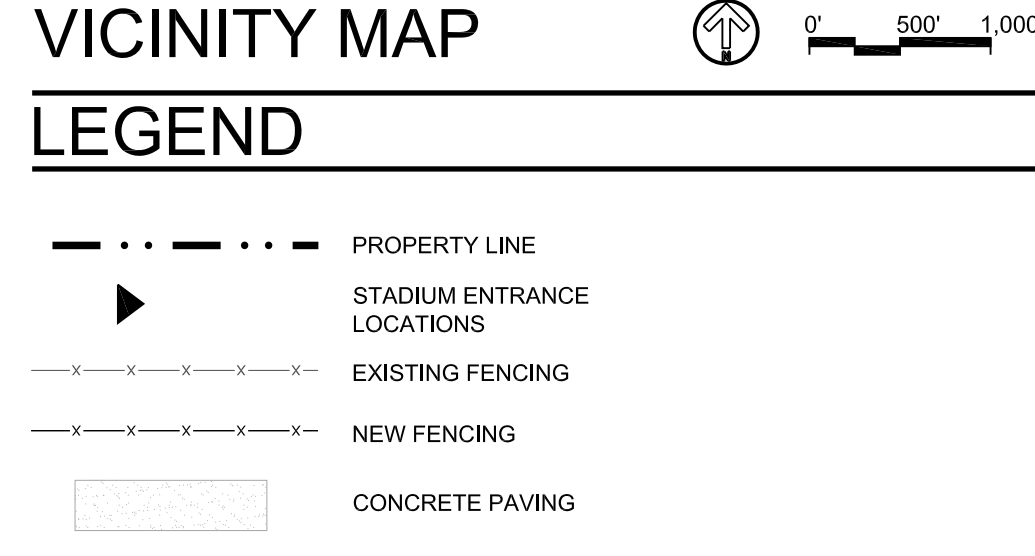
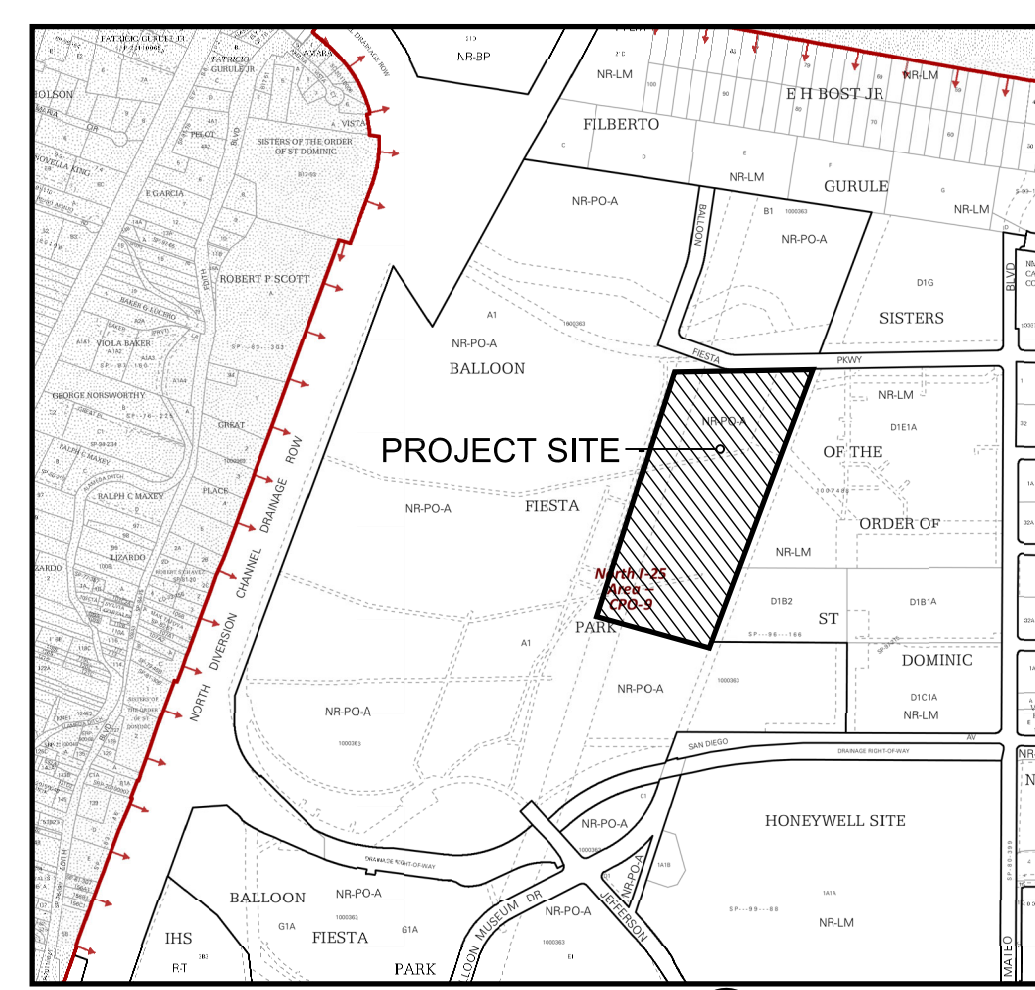

PROJECT NUMBER: 1000363  
 Application Number: \_\_\_\_\_

This plan is consistent with the specific Site Development Plan approved by the Environmental Planning Commission (EPC) dated Month, Date, Year and the Findings and Conditions in the Official Notification of Decision are satisfied.

Is an Infrastructure List required? ( ) Yes ( ) No If yes, then a set of approved DFC plans with a work order is required for any construction within Public Right-of-Way or for construction of public improvements.

DFT SITE DEVELOPMENT PLAN APPROVAL:

Traffic Engineering, Transportation Division

ABCWUA

Parks and Recreation Department

Hydrology

Code Enforcement

\*Environmental Health Department (conditional)

Solid Waste Management

Planning Department



## BALLOON FIESTA PARK MULTI-USE STADIUM

CITY OF ALBUQUERQUE

**PROJECT TEAM**  
 PLANNING/LANDSCAPE ARCHITECTURE  
**CONSENSUS PLANNING**  
 ARCHITECTURE  
 IMPROVE GROUP +  
 ODELL A LABELLA COMPANY  
 ENGINEERING  
 BOHANNAN HUSTON

SITE PLAN - EPC  
 SITE PLAN



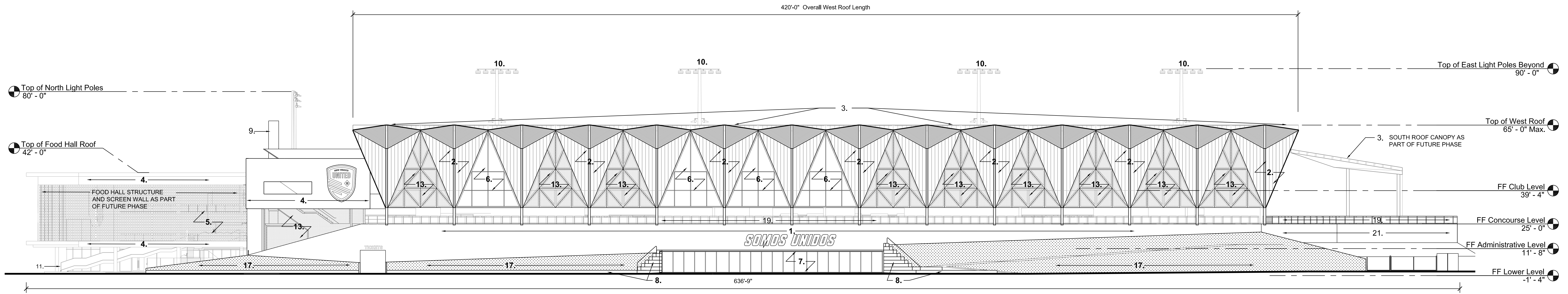

**1 WEST ELEVATION**  
1" = 20'-0"

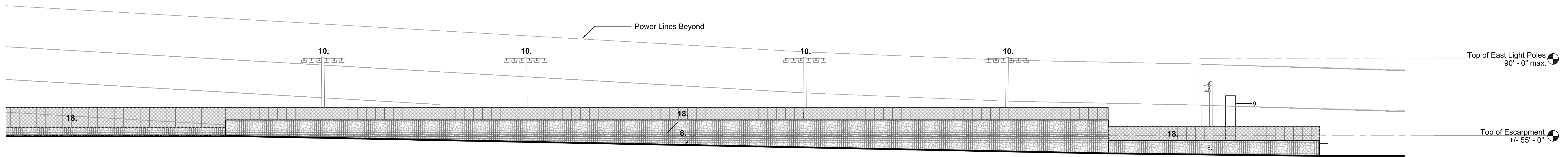
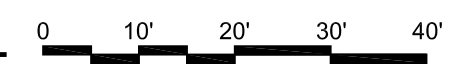

**2 EAST ELEVATION**  
1" = 20'-0"

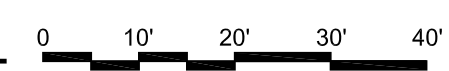

**GENERAL NOTES**

a. Finished floor heights are relative to field level (0'-0") which is equal to elevation 5058'.

**KEYED NOTES**

1. Precast Architectural Concrete Panels. Warm Earth Tone.
2. Aluminum Profile Metal Panel System, Light Gray Tone.
3. Modular Steel Structure with Standing Seam Metal Roof System.
4. Aluminum Composite Metal Panel System. Yellow.
5. Kinetic Aluminum Panel Screen Wall
6. Curtain Wall Glazing System
7. Storefront Glazing System
8. Gabion Wall System
9. Scoreboard
10. Light Poles. See Architectural Details sheet.
11. Monumental Stair, Steel Structure. See Architectural Details sheet.
12. Concrete Steps, Cast in Place with Integral Color
13. Perforated Aluminum metal shade panel system, light grey.
14. Seating Bowl Beyond
15. Pedestrian Concourse Bridge
16. (not used)
17. Grass Berm Picnic Area
18. Perimeter Fence, Heavy-Duty Wire Mesh and Perforated Panels.
19. Metal Guardrail System. Silver
20. Stucco finish system. Warm Grey.
21. Stucco Finish System. Warm Earth Tone.
22. Signage: NM United Shield, see Architectural Details sheet.
23. Signage: Building Sign, see Architectural Details sheet.

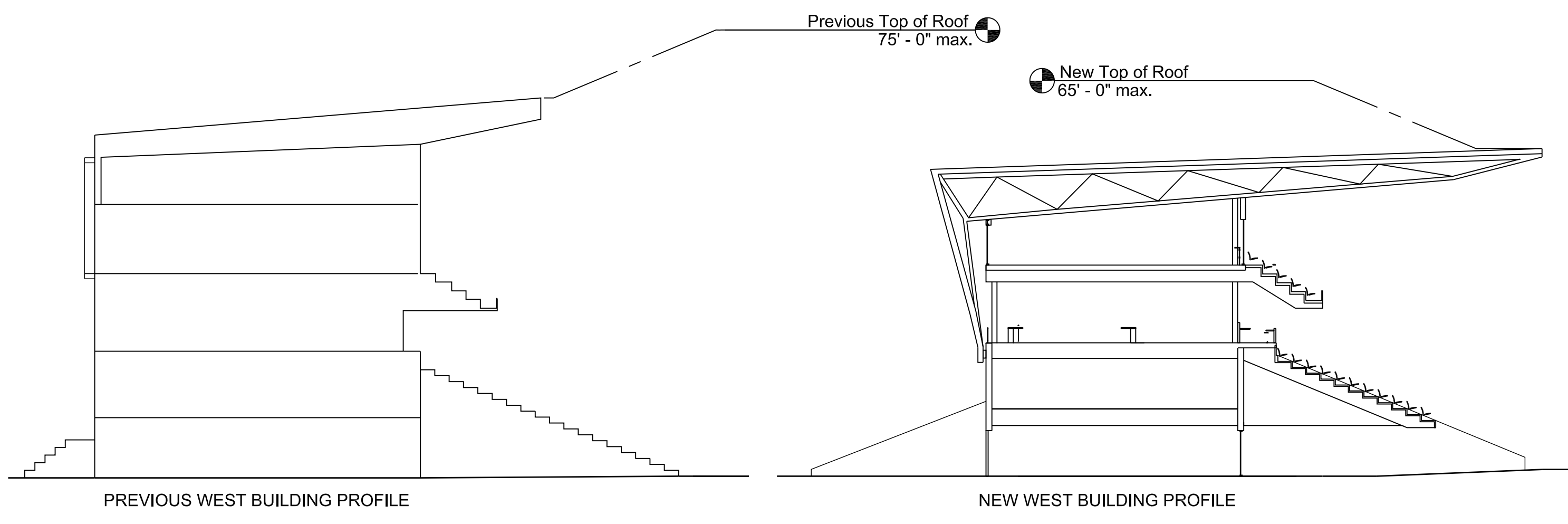

**3 COMPARATIVE DIAGRAM: WEST BUILDING PROFILE / HEIGHT STUDY**  
1" = 20'-0"



**BALLOON FIESTA PARK  
MULTI-USE  
STADIUM**

CITY OF ALBUQUERQUE  
**PROJECT TEAM**  
PLANNING/LANDSCAPE ARCHITECTURE  
CONSENSUS PLANNING  
ARCHITECTURE  
IMPROVE GROUP +  
ODELL A LABELLA COMPANY  
ENGINEERING  
BOHANNAN HUSTON

SITE DEVELOPMENT PLAN FOR BUILDING PERMIT  
**Building and Structure Elevations**

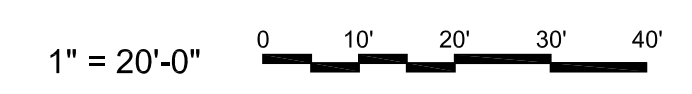

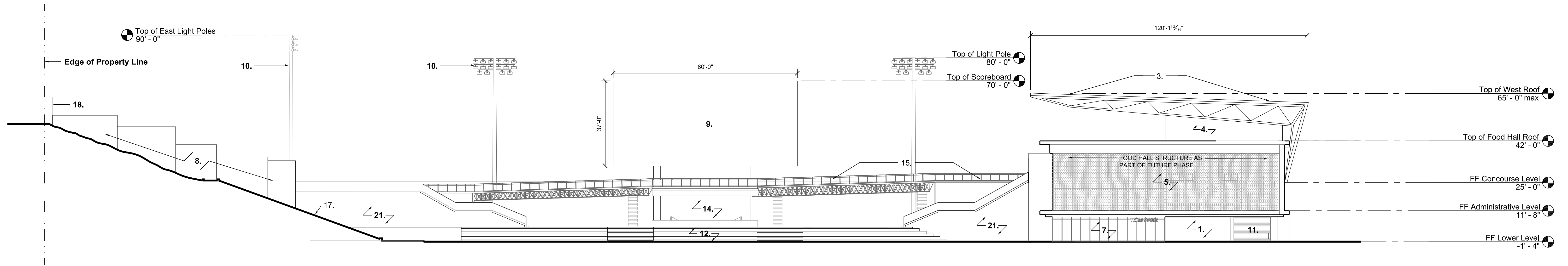

**3 NORTH ELEVATION**  
1" = 20'-0"

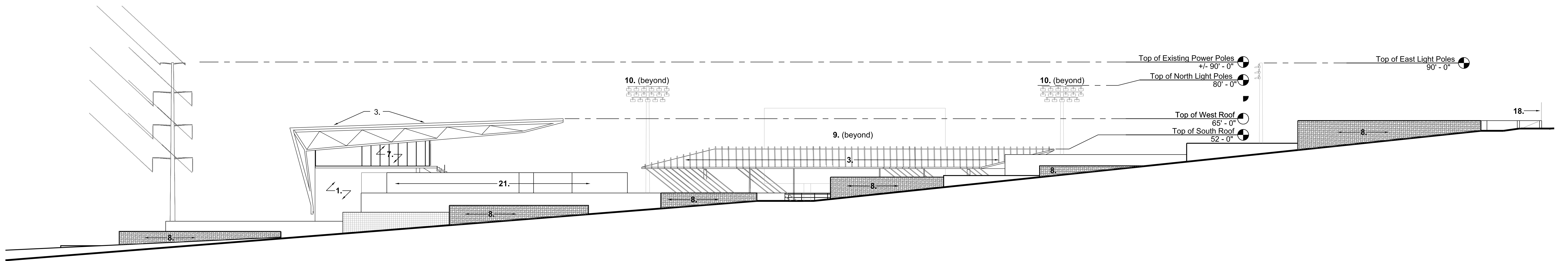

**4 SOUTH ELEVATION**  
1" = 20'-0"

**GENERAL NOTES**

- a. Finished floor heights are relative to field level (0'-0") which is equal to elevation 5058'.

**KEYED NOTES**

1. Precast Architectural Concrete Panels. Warm Earth Tone.
2. Aluminum Profile Metal Panel System, Light Gray Tone.
3. Modular Steel Structure with Standing Seam Metal Roof System.
4. Aluminum Composite Metal Panel System, Yellow.
5. Kinetic Aluminum Panel Screen Wall
6. Curtain Wall Glazing System
7. Storefront Glazing System
8. Gabion Wall System
9. Scoreboard
10. Light Poles. See Architectural Details sheet.
11. Monumental Stair, Steel Structure. See Architectural Details sheet.
12. Concrete Steps, Cast in Place with Integral Color
13. Perforated Aluminum metal shade panel system, light grey.
14. Seating Bowl Beyond
15. Pedestrian Concourse Bridge
16. (not used)
17. Grass Berm Picnic Area
18. Perimeter Fence, Heavy-Duty Wire Mesh and Perforated Panels.
19. Metal Guardrail System, Silver
20. Stucco finish system, Warm Grey.
21. Stucco Finish System, Warm Earth Tone.
22. Signage: NM United Shield, see Architectural Details sheet.
23. Signage: Building Sign, see Architectural Details sheet.



BALLOON FIESTA PARK  
**MULTI-USE STADIUM**

CITY OF ALBUQUERQUE

**PROJECT TEAM**  
PLANNING/LANDSCAPE ARCHITECTURE  
CONSENSUS PLANNING  
ARCHITECTURE  
IMPROVE GROUP +  
ODELL A LABELLA COMPANY  
ENGINEERING  
BOHANNAN HUSTON

SITE DEVELOPMENT PLAN FOR BUILDING PERMIT  
Building and Structure Elevations

1" = 20'-0" 0 10' 20' 30' 40'



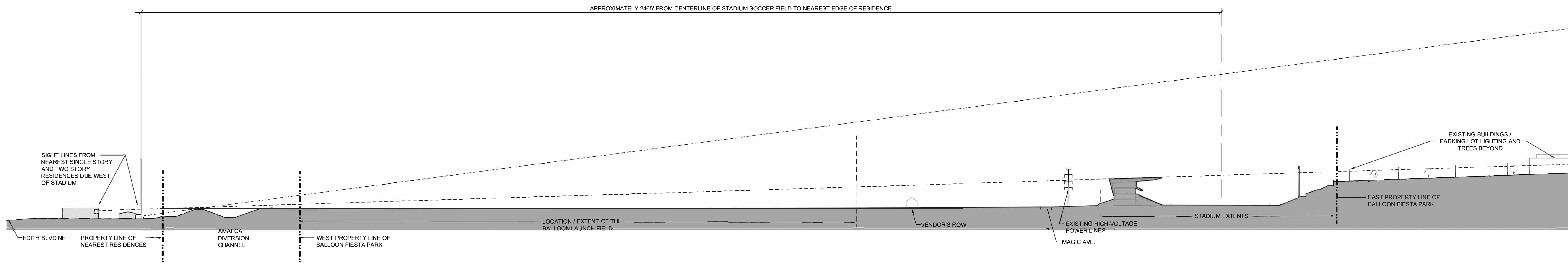

WEST - EAST CROSS SECTION VIEW OF OVER 1/2 MILE FROM EDITH BLVD. TO FAR EAST PARK LIMITS  
1" = 100'-0"



EXISTING SITE CONDITIONS GEOGRAPHIC PROFILE DIAGRAM  
NTS

BALLOON FIESTA PARK  
**MULTI-USE  
STADIUM**

CITY OF ALBUQUERQUE

**PROJECT TEAM**  
PLANNING/LANDSCAPE ARCHITECTURE  
CONSENSUS PLANNING  
ARCHITECTURE  
IMPROVE GROUP +  
ODELL A LABELLA COMPANY  
ENGINEERING  
BOHANNAN HUSTON

SITE DEVELOPMENT PLAN FOR BUILDING PERMIT  
Context Analysis Drawings

1" = 100'-0" 0 100' 200'

SHEET 12 OF 12  
MARCH 6, 2024





UPDATED WEST BUILDING ELEVATION AND SITE

March 13, 2024





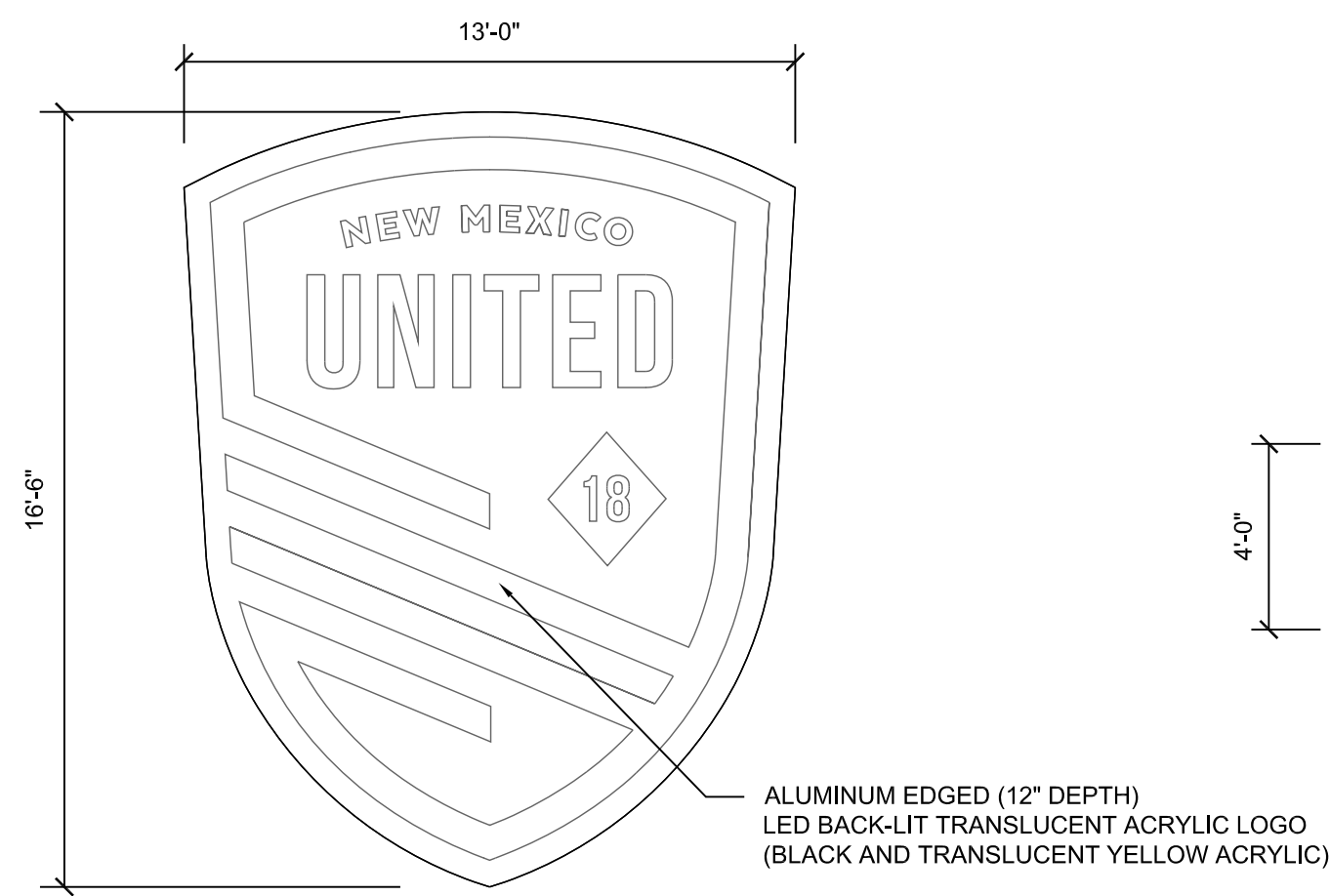

1 UNITED SHIELD SIGNAGE  
1/4" = 1'-0"

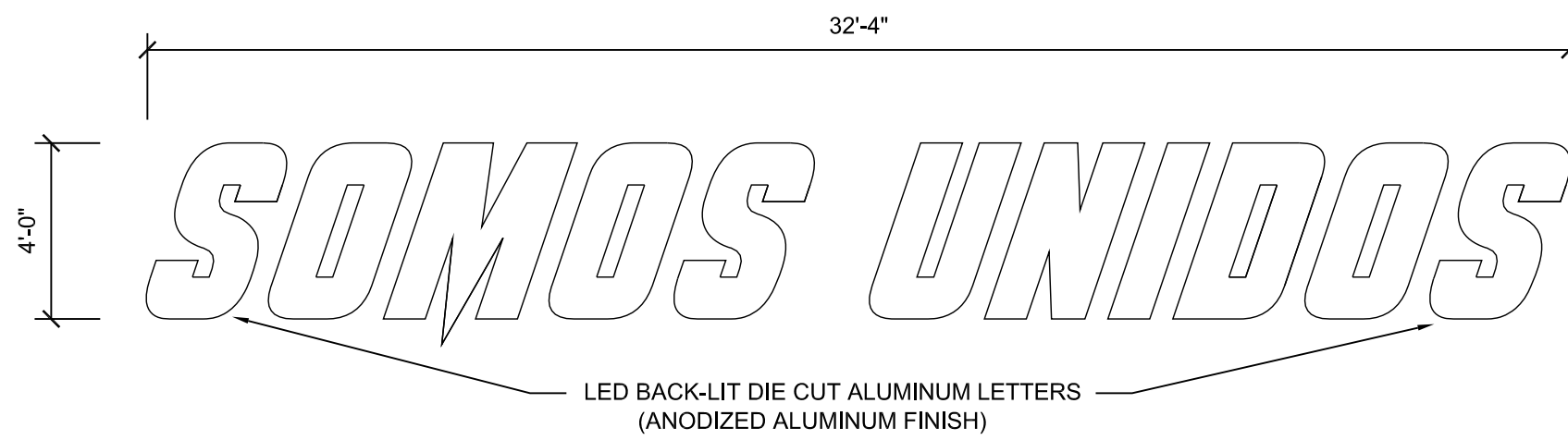

2 WEST STADIUM SIGN  
1/4" = 1'-0"

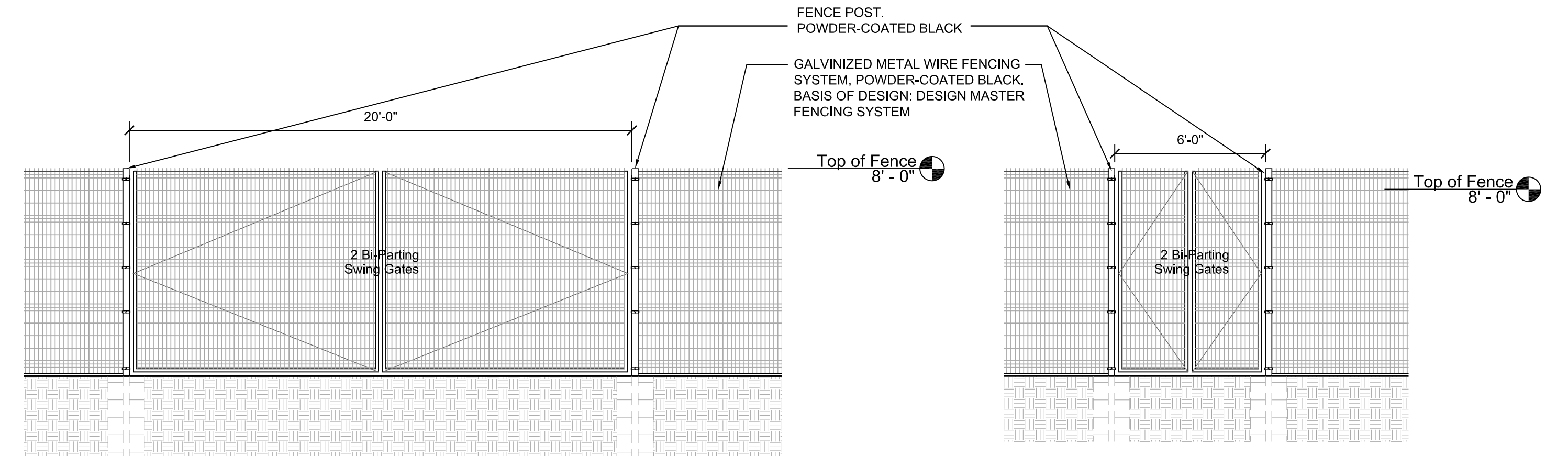

3 TYP. VEHICULAR ACCESS GATE DETAIL  
1/4" = 1'-0"

4 TYP. PEDESTRIAN GATE DETAIL  
1/4" = 1'-0"

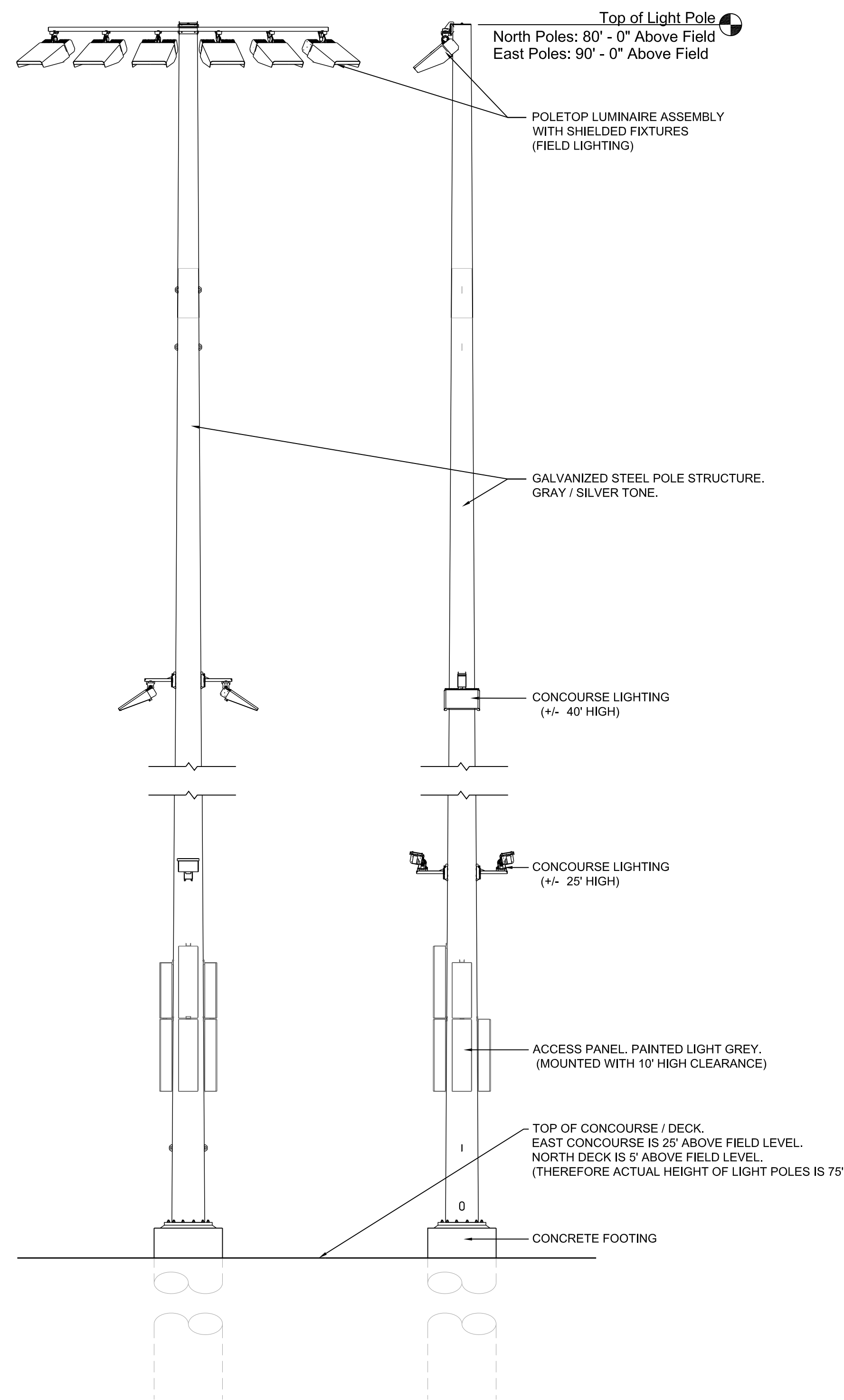

9 LIGHT POLE DETAILS  
1/4" = 1'-0"

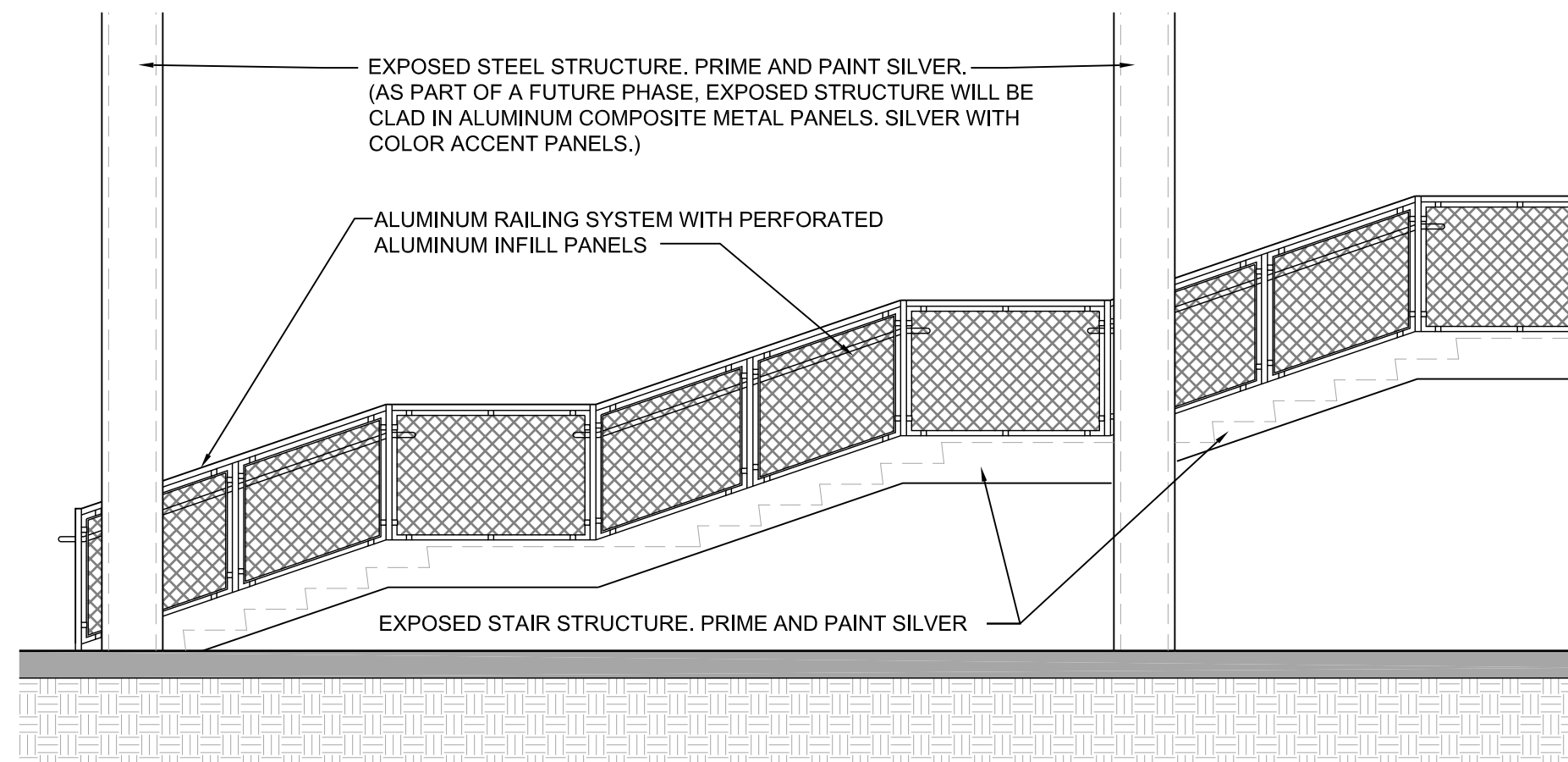

6 ENLARGED MONUMENTAL STAIR ELEVATION  
1/4" = 1'-0"

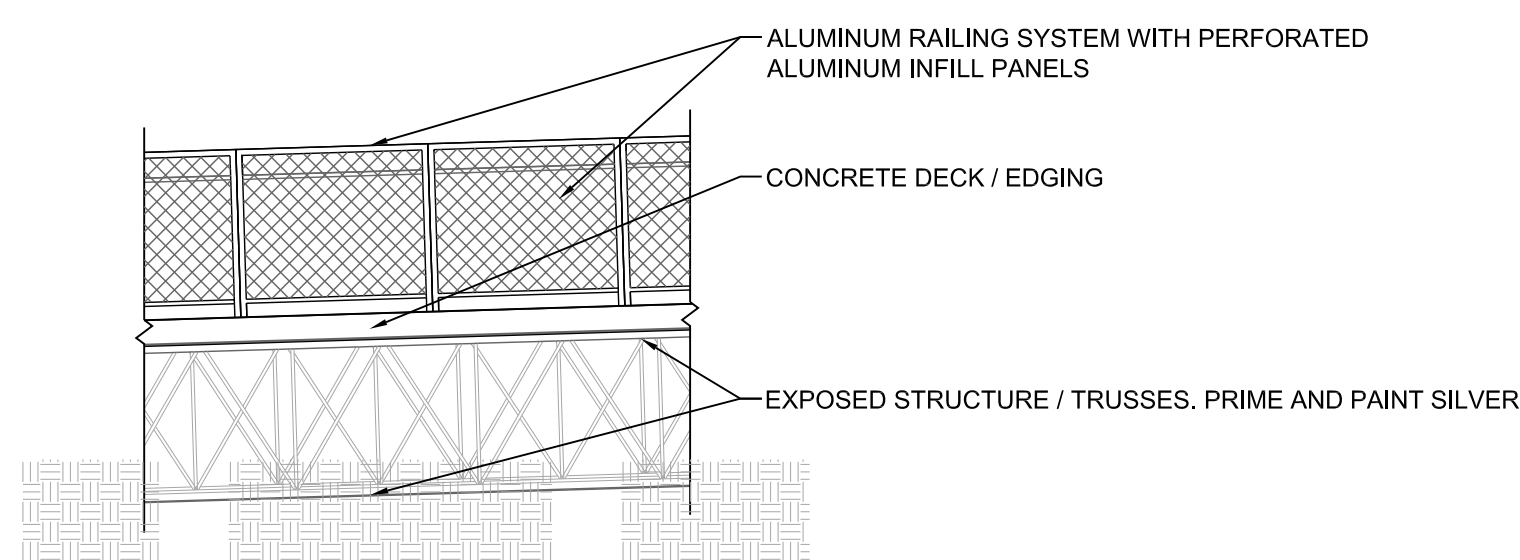

7 NORTH CONCOURSE BRIDGE / TYP. GUARDRAIL DETAIL  
1/4" = 1'-0"

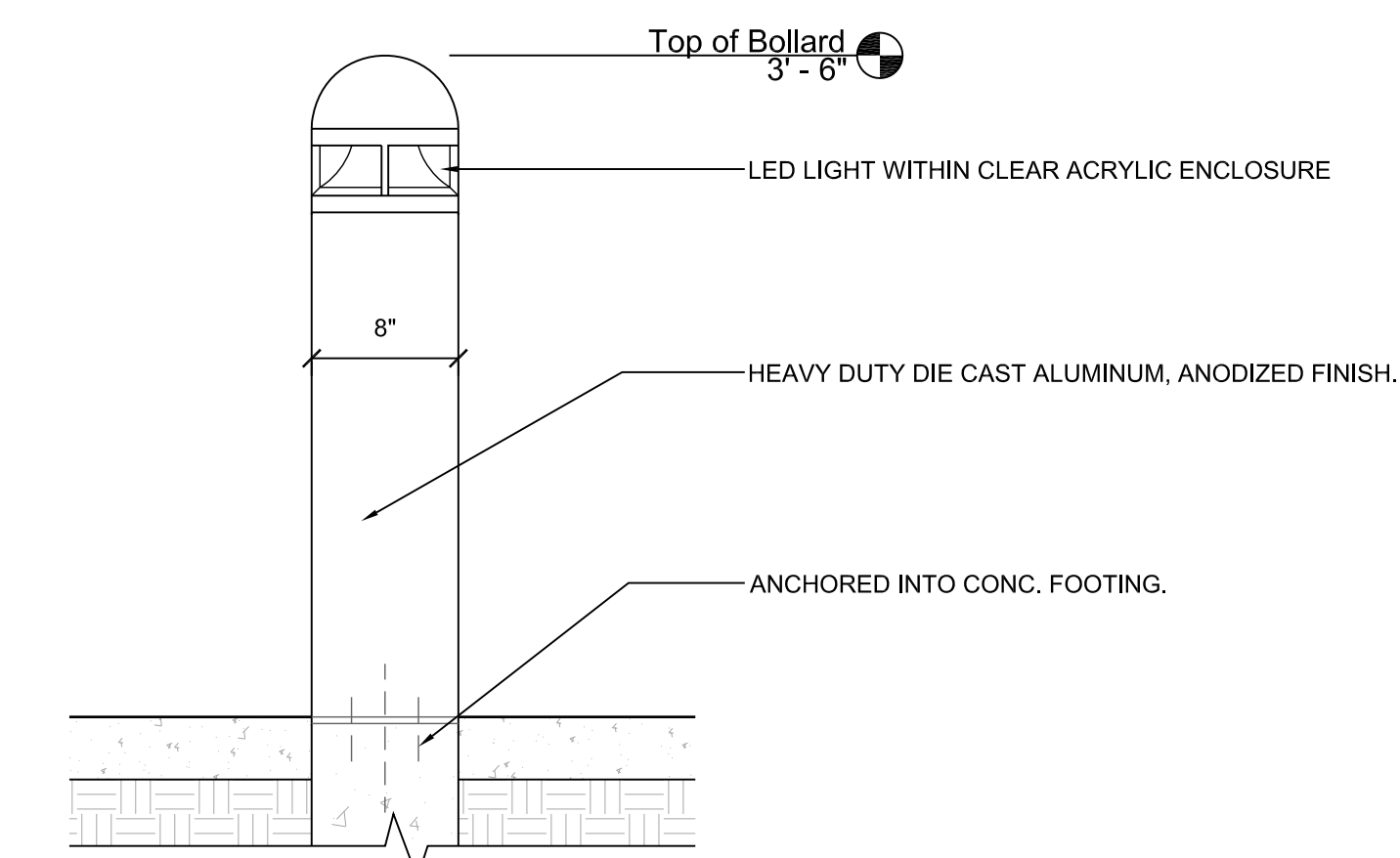

8 LIGHT BOLLARD TYP. DETAIL  
1" = 1'-0"

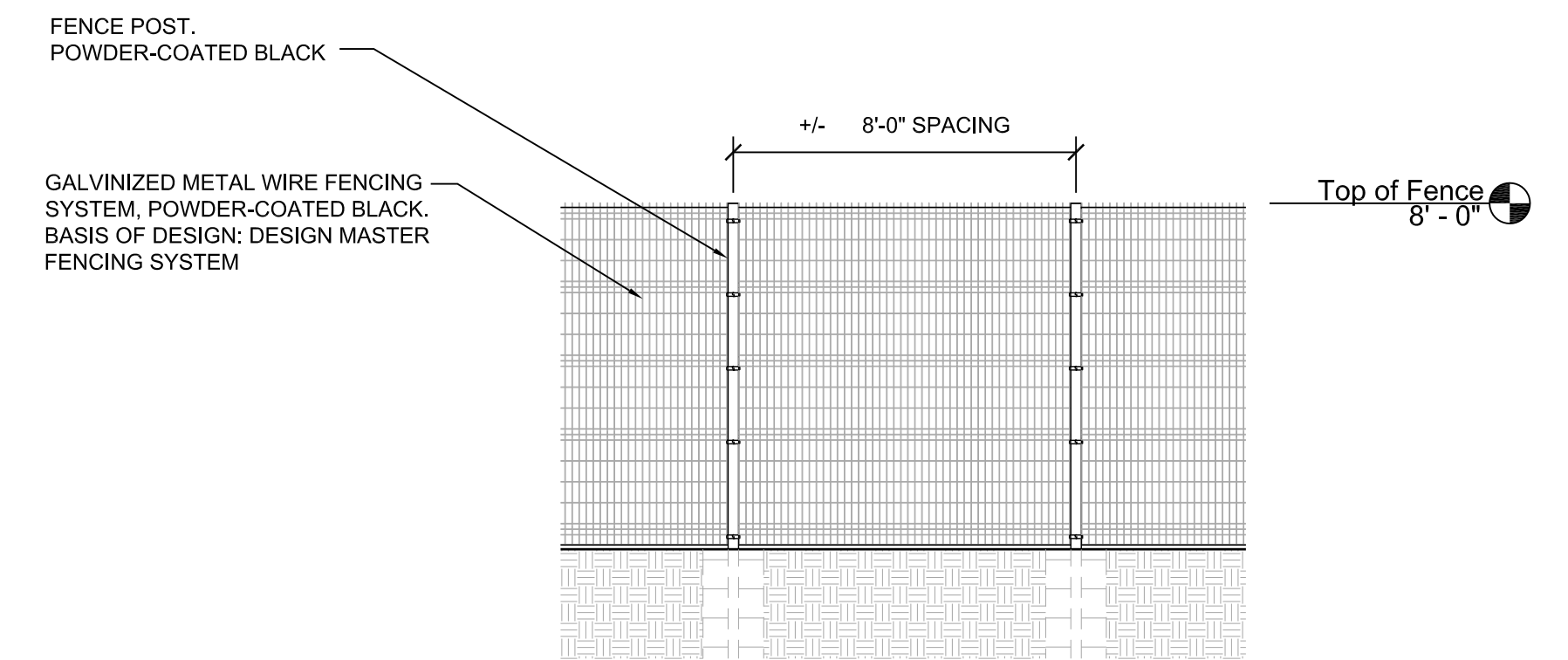

5 TYP. PERIMETER FENCE DETAIL  
1/4" = 1'-0"

BALLOON FIESTA PARK  
**MULTI-USE  
STADIUM**

CITY OF ALBUQUERQUE  
**PROJECT TEAM**  
PLANNING/LANDSCAPE ARCHITECTURE  
CONSENSUS PLANNING  
ARCHITECTURE  
IMPROVE GROUP +  
ODELL A LABELLA COMPANY  
ENGINEERING  
BOHANNAN HUSTON

SITE DEVELOPMENT PLAN FOR BUILDING PERMIT  
Architectural Details