

CHAPTER 7

TRANSPORTATION DESIGN

This chapter presents criteria for the design of street systems and related features to accommodate differing needs. These criteria are intended to assure acceptable levels of comfort, safety, quality, and durability in completed designs.

CONTENTS

ARTICLE 7-1 INTRODUCTION	7-9
ARTICLE 7-2 PURPOSE AND SCOPE	7-9
Part 7-2(A) Governing Policy & Regulations	7-10
Section 7-2(A)(1) Albuquerque/Bernalillo County Comprehensive Plan.....	7-10
Section 7-2(A)(2) Integrated Development Ordinance (Article 14-16 ROA 1994)	
.....	7-10
Section 7-2(A)(3) Drainage Control Ordinance (Part 14-5-2 ROA 1994).....	7-10
Section 7-2(A)(4) Street Tree Ordinance (Part 6-6-2 ROA 1994).....	7-11
Section 7-2(A)(5) Traffic Code (Chapter 8 ROA 1994).....	7-11
Section 7-2(A)(6) Streets and Sidewalks Ordinance (Article 6-5 ROA 1994).	7-11
Section 7-2(A)(7) Long Range Transportation System (LRTS) Guide	7-11
Section 7-2(A)(8) Bikeway & Trails Facility Plan (BTFF).....	7-11
Section 7-2(A)(9) Corridor Studies	7-12
Part 7-2(B) Design Manuals & Resources.....	7-12
Section 7-2(B)(1) Roadway Design	7-12
Section 7-2(B)(2) Pavement Design.....	7-12
Section 7-2(B)(3) Pedestrian Facilities	7-12
Section 7-2(B)(4) Bikeways and Trails.....	7-13
Section 7-2(B)(5) Public Transit.....	7-13
Section 7-2(B)(6) Off-street Parking	7-13
Section 7-2(B)(7) Traffic Calming	7-13
Part 7-2(C) Using the DPM to Determine Roadway Specifications	7-13
Section 7-2(C)(1) Roadway Evaluation Process.....	7-13
Section 7-2(C)(2) Standards versus Guidelines	7-14
Section 7-2(C)(3) Design Waiver.....	7-14
Section 7-2(C)(4) Roadway Evaluation	7-14
Section 7-2(C)(5) Other Design Considerations	7-15
Part 7-2(D) Street Elements	7-17
Section 7-2(D)(1) Pedestrian Realm	7-17
Section 7-2(D)(2) Travel Way.....	7-18
Section 7-2(D)(3) Design Speed	7-20
Section 7-2(D)(4) Street Element Table	7-20

ARTICLE 7-3 ROADWAY DESIGN CONTEXT..... 7-22

Part 7-3(A) Transportation Planning and Policy..... 7-22
 Part 7-3(B) Regional Transportation Planning..... 7-23
 Section 7-3(B)(1) Metropolitan Transportation Plan (MTP)..... 7-23
 Section 7-3(B)(2) Long Range Transportation Systems Guide (LRTS Guide)... 7-25
 Section 7-3(B)(3) Functional Classification 7-27
 Section 7-3(B)(4) Right-of-way Width..... 7-30
 Part 7-3(C) Albuquerque/Bernalillo County Comprehensive Plan 7-31
 Section 7-3(C)(1) General Purpose 7-31
 Section 7-3(C)(2) Implications for the DPM..... 7-32
 Section 7-3(C)(3) ABC Comp Plan Corridors 7-32
 Section 7-3(C)(4) ABC Comp Plan Centers 7-35
 Section 7-3(C)(5) Policy Matrices..... 7-36
 Section 7-3(C)(6) Other Considerations 7-38
 Part 7-3(D) City of Albuquerque Complete Streets Ordinance..... 7-38
 Section 7-3(D)(1) Definition of Complete Streets..... 7-38
 Section 7-3(D)(2) Purpose of Ordinance..... 7-38
 Section 7-3(D)(3) Street Design and Implementation..... 7-39
 Section 7-3(D)(4) Connection Between the Complete Streets Ordinance and the
 DPM..... 7-39
 Part 7-3(E) Principles of Network Design and Roadway Connectivity..... 7-39
 Section 7-3(E)(1) Connectivity 7-40
 Section 7-3(E)(2) Regional Connectivity and Spacing of Major Roads..... 7-41
 Section 7-3(E)(3) Neighborhood Connectivity..... 7-41
 Section 7-3(E)(4) Intersection Density..... 7-42
 Section 7-3(E)(5) Regional Network Considerations..... 7-43

ARTICLE 7-4 DESIGN STANDARDS..... 7-44

Part 7-4(A) Network Connectivity..... 7-44
 Section 7-4(A)(1) Purpose 7-44
 Section 7-4(A)(2) Definition of Terms..... 7-44
 Section 7-4(A)(3) Connectivity..... 7-45
 Section 7-4(A)(4) General Network Considerations..... 7-47
 Section 7-4(A)(5) Block Lengths..... 7-48
 Section 7-4(A)(6) Traffic Signal Spacing 7-48
 Section 7-4(A)(7) Designated Pedestrian Crossings..... 7-50
 Part 7-4(B) Site Access Points..... 7-53
 Section 7-4(B)(1) Definitions 7-53
 Section 7-4(B)(2) General Guidance & Curb Cuts 7-54
 Section 7-4(B)(3) Pedestrian Access..... 7-54
 Section 7-4(B)(4) Vehicular Access..... 7-55
 Section 7-4(B)(5) Curb Return Design 7-58
 Section 7-4(B)(6) Access Control 7-60
 Section 7-4(B)(7) Striping and Signage..... 7-61
 Section 7-4(B)(8) Roadways in NMDOT Jurisdiction..... 7-61
 Part 7-4(C) Pavement Design..... 7-62
 Section 7-4(C)(1) General Provisions..... 7-62
 Section 7-4(C)(2) Subgrade Materials Evaluation..... 7-62
 Section 7-4(C)(3) Traffic Factors in Pavement Design..... 7-64
 Section 7-4(C)(4) Structural Design of Pavement..... 7-67
 Section 7-4(C)(5) Flexible Pavements Design 7-69
 Section 7-4(C)(6) Portland Cement Concrete Design..... 7-71
 Section 7-4(C)(7) Alternative Pavement 7-71

Part 7-4(D) Curb and Gutter	7-72
Section 7-4(D)(1) Right-of-way Requirements.....	7-72
Section 7-4(D)(2) Private Property Requirements.....	7-72
Part 7-4(E) Pedestrian Facilities.....	7-72
Section 7-4(E)(1) Public Sidewalks.....	7-73
Section 7-4(E)(2) Pedestrian Walkways.....	7-83
Part 7-4(F) Bikeways and Trails.....	7-84
Section 7-4(F)(1) General Provisions	7-84
Section 7-4(F)(2) Locations of Future Facilities.....	7-84
Section 7-4(F)(3) Bicycle Lanes	7-84
Section 7-4(F)(4) Bicycle Routes.....	7-86
Section 7-4(F)(5) Bicycle Boulevards.....	7-87
Section 7-4(F)(6) Paved Trails.....	7-87
Section 7-4(F)(7) Trail Alternatives.....	7-90
Part 7-4(G) Public Transit.....	7-91
Section 7-4(G)(1) General Provisions.....	7-91
Section 7-4(G)(2) Pedestrian Connections.....	7-91
Section 7-4(G)(3) Boarding and Alighting Areas.....	7-92
Section 7-4(G)(4) Transit Stop and Station Types.....	7-93
Section 7-4(G)(5) Roadway Design Considerations for Transit in Mixed Flow Traffic	7-96
Section 7-4(G)(6) Dedicated Transit Infrastructure.....	7-98
Part 7-4(H) On-street Parking.....	7-100
Section 7-4(H)(1) General Provisions.....	7-100
Section 7-4(H)(2) Design Guidance	7-102
Section 7-4(H)(3) Maintenance and Parking Agreements.....	7-105
Section 7-4(H)(4) Creation of New On-street Parking During Development	7-106
Section 7-4(H)(5) Parklets	7-106
Part 7-4(I) Geometric Design Criteria.....	7-107
Section 7-4(I)(1) General Design Criteria.....	7-108
Section 7-4(I)(2) Horizontal Alignment.....	7-108
Section 7-4(I)(3) Superelevation	7-109
Section 7-4(I)(4) Vertical Alignment.....	7-110
Section 7-4(I)(5) Sight Distance	7-111
Section 7-4(I)(6) Intersection Design.....	7-115
Section 7-4(I)(7) Median and Turn Lane Design.....	7-121
Part 7-4(J) Local Streets.....	7-130
Section 7-4(J)(1) Local Street Classifications.....	7-130
Section 7-4(J)(2) Local Street Design	7-131
Section 7-4(J)(3) Stub, Cul-de-sac, and Loop Street Criteria.....	7-134
Section 7-4(J)(4) Emergency Service Access to Local Streets.....	7-135
Section 7-4(J)(5) Private Streets.....	7-136
Section 7-4(J)(6) Private Ways.....	7-136
Section 7-4(J)(7) Entrance and Gate Requirements for Private Ways and Streets	7-137
Part 7-4(K) Off-street Parking and Site Design	7-137
Section 7-4(K)(1) General Provisions.....	7-137
Section 7-4(K)(2) Bicycle Parking.....	7-137
Section 7-4(K)(3) Motorcycle Parking.....	7-138
Section 7-4(K)(4) Standard and Small Car Parking.....	7-139
Section 7-4(K)(5) ADA Accessible Parking.....	7-140
Section 7-4(K)(6) Angled Parking.....	7-141
Section 7-4(K)(7) Off-street Loading Spaces.....	7-142
Section 7-4(K)(8) Pavement of Parking Areas.....	7-142

Section 7-4(K)(9) Curbing in Parking Areas.....	7-142
Section 7-4(K)(10) Grading in Parking Areas.....	7-142
Section 7-4(K)(11) Sidewalk Connections.....	7-143
Section 7-4(K)(12) Site Access.....	7-143
Section 7-4(K)(13) Fire and Emergency Access.....	7-143
Section 7-4(K)(14) Solid Waste Access.....	7-143
Section 7-4(K)(15) Access Throat Length and Queuing.....	7-144
Section 7-4(K)(16) Site Layout and Circulation.....	7-144
Section 7-4(K)(17) Parking Islands.....	7-145
Section 7-4(K)(18) Service Areas.....	7-146
Section 7-4(K)(19) Signage & Striping.....	7-146
Section 7-4(K)(20) Drive-through Facilities.....	7-146
Section 7-4(K)(21) Layout of Large Parking Areas.....	7-146
Section 7-4(K)(22) Traffic Circulation Layout (TCL).....	7-147
Part 7-4(L) Traffic Calming.....	7-147
Section 7-4(L)(1) Neighborhood Traffic Calming.....	7-147
Section 7-4(L)(2) Speed Management on Major Roads.....	7-147
Part 7-4(M) Street Lighting.....	7-149
Section 7-4(M)(1) Roadway Lighting Criteria.....	7-149
Section 7-4(M)(2) New Lighting System Considerations.....	7-151
Section 7-4(M)(3) Distribution Criteria.....	7-151
Section 7-4(M)(4) Correlated Color Temperature (CCT).....	7-151
Section 7-4(M)(5) Luminaire Criteria.....	7-152
Section 7-4(M)(6) Street Lighting Development Build out Requirements.....	7-153
Part 7-4(N) Traffic Control and Development Requirements.....	7-154
Section 7-4(N)(1) Traffic Control & Phasing Plan.....	7-154
Section 7-4(N)(2) Traffic Construction and Fees.....	7-155
Part 7-4(O) Naming Streets.....	7-155
Section 7-4(O)(1) Method of Naming.....	7-155
Section 7-4(O)(2) Street Designations.....	7-155
Section 7-4(O)(3) Street Names.....	7-156
Section 7-4(O)(4) Procedure.....	7-156
Section 7-4(O)(5) Markings.....	7-156
Section 7-4(O)(6) Signage.....	7-156
Section 7-4(O)(7) Traffic Signals.....	7-156
Section 7-4(O)(8) Barricades at Ends of Pavements Signage.....	7-157

ARTICLE 7-5 TRAFFIC STUDIES.....7-158

Part 7-5(A) Background and Purpose.....	7-158
Part 7-5(B) Traffic Scoping Form and Traffic Impact Study.....	7-159
Section 7-5(B)(1) Traffic Scoping Form (TSF).....	7-159
Section 7-5(B)(2) Traffic Impact Study (TIS).....	7-159
Part 7-5(C) Traffic Study Warranting Criteria.....	7-160
Section 7-5(C)(1) TSF Warranting Criteria.....	7-161
Section 7-5(C)(2) TIS Warranting Criteria.....	7-162
Part 7-5(D) Traffic Analysis Procedures.....	7-162
Section 7-5(D)(1) Traffic Scoping Form.....	7-162
Section 7-5(D)(2) Traffic Impact Study (TIS).....	7-163
Part 7-5(E) TIS Report Elements.....	7-164
Section 7-5(E)(1) Executive Summary.....	7-164
Section 7-5(E)(2) Introduction.....	7-164
Section 7-5(E)(3) Existing Conditions.....	7-165
Section 7-5(E)(4) Future Traffic Conditions and Analysis Years.....	7-166

Section 7-5(E)(5) Proposed Site Traffic Characteristics 7-167
 Section 7-5(E)(6) Traffic Analysis..... 7-169
 Section 7-5(E)(7) Site Access Requirements..... 7-170
 Section 7-5(E)(8) Summary of Findings 7-170
 Section 7-5(E)(9) Recommendations & Mitigation Measures..... 7-171
 Part 7-5(F) Neighborhood Impact Assessment (NIA)..... 7-172
 Section 7-5(F)(1) NIA Purpose/Scope 7-173
 Section 7-5(F)(2) NIA Minimum Requirements..... 7-173

ARTICLE 7-6 DEFINITIONS7-174

TABLES

TABLE 7.2.27 Roadway Evaluation Process 7-15
 TABLE 7.2.28 Automobile LOS by Corridor and Location* 7-16
 TABLE 7.2.29 Street Element Dimensions..... 7-21
 TABLE 7.3.30 Planning Document and Relevance for DPM 7-23
 TABLE 7.3.31 Applications of the LRTS Guide in the DPM..... 7-26
 TABLE 7.3.32 LRRS Roadway Types..... 7-27
 TABLE 7.3.33 Roadway Functional Classification Descriptions..... 7-29
 TABLE 7.3.34 Right-of-way Width Ranges for Major Roads 7-31
 TABLE 7.3.35 Right-of-way Width Ranges for Local Roads..... 7-31
 TABLE 7.3.36 Relationship among Corridor Types 7-33
 TABLE 7.3.37 ABC Comp Plan Corridor Designations 7-34
 TABLE 7.3.38 ABC Comp Plan Center Types and Definitions..... 7-35
 TABLE 7.3.39 ABC Comp Plan Matrices – Descriptions and Relevance to DPM
 7-37
 TABLE 7.3.40 Intersection Density by Location, LRTS Guide 7-42
 TABLE 7.4.41 Characteristics by Location 7-46
 TABLE 7.4.42 Recommended Distance between Signalized Intersections by
 Corridor Type 7-49
 TABLE 7.4.43 Designated Pedestrian Crossing Types..... 7-52
 TABLE 7.4.44 Low-density Residential Driveways..... 7-55
 TABLE 7.4.45 Minimum Distance Between Commercial Site Access and
 Intersection 7-58
 TABLE 7.4.46 Maximum Number of Commercial Site Access Points per Site
 7-58
 TABLE 7.4.47 Driveway Widths for Arterial, Collector, and Local Streets 7-59
 TABLE 7.4.48 Curb Return Radii by Design Vehicle – Single Entrance/Exit
 Widths..... 7-60
 TABLE 7.4.49 R-value and Resilient Modules (M_r) Correlation 7-64
 TABLE 7.4.50 Traffic Criteria for Pavement Design..... 7-65
 TABLE 7.4.51 Growth Factor* 7-65
 TABLE 7.4.52 ESAL Vehicle Equivalency Factor 7-66
 TABLE 7.4.53 Lane Distribution Factor, DL..... 7-66
 TABLE 7.4.54 Minimum Pavement Component Thickness 7-67
 TABLE 7.4.55 Structural Coefficients of Pavement Components..... 7-67
 TABLE 7.4.56 Serviceability Rating* 7-68
 TABLE 7.4.57 Reliability and Statistical Values 7-68
 TABLE 7.4.58 Standard Normal Deviation Values..... 7-69
 TABLE 7.4.59 Structural Design Computation Form 7-70

TABLE 7.4.60	Dimensions for Angle Parking.....	7-102
TABLE 7.4.61	Minimum Parallel Parking Stall Width by Speed Limit.....	7-103
TABLE 7.4.62	Minimum Centerline Radius for a Normal Road*	7-109
TABLE 7.4.63	Design Controls for Vertical Curves	7-111
TABLE 7.4.64	Minimum Stopping Sight Distance.....	7-112
TABLE 7.4.65	Minimum Intersection Sight Distance	7-114
TABLE 7.4.66	Curb Return Radii Table.....	7-120
TABLE 7.4.67	Turn Lane Warrants.....	7-125
TABLE 7.4.68	Right-turn Lane Design Criteria.....	7-126
TABLE 7.4.69	Taper Design Criteria.....	7-127
TABLE 7.4.70	Minimum Left-turn Lane Transition Length.....	7-127
TABLE 7.4.71	ADT Parameters for Local Streets.....	7-130
TABLE 7.4.72	ADT Generation for Local Streets.....	7-131
TABLE 7.4.73	Local Street Design Standards.....	7-132
TABLE 7.4.74	Maximum Cul-de-sac Length.....	7-134
TABLE 7.4.75	Private Way Design Standards.....	7-136
TABLE 7.4.76	Easement Radii for Private Access Easements	7-136
TABLE 7.4.77	Parking Stall Dimensions.....	7-139
TABLE 7.4.78	Dimensions for Standard Angle Parking.....	7-141
TABLE 7.4.79	Dimensions for Compact Angle Parking.....	7-141
TABLE 7.4.80	Off-street Loading Space Dimensions	7-142
TABLE 7.4.81	Minimum Throat Length.....	7-144
TABLE 7.4.82	Minimum Drive Aisle Width.....	7-145
TABLE 7.4.83	Minimum Average Maintained Illuminance. E_h	7-150
TABLE 7.4.84	Minimum Average Maintained Illuminance.....	7-150
TABLE 7.4.85	Illuminance Method - Recommended Values.....	7-150
TABLE 7.4.86	Allowable CCT and Duv.....	7-152
TABLE 7.5.87	Traffic Analysis Requirements by Location	7-161
TABLE 7.5.88	Desired LOS by Location and Corridor Type.....	7-165
TABLE 7.5.89	LOS for Main Street Corridors.....	7-165

FIGURES

FIGURE 7.2.41	Street Element Dimensions Along Major Roads.....	7-21
FIGURE 7.3.42	Transportation and Land Use Planning	7-22
FIGURE 7.3.43	Access and Functional Class	7-27
FIGURE 7.3.44	Pedestrian Access to Cul-de-sac Example.....	7-40
FIGURE 7.3.45	Layered Networks.....	7-43
FIGURE 7.4.46	Regional and Neighborhood Roadway Networks.....	7-44
FIGURE 7.4.47	Controlled Pedestrian Crossing Example	7-45
FIGURE 7.4.48	Uncontrolled Pedestrian Crossing Example.....	7-45
FIGURE 7.4.49	Neighborhood Connectivity	7-47
FIGURE 7.4.50	Example Layout: Signalized Intersections & Pedestrian Crossings	7-49
FIGURE 7.4.51	Pedestrian Crossing Examples.....	7-52
FIGURE 7.4.52	Pedestrian Crossing Decision Path.....	7-53
FIGURE 7.4.53	Site Access Elements.....	7-54
FIGURE 7.4.54	Right-of-way Dedication.....	7-55
FIGURE 7.4.55	Low-density Residential Driveway Location and Dimensions	7-56
FIGURE 7.4.56	Driveway Distance From Intersection.....	7-56
FIGURE 7.4.57	Low-density Residential Shared Access Point	7-57
FIGURE 7.4.58	Commercial Site Access Points and Distance From Intersection	7-58
FIGURE 7.4.59	Curb Return Access Point.....	7-59
FIGURE 7.4.60	Divided Entrance Width.....	7-60
FIGURE 7.4.61	Non-residential Driveways with Aligned Centerline.....	7-61
FIGURE 7.4.62	Design Chart Flexible Pavements	7-70
FIGURE 7.4.63	Residential Area	7-74
FIGURE 7.4.64	Mixed-use Area.....	7-74
FIGURE 7.4.65	Sidewalk Slopes.....	7-75
FIGURE 7.4.66	Pedestrian Access Route.....	7-76
FIGURE 7.4.67	Perpendicular Curb Ramp	7-77
FIGURE 7.4.68	Parallel Curb Ramp	7-78
FIGURE 7.4.69	Directional Curb Ramp	7-78
FIGURE 7.4.70	Curb Ramp Counter Slope	7-79
FIGURE 7.4.71	Curb Ramp Clear Space.....	7-80
FIGURE 7.4.72	Crosswalk Marking.....	7-81
FIGURE 7.4.73	Refuge Island – At Grade.....	7-82
FIGURE 7.4.74	Refuge Island – Raised Median.....	7-83
FIGURE 7.4.75	Bicycle Lane.....	7-85
FIGURE 7.4.76	Paved Trail.....	7-88
FIGURE 7.4.77	Blended Transition Ramp with Matching Trail and Ramp Width	7-89
FIGURE 7.4.78	Trail Alternative 1, Vertical Separation.....	7-90
FIGURE 7.4.79	Trail Alternative 2, Trail in Lieu of Sidewalk.....	7-91
FIGURE 7.4.80	Transit Boarding and Alighting	7-92
FIGURE 7.4.81	ADA/PROWAG-compliant Pedestrian Access Route	7-93
FIGURE 7.4.82	ADA/PROWAG-compliant Bench Design Requirements.....	7-94
FIGURE 7.4.83	Travel Lane.....	7-96
FIGURE 7.4.84	Bus Turnout.....	7-97
FIGURE 7.4.85	Bus Bay.....	7-98

FIGURE 7.4.86 Median Transit Lanes and Center Platform Station 7-100

FIGURE 7.4.87 Dimensions for Angle Parking 7-102

FIGURE 7.4.88 Parallel Parking Dimensions 7-104

FIGURE 7.4.89 Bicycle Parking Corral Examples 7-105

FIGURE 7.4.90 Parklet Location and Examples 7-107

FIGURE 7.4.91 Example Superelevation Runout Plan 7-109

FIGURE 7.4.92 Stopping Sight Distance 7-112

FIGURE 7.4.93 Intersection Sight Distance
..... 7-114

FIGURE 7.4.94 Mini Clear Sight Triangle 7-115

FIGURE 7.4.95 Standard Curb Return Radii Diagram 7-119

FIGURE 7.4.96 Effective Curb Return Radii Diagram
..... 7-120

FIGURE 7.4.97 Median with Center Turn Lane
..... 7-122

FIGURE 7.4.98 Median Opening Spacing
..... 7-123

FIGURE 7.4.99 Turn Lane Design Elements 7-125

FIGURE 7.4.100 Right-turn Lane Design Elements
..... 7-126

FIGURE 7.4.101 Right Taper Design Elements 7-126

FIGURE 7.4.102 Right-in / Right-out 7-127

FIGURE 7.4.103 Right-in / Right-out and Left-in 7-128

FIGURE 7.4.104 Right-in / Right-out and Left-out 7-128

FIGURE 7.4.105 Restricted Median: Left-in Only 7-128

FIGURE 7.4.106 Restricted Median: Left-in and Left-out on One Side 7-128

FIGURE 7.4.107 Restricted Median: Left-in Both Sides 7-129

FIGURE 7.4.108 Two-way Left-turn Lane 7-129

FIGURE 7.4.109 Local Street Classification 7-131

FIGURE 7.4.110 Typical Access Local and Normal Local Street Cross Section
..... 7-133

FIGURE 7.4.111 Major Local Street Cross Section with Designated Parking.. 7-133

FIGURE 7.4.112 Major Local Street Cross Section with bicycle Lanes 7-133

FIGURE 7.4.113 Cul-de-sac Dimensions 7-134

FIGURE 7.4.114 Hammerhead Dimensions 7-135

FIGURE 7.4.115 Bicycle Parking Stall Layout Options 7-138

FIGURE 7.4.116 Parking Stall Dimensions 7-139

FIGURE 7.4.117 ADA Accessible Parking Stall and Access Aisle Dimensions 7-140

FIGURE 7.4.118 Dimensions for Angle Parking 7-141

FIGURE 7.4.119 Site Access Design 7-143

FIGURE 7.4.120 Throat Length 7-144

FIGURE 7.4.121 Keyway in Parking Area 7-145

FIGURE 7.4.122 Parking Islands 7-146

ARTICLE 7-1 INTRODUCTION

Transportation in an urban environment is a complex interaction of different modes of travel, trip purposes, and land use contexts. This chapter presents criteria established for use in the design of street systems and related features to accommodate these differing needs. These criteria are intended to ensure acceptable levels of comfort, safety, quality, and durability in completed transportation projects.

The guidance and regulations provided in the transportation chapter of the DPM are intended for use by qualified design professionals familiar with municipal street design. A brief overview of important governing regulations is presented together with references to commonly-accepted design manuals and publications related to the subject. Designers and others using this manual are expected to familiarize themselves fully with the pertinent regulations and the publications cited in the DPM.

The infrastructure standards contained in the DPM are intended to provide public benefits and support the health, welfare, and safety of Albuquerque residents. While the use of minimum design standards is generally cost effective, there are operational benefits and reduced economic life cycle costs when design exceeds the minimum required standard. The design values in this chapter represent the minimum standard; however, the project designer is encouraged to use values above this minimum.

ARTICLE 7-2 PURPOSE AND SCOPE

The transportation chapter of the DPM establishes standards and guidance both for private developers during the creation of site development and master plans, and the City of Albuquerque for the design of new roadways or reconstruction and rehabilitation of existing roadways. The purpose of this chapter is to promote consistently sound design of street systems with acceptable performance characteristics, to encourage innovative design, and to assert the need for sound, responsible, professional judgment by the designer.

Standards and guidelines established by this document rely on best practices from national design manuals and standards used by similar sized municipalities. This chapter was also developed in coordination with the [Albuquerque/Bernalillo County Comprehensive Plan \(ABC Comp Plan\)](#) and the [Integrated Development Ordinance \(IDO\)](#) to ensure that land use and transportation strategies work together within the City of Albuquerque. The linkages between applicable policy and regulatory documents that inform infrastructure standards contained in the transportation chapter are further described in [Article 7-3 Roadway Design Context](#). This chapter also provides step-by-step guidance in the roadway design process to help designers correctly apply DPM standards when designing facilities within the City.

Part 7-2(A) Governing Policy & Regulations

Following are overviews of important City and regional policy and regulatory documents pertaining to street design. The list is not intended to be exhaustive, and the user is cautioned that these regulations are subject to change at any time. The DPM ensures that street design standards are consistent with the following ordinances and regulations. Nevertheless, competent designers must maintain familiarity with these and other pertinent regulations as they are updated over time.

Section 7-2(A)(1) Albuquerque/Bernalillo County Comprehensive Plan

The [ABC Comp Plan](#) contains a shared community vision for how the City of Albuquerque and Bernalillo County should grow and confront long-term challenges as well as the cultural and environmental features that should be protected in the future. As a policy document, the [ABC Comp Plan](#) contains guidance about where growth is appropriate and what form it should take, including Center and Corridor designations and policy matrices. Additional information on the relationship between the [ABC Comp Plan](#) and the DPM is provided in [Article 7-3 Roadway Design Context](#).

Section 7-2(A)(2) Integrated Development Ordinance (Article 14-16 ROA 1994)

The [Integrated Development Ordinance \(IDO\) \(Article 14-16 ROA 1994\)](#) contains regulations relating to access, circulation, and parking on private property; the interface with City right-of-way; and maximum block length and size. The [IDO](#) establishes zoning and land use categories that, in turn, govern certain street design parameters.

[IDO Section 14-16-5-4 \(Subdivision of Land\)](#) includes the following topics that are particularly relevant to street design:

- *Requirements for Traffic Engineer approval of any plat that creates City right-of-way and private access easements.*
- *General right-of-way standards for streets, based upon roadway classification.*
- *Requirements for the provision of and compliance with detailed design criteria and technical standards for construction in the DPM.*

Section 7-2(A)(3) Drainage Control Ordinance (Part 14-5-2 ROA 1994)

The [Drainage Control Ordinance \(Part 14-5-2 ROA 1994\)](#) establishes requirements governing design of storm runoff facilities as such facilities relate to the street system. The Drainage Ordinance also requires at least 1 all-weather access to developments.

Section 7-2(A)(4) **Street Tree Ordinance (Part 6-6-2 ROA 1994)**

[Part 6-6-2 Street Tree Ordinance \(ROA 1994\)](#) requires the installation of trees along major streets when obtaining building permits or paving parking lots.

Section 7-2(A)(5) **Traffic Code (Chapter 8 ROA 1994)**

The [Traffic Code \(Chapter 8 ROA 1994\)](#) regulates general traffic control, enforcement of construction signing, and establishes the criteria for clear-sight geometry at intersections.

Section 7-2(A)(6) **Streets and Sidewalks Ordinance (Article 6-5 ROA 1994)**

The [Streets and Sidewalks Ordinance \(Article 6-5 ROA 1994\)](#) contains the following guidance and requirements:

- **Street Names:** Establishes consistent criteria for use in naming City streets and streets within the extraterritorial planning and platting jurisdiction of the City.
- **Future Street Lines:** Provides for establishment of future street lines by the City Council. The Ordinance prohibits the construction of buildings and substantial alterations and additions to existing structures within such designated future street lines and setback areas.
- **Sidewalks:** Establishes the requirement for the construction of sidewalk and curb and gutter for properties, including dimensional, location, and construction regulations for sidewalks.
- **Curb Cuts:** Regulates the location, dimensions, and placement of driveway entrances through curbs to public rights-of-way.
- **Complete Streets:** Provides direction to the City to evaluate all design projects and incorporate all modes of transportation when designing or rehabilitating streets. See the Roadway Design Context section for additional information.

Section 7-2(A)(7) **Long Range Transportation System (LRTS) Guide**

The [LRTS Guide](#) is part of the [Metropolitan Transportation Plan \(MTP\)](#) contains maps depicting the long-range transportation networks through the Albuquerque urban area, as developed by the Mid-Region Council of Governments (MRCOG)/Mid-Region Metropolitan Planning Organization (MRMPO) and adopted by the Metropolitan Transportation Board (MTB). (See [Article 7-3 Roadway Design Context](#) for additional information.)

1. **Long Range Roadway System (LRRS):** Guides the locations and right-of-way set-aside for major streets.
2. **Long Range Bicycle System (LRBS):** Depicts the current and future bikeway systems for the region.

Section 7-2(A)(8) **Bikeway & Trails Facility Plan (BTFP)**

The [Bikeway and Trails Facility Plan \(BTFP\)](#) provides direction for the City in development of a well-connected, enjoyable, and safe bicycle and trail

network. Many of the design guidelines and standards from the [BTFP](#) are incorporated into this chapter.

Section 7-2(A)(9) Corridor Studies

Corridor studies take place regularly throughout the city, and such studies may influence design of major streets. The City's [Engineering Division](#) of the Department of Municipal Development should be consulted for detailed information.

Part 7-2(B) Design Manuals & Resources

The following design manuals and other resources provide regulations and guidance for designing and building transportation infrastructure. The list is not intended to be exhaustive, and the user is cautioned that these regulations are subject to change at any time.

These documents may be updated over time. The DPM is consistent with the most updated versions as of 2018, with publication years indicated below. Designers should always use or reference the most recent version.

Section 7-2(B)(1) Roadway Design

1. American Association of State Highway and Transportation Officials (AASHTO), [A Policy on Geometric Design of Highways and Streets \(AASHTO Green Book\)](#), 6th edition, 2011.
2. AASHTO, [Roadside Design Guide](#), 2011.
3. Federal Highway Administration (FHWA), [Manual on Uniform Traffic Control Devices \(MUTCD\)](#), 2009.
4. Institute for Transportation Engineers (ITE), [Designing Walkable Urban Thoroughfares](#), 2010.
5. National Association of City Transportation Officials (NACTO), [Urban Street Design Guide](#), 2013.
6. Transportation Research Board (TRB), [Highway Capacity Manual \(HCM\)](#), 2010.

Section 7-2(B)(2) Pavement Design

1. AASHTO, [Guide for Design of Pavement Structures](#), 1993.
2. AASHTO, [Supplement to the AASHTO Guide for Design of Pavement Structures. Part II-Rigid Pavement Design and Rigid Pavement Joint Design](#), 1998.
3. City of Albuquerque, [Standard Specifications for Public Works Construction \(City Standard Specifications\)](#), Section 2400.

Section 7-2(B)(3) Pedestrian Facilities

1. City of Albuquerque, [IDO Subsection 14-16-5-6\(C\), \(General Landscaping Standards\)](#), 2018.
2. City of Albuquerque, [IDO Subsection 14-16-5-6\(D\) \(Street Frontage Landscaping\)](#), 2018.
3. City of Albuquerque, [Part 6-6-2 Street Tree Ordinance \(ROA 1994\)](#), 2015.

4. City of Albuquerque, [DPM Part. 6-13\(A\) Low Impact Development \(LID\) Strategies](#), 2017.
5. U.S. Access Board, [Americans with Disabilities Act Accessibility Guidelines \(ADA\)](#), 2004.
6. U.S. Access Board, [Americans with Disabilities Act Final Guidelines for Outdoor Developed Areas](#), 2013.
7. U.S. Access Board, [Public Rights of Way Accessibility Guidelines \(PROWAG\)](#), 2013.

Section 7-2(B)(4) Bikeways and Trails

1. AASHTO, [Guide for the Development of Bicycle Facilities](#), 2012.
2. City of Albuquerque, [BTFP](#), 2015.
3. FHWA, [MUTCD](#), 2009.
4. MRCOG, [LRBS](#).
5. NACTO, [Urban Bikeway Design Guide](#), 2014.
6. U.S. Access Board, [ADA](#), 2004.

Section 7-2(B)(5) Public Transit

1. AASHTO, [Guide for the Geometric Design of Transit Facilities on Highways and Streets](#), 2014.
2. American Public Transportation Association (APTA), [Designing Bus Rapid Transit Running Ways](#), 2010 version.
3. NACTO, [Transit Street Design Guide](#), 2016.
4. Transit Cooperative Research Program (TCRP) Report 90, [Bus Rapid Transit, Volume 2: Implementation Guidelines](#), 2003.
5. U.S. Access Board, [ADA](#), 2004.
6. U.S. Access Board, [PROWAG](#), 2013.

Section 7-2(B)(6) Off-street Parking

1. City of Albuquerque, [Chapter 8 Traffic Code \(ROA 1994\)](#).
2. City of San Francisco, [San Francisco Parklet Manual](#), 2018.
3. FHWA, [MUTCD](#), 2009.

Section 7-2(B)(7) Traffic Calming

1. City of Albuquerque, [Neighborhood Traffic Management Program \(NTMP\)](#), 2015.

Part 7-2(C) Using the DPM to Determine Roadway Specifications

Section 7-2(C)(1) Roadway Evaluation Process

Designers should follow a series of steps to determine the appropriate range in right-of-way and street design standards when considering the design of a new roadway or rehabilitation or reconstruction of an existing facility. [TABLE 7.2.27](#) below and the [DPM Part 7-2\(C\)](#) assist designers and users through the roadway evaluation process to ensure relevant policies and design standards are considered.

Roadway design guidance in the DPM is generally based on 3 designations:

1. **ABC Comp Plan Corridor:** City-specific designations reflecting the intended urban design and priority modes and street elements for major roadways.
2. **Functional Classification:** Designations defined by the Federal Highway Administration regarding the role of the roadway in moving people and goods.
3. **Design Speed:** The actual speed motorists are intended to travel under free-flow traffic conditions. Design speed is a function of roadway geometry. Some technical and geometric standards for roadways vary depending on the design speed rather than the roadway type. General guidance on design speeds are provided by Corridor type and functional classification in [ABC Comp Plan Table 7-5: Priority Street Element Matrix](#). (See [Part 7-2\(D\) Street Elements](#).)

Additional information on functional classification and Corridor designations are provided in the [Roadway Design Process](#) section.

Section 7-2(C)(2) Standards versus Guidelines

The DPM contains a combination of requirements and recommendations for transportation infrastructure. In instances where the term “shall” is used, the design information constitutes a standard where implementation is mandatory. If the term “should” is used, the design information constitutes a guideline and designers are encouraged to apply the guidelines to the greatest extent feasible.

Section 7-2(C)(3) Design Waiver

Where deviations from the DPM are necessary due to topographical, right-of-way, or other constraints, a design waiver may be requested from the City Engineer. The waiver process is described in [Chapter 2 Development Procedures](#).

Section 7-2(C)(4) Roadway Evaluation

[TABLE 7.2.27](#) outlines the process a designer should follow when designing a roadway and choosing necessary roadway elements and suitable dimensions. Standards for desired roadway elements are contained throughout this chapter of the DPM.

TABLE 7.2.27 Roadway Evaluation Process

Step	Actions Required by Roadway Designer
<p>1. Consult the Long Range Roadway System</p>	<p>Determine functional classification and right-of-way ranges.</p> <p>If the roadway is classified as a principal arterial, determine whether the corridor is a regional principal arterial or a community principal arterial on the LRRS (right-of-way needs vary depending on the regional role of the principal arterial).</p> <p>Identify existing right-of-way.</p>
<p>2. Consult the ABC Comp Plan Center and Corridors Network map</p>	<p>Determine relevant <u>land use designation</u>, including whether the roadway passes through transit station areas or identified Centers that have special guidance.</p> <p>Identify the <u>Corridor type</u>. The Corridor designation provides guidance on priorities by travel mode and other design characteristics.</p> <p>Check for references to the roadway on the LRBS, Bikeways and Facilities Trails Plan, MTP Priority Transit Network, and MTP Primary Freight Network.</p>
<p>3. Review the ABC Comp Plan Priority Street Element Matrix</p>	<p>Determine which modes of transportation and street design elements should be prioritized, depending on any applicable Center or Corridor designations.</p>
<p>4. Review Existing Conditions</p>	<p>Analysis should determine if changes to the configuration of the roadway are desired. Considerations include: roadway configuration, travel conditions, traffic volume, alternative mode infrastructure and transit service, landscaping and sidewalk width, and medians and turn lanes.</p>
<p>5. Design / Redesign</p>	<p>Complete roadway design to support intended roadway users and surrounding land use context. This may vary along the roadway corridor.</p>

Section 7-2(C)(5) Other Design Considerations

7-2(C)(5)(i) ADA/PROWAG

All new streets shall be constructed in compliance with ADA/PROWAG standards. During reconstruction projects, designers shall make every effort to ensure the street is brought into compliance with ADA/PROWAG. Where PROWAG standards conflict with ADA standards, the ADA standards shall prevail.

7-2(C)(5)(ii) Design Vehicle

The design vehicle to be used in the roadway design and redesign process shall be an SU-30. Where high levels of heavy truck travel are anticipated, an alternative design vehicle may be used with approval by the City Engineer. See the [Section 7-4\(I\)\(6\) Intersection Design](#) and [Part 7-4\(B\) Site Access Points](#) for guidance on curb return radii and other design elements where consideration of the design vehicle is required.

7-2(C)(5)(iii) Level of Service (LOS)

7-2(C)(5)(iii)(a) Automobile LOS

The [ABC Comp Plan](#) establishes appropriate LOS by location. Per the [ABC Comp Plan](#), automobile mobility needs are to be balanced against the needs of other roadway users. Lower LOS, and somewhat higher levels of congestion associated with lower LOS, are acceptable where non-automobile travel modes are prioritized, such as along Premium Transit and Main Street Corridors. The acceptable LOS also varies as roadways pass through designated Centers where there are high levels of pedestrian activity. [TABLE 7.2.28](#) contains automobile LOS by Center and Corridor type or functional classification.

TABLE 7.2.28 Automobile LOS by Corridor and Location*

Functional Classification & Roadway Type	Transit Station Area	Downtown	Urban Center	Activity Center (Mixed-use)	Village Center	Employment Center	Outside Activity Center
Premium Transit	E-F	E-F	E-F	E-F	E-F	E-F	E-F
Major Transit	E	E-F	E	E	D-E	D-E	D-E
Maint Street	E	E	E	E	D-E	D-E	D-E
Commuter	E	E	D-E	D-E	D-E	D-E	D
Other Arterial	E	E	E	D-E	D-E	D-E	D
Minor Arterial	E	E	D-E	D-E	D-E	D	D
Collector	E	D-E	D	D	C-D	C-D	C-D
Main Street	E	E	E	E	E	E	E

* Table based on [ABC Comp Plan](#).

7-2(C)(5)(iii)(b) Multi-modal LOS

Multi-modal LOS analysis is encouraged as part of the roadway redesign process to identify locations where pedestrian and bicycle infrastructure could be improved. The DPM does not require that a certain multi-modal LOS be obtained or that a particular multi-modal LOS tool be used; however, design principles that support higher multi-modal LOS are integrated throughout the DPM and the [City Standard Specifications](#).

7-2(C)(5)(iii)(c) NMDOT Facilities

NMDOT-owned facilities are not governed by the standards or guidelines contained in the DPM. Coordination with NMDOT is required and standards

from the [NMDOT Design Manual](#) shall be used where a City-led project is undertaken on an NMDOT-owned facility.

Part 7-2(D) Street Elements

Modest differences in design ensure that roadways support the surrounding land use context. Therefore, the design of streets in the City of Albuquerque varies depending on the Corridor type and location. This section defines major street elements and provides general guidance on the principles that govern the design and redesign of roadways.

NOTE: *Right-of-way set-aside is also based on functional class. The right-of-way set-aside does not dictate that the road be designed to meet the dedicated width; the footprint of a roadway may be as narrow as appropriate to meet travel needs.*

The street is divided into 2 areas, and the street elements are associated with one or the other:

1. **Pedestrian Realm:** includes the landscaping area and pedestrian access route (i.e. sidewalk).
2. **Travel Way:** includes the curb-to-curb area used for vehicle and bicycle travel.

Section 7-2(D)(1) Pedestrian Realm

The pedestrian realm is the generally elevated area above the travel way between the curb and the right-of-way line or the property line of the adjacent parcel. The pedestrian realm elements include the frontage zone, sidewalk, and the landscape/buffer zone.

The scale and design of Pedestrian Realm elements vary depending on the Corridor type and location. In general, wider buffers and sidewalks are desired in areas with high levels of pedestrian activity, including designated Centers and along certain designated Corridors. Detailed guidance can be found in [Part 7-4\(E\) Pedestrian Facilities](#), including the application of the standards listed in [TABLE 7.2.27](#) during reconstruction projects.

7-2(D)(1)(i) Frontage Zone

The frontage zone constitutes the segment between the sidewalk and the property line, which may be located within the City right-of-way. The presence of frontage zones reduces the likelihood of encroachments, conflicts between vehicular and pedestrian traffic, and of walls or other vertical structures being erected in the clear sight triangle. Frontage zones are most appropriate on roadways classified as collectors or above, and on non-residential local streets. The frontage zone is typically between 1'-2.5' on all roadways classified as collectors and above. See the Local Streets section for additional guidance.

7-2(D)(1)(ii) Sidewalks

A hard-surfaced walk or raised path and any curb ramps or blended transitions along and generally paralleling the side of the streets for pedestrians. Sidewalks do not include the curb and gutter. For ADA/PROWAG purposes, the sidewalk area is also referred to as the "pedestrian access route," and must be free of obstacles, protruding objects, and vertical obstructions.

7-2(D)(1)(iii) Landscape/Buffer Zone

The landscape/buffer zone, also referred to as the furnishing zone, constitutes the area between the curb and the sidewalk and provides space for signage, utilities, storm water catchment, landscaping, street furnishings, and driveway aprons. The landscape/buffer zone separates the sidewalk from automobile traffic, and allows for the necessary space at crossings to install ADA/PROWAG accessible ramps at intersections. The top of the curb is included in the landscape/buffer zone, but is not considered part of the sidewalk.

Section 7-2(D)(2) Travel Way

The travel way may include curb and gutter, shoulders, bicycle facilities, transit amenities, on-street parking, travel lanes, medians, and turn lanes. Design guidance within the travel way generally depends on the Corridor designation, and whether a roadway segment is located inside or outside of a Center. If roadways have no Corridor designation, guidance is provided by functional classification.

7-2(D)(2)(i) Curb and Gutter

Curb and gutter constitute the area along the edge of a street that separates the elements in the pedestrian realm from the travel way and serves an important role in stormwater management. See [Part 7-4\(D\) Curb and Gutter](#) for general requirements and dimensions. See [Chapter 6 Drainage, Flood Control, and Erosion Control](#) for additional considerations, including low-impact development.

The gutter pan is considered as part of the overall roadway width; it may be counted as part of the width of the curbside travel lane or on-street parking space. The gutter pan is not included as part of the width of a bicycle lane.

7-2(D)(2)(ii) Shoulders

Shoulders are the space between the outside of the driving lane and the curb or roadway edge, and generally serve as a buffer, to provide space for disabled vehicles on high-speed roadways, and to provide space for maintenance and emergency vehicles.

Bicycle lanes may take the place of a shoulder, although buffers between the bicycle lane and the curb may also serve as shoulder space. In rural areas without curb and gutter, the shoulder may be unpaved. The width of the shoulder depends on the location and the available right-of-way.

7-2(D)(2)(iii) Bicycle Facilities

Bicycle facilities include on-street bicycle lanes, separated multi-use paths, and buffers that provide additional comfort and safety for cyclists. See [Part 7-4\(F\) Bikeways and Trails](#) for standards related to bicycle facilities, as well as guidance on the appropriate locations for bicycle facilities.

7-2(D)(2)(iv) Transit Amenities

Dedicated or transit-specific infrastructure may be used within the Travel Way depending on the context, and are more appropriate for some corridor types

than others. Transit stop amenities are generally located in the Pedestrian Realm. See [Part 7-4\(G\) Public Transit](#) for further guidance.

7-2(D)(2)(v) On-street Parking

On-street parking constitutes dedicated areas generally on the edge of the Travel Way and adjacent to the curb for vehicles to park. On-street parking may be parallel or angled, depending on the available right-of-way and the location. See [Part 7-4\(H\) On-street Parking](#) for guidance on appropriate locations and dimensions.

7-2(D)(2)(vi) Travel Lanes

Travel lanes are dedicated areas for vehicle traffic. The design of general purpose travel lanes should be consistent with the intended role of the facility, including the types of vehicle and the needs of all potential users, as well as the surrounding land use context. Bicycle lanes are considered to be travel lanes.

The widths provided in [TABLE 7.2.29](#) are consistent with national standards. Narrow lanes (i.e. the low end of the ranges in [TABLE 7.2.29](#)) can result in lower speeds and reduced crossing distances and are encouraged in locations where a balance of modes is desired, high-speed vehicle travel is less critical, and in areas with high levels of pedestrian activity. Travel lanes narrower than those indicated in [TABLE 7.2.29](#) may be considered under highly constrained conditions and require the approval of the City Engineer.

See [Article 7-4 Design Standards](#) for additional guidance on roadway network design principles. See [Part 7-4\(G\) Public Transit](#) for guidance related to dedicated transit infrastructure and travel lanes where transit operates in mixed flow traffic.

The width of the travel lane is measured from the center of lane striping and the curb face. The gutter pan may be included as part of the width of curbside travel lanes.

7-2(D)(2)(vii) Medians

Medians are the center portion of the roadway that separates general purpose travel lanes moving in opposite directions. Medians frequently incorporate features to provide safety benefits and improve operations by providing space for turning vehicles. Some form of raised or striped median is desirable on principal and minor arterials, with wider medians required along segments with turn lanes or turn bays.

Center turn lanes may be incorporated as part of a median and interspersed with landscaped median islands. Medians may also serve as pedestrian or bicycle refuges, whether as raised features or through pylons, pavement markings, and signage that distinguish the pedestrian safe zone. See [Section 7-4\(I\)\(7\) Median and Turn Lane Design](#) for additional guidance.

7-2(D)(2)(viii) Turn Lanes

Turn lanes provide dedicated space for vehicles to complete a turning movement without blocking the flow of traffic. They may be continuous in the center of a roadway, combined with medians, or located at intersections. Intersection turn

lanes may be on the inside or outside of the road, depending on the turning movement direction. Turn lane width varies depending on the Corridor type, the type of turn lane, and the design speed. See [Section 7-4\(I\)\(7\) Median and Turn Lane Design](#) for more information on various design options.

Section 7-2(D)(3) Design Speed

The design speed by Corridor type and location, as identified in the [ABC Comp Plan](#), is provided in [TABLE 7.2.29](#). The design speed is a function of roadway geometry and reflects the actual speed motorists are intended to travel under free-flow traffic conditions. Standards for the various geometric elements that affect design speed are located throughout the transportation chapter.

The design speeds provided in [TABLE 7.2.29](#) reflect a general approach that slower speeds are more appropriate in locations with high levels of bicycle and pedestrian travel, such as Centers and Corridors, as well as collectors and local streets. Higher design speeds are appropriate outside of Centers and along roadways where vehicle throughput is most critical. Posted speeds are established only after appropriate examination of the completed street by the Traffic Engineer.

Section 7-2(D)(4) Street Element Table

[TABLE 7.2.29](#) summarizes design standards for various street elements by location. The table does not indicate whether the street elements are required for a particular roadway and should be used in combination with the [ABC Comp Plan Table 7-5: Priority Street Element Matrix](#), which provides guidance on roadway elements that should be included on Corridors. For example, sidewalks are required on all roadways in the City of Albuquerque, while the presence of bicycle infrastructure depends on the location and available right-of-way. [TABLE 7.2.29](#) indicates the standard widths when street elements are included.

Achieving standards widths for desired elements may be particularly challenging for roadway reconstruction projects, thus requiring some level of prioritization on individual roadways and consideration of the roles that a series of roads play across the network. For reconstruction projects, the landscape/buffer zone should be provided as space allows.

FIGURE 7.2.41 Street Element Dimensions Along Major Roads

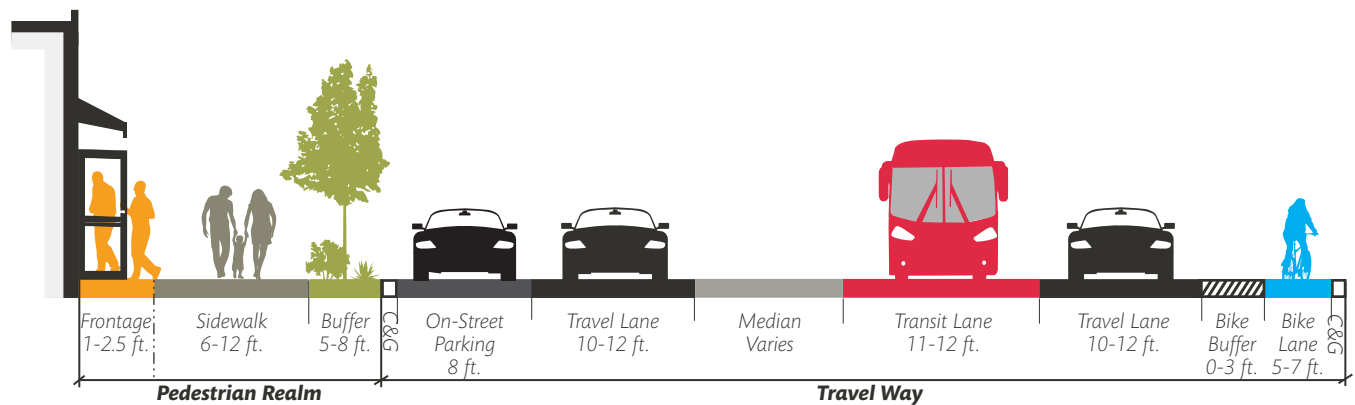

Corridor Type / Classification	Location	Design Speed (MPH)	Pedestrian Realm			Travel Way		
			Frontage Zone (ft.)	Sidewalk Width (ft.)	Landscape / Buffer Zone (ft.)	Bike Lane Width (ft.)*	Bike Buffer (ft.)	Travel Lane Width (ft.)***
Premium Transit	Inside Center	30-35	1-2.5	10-12	6-8	6-6.5	0-3	10-12
	Outside Center	35-40	1-2.5	8-10	6-8	6-7	1.5-3	10-12
Major Transit	Inside Center	30-35	1-2.5	10-12	6-8	5-6.5	0-3	10-12
	Outside Center	35-40	N/A	6-10	6-8	6-7	1.5-3	10-12
Multi-modal	Inside Center	30-35	1-2.5	10-12	6-8	5-6.5	0-3	10-11
	Outside Center	35-40	N/A	6-10	6-8	6-7	1.5-3	10-11
Commuter	Inside Center	30-35	1-2.5	10	6-8	5-6.5	1.5-3	10-12
	Outside Center	40-50	N/A	6	6-8	6-7	3-5	10-12
Main Street	Main Street	25-30	1-2.5	10-12	6-8	5-6.5	0-3	10-11
Other Arterial	Inside Center	30-35	1-2.5	10	6-8	5-6.5	0-3	10-11
	Outside Center	35-40	N/A	6	5-6	6-7	1.5-3	10-11
Minor Arterial	Inside Center	30-35	1-2.5	10	6-8	5-6.5	0-3	10-11
	Outside Center	35-40	N/A	6	5-6	6-6.5	1.5-3	10-11
Major Collector	Inside Center	25-30	1-2.5	10	5-6	5	0-3	10-11
	Outside Center	30-35	N/A	6	5-6	5-6	0-3	10-11
Minor Collector	Inside Center	25-30	1-2.5	10	5-6	5	0-3	10-11
	Outside Center	30-35	N/A	6	5-6	5-6	0-3	10-11
Major Local	Inside / Outside Center	18-30	1-2.5 / N/A	5	5-6	Shared Lane**		See Part 7-4(J) Local Streets
Other Locals	Inside / Outside Center	15-25	1-2.5 / N/A	5	4-6	N/A	N/A	

* Not including the gutter pan.

** Dedicated bicycle infrastructure may be appropriate along some major local roads. In these circumstances, use the design characteristics of a minor collector (inside Center). See [Part 7-4\(J\) Local Streets](#) for more information.

*** See [Part 7-4\(G\) Public Transit](#) for additional guidance on travel lane widths for roads with transit service.

ARTICLE 7-3 ROADWAY DESIGN CONTEXT

Planning efforts in the Albuquerque area emphasize the connection between land use and transportation and creating streets that are appropriate for the surrounding context. To support a range of policy and planning objectives, the design standards and guidance contained in the transportation chapter of the DPM are linked to the location of the roadway and the surrounding land use context.

This section clarifies the relationship among

- Long-range regional planning efforts
- City of Albuquerque policies
- Detailed design standards contained in the transportation chapter of the DPM

Designers are encouraged to refer to this section to understand the sources of DPM design standards and the rationale behind design priorities.

Part 7-3(A) Transportation Planning and Policy

The DPM represents the most specific planning and design document for the City of Albuquerque and connects the general policies and recommendations of planning documents related to land use and transportation to the actual design and function of City infrastructure. In practice, this document translates the policies and vision to location-specific design standards. The Roadway Design Context section describes these key planning documents and how each planning effort builds upon the layer that preceded it (see [FIGURE 7.3.42](#) and [TABLE 7.3.30](#)).

FIGURE 7.3.42 Transportation and Land Use Planning

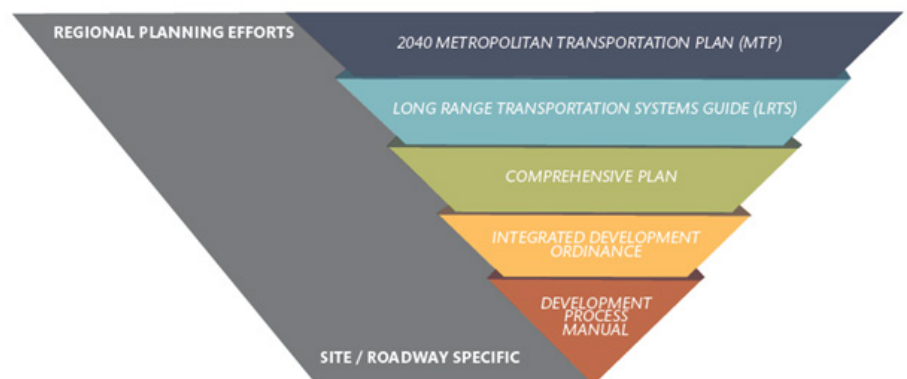

The highest level regional planning takes place through the [MTP](#) and is performed by the MRMPO with the participation of member agencies, including the City of Albuquerque and Bernalillo County. The [MTP](#) examines where growth will take place, identifies strategies for meeting future

transportation needs, and provides a list of all anticipated transportation projects in the 20-plus year timeframe of the plan. The scope of the [MTP](#) has broadened over time as MRMPO began undertaking scenario planning efforts to understand different ways the region could grow and the resulting impacts on the transportation system. Although the [MTP](#) is a regionally-approved document, it relies on local jurisdictions for policy implementation and project development. The most recent [MTP](#) includes the [LRTS Guide](#), which provides right-of-way ranges and general design guidance based on the roadway type and the surrounding land use context.

The [ABC Comp Plan](#) provides a vision for how growth should occur specifically in the City of Albuquerque and in unincorporated portions of Bernalillo County. The plan emphasizes additional development in designated Centers and Corridors and describes the desired characteristics of these locations. The [ABC Comp Plan](#) provides greater detail on Corridor types than the [LRTS Guide](#) or [MTP](#), including policy guidance on the form and function of different facilities.

The [IDO](#) regulates land use, development standards, and some infrastructure for new subdivisions. The [IDO](#) is the primary implementation tool of the [ABC Comp Plan](#); however, for the policies of the [ABC Comp Plan](#) and the regulations of the [IDO](#) to be effective in creating places that support multi-modal transportation, they must be complemented by street design standards, such as those contained in the DPM.

TABLE 7.3.30 Planning Document and Relevance for DPM		
Planning Effort	Level	Scope / Relevance
Metropolitan Transportation Plan	Regional	Policy document and long-term project list
Long Range Transportation Systems Guide	Regional	Regional role of corridors; right-of-way ranges
ABC Comp Plan	City / County	Policy document
Integrated Development Ordinance	City	Zoning code and subdivision ordinance
Development Process Manual	Site / Roadway	Street design and site development guidance

Part 7-3(B) Regional Transportation Planning

Section 7-3(B)(1) Metropolitan Transportation Plan (MTP)

7-3(B)(1)(i) General Purpose

The [MTP](#), updated every 5 years, examines the transportation challenges facing the Albuquerque Metropolitan Planning Area (AMPA) over the next 20-25 years. The reference document at the time of the 2017 Update of the [ABC Comp Plan](#) and the 2018 update to the DPM is the 2015 [Futures 2040 MTP](#).

The [MTP](#) is a product of MRMPPO, a regional government planning agency responsible for long-range transportation planning and for the programming of near-term federal transportation dollars in the AMPA. MRMPPO is housed within MRCOG and works closely with member agencies, such as the City of Albuquerque, Bernalillo County, and other transportation partners and stakeholders to develop the [MTP](#). The [MTP](#) sets priorities for how federal transportation dollars available to the region through the Transportation Improvement Program (TIP) will be allocated. The plan is also the source of the region's household and employment projections and forecasts how population and employment growth is distributed within the metropolitan area.

The role of MRMPPO and the [MTP](#) is to identify long-term regional transportation needs and strategies to address those needs, and to incentivize agencies to pursue programs and projects that have the greatest regional benefits. MRMPPO is overseen and the [MTP](#) must be adopted by the MTB, comprised of elected officials and other representatives from agencies and jurisdictions across the region, including the City of Albuquerque.

7-3(B)(1)(ii) Scenario Planning

In addition to a trend scenario, the regionally-adopted socioeconomic forecast that projects future development patterns based on existing plans and policies, the 2040 [MTP](#) contains a preferred scenario, developed collaboratively with agencies from across the AMPA, which demonstrates that encouraging growth in activity centers and along transit corridors has a range of benefits. These include reduced total driving or vehicle miles traveled (VMT), lower levels of congestion due to more efficient use of the transportation network, improved access to services and employment sites, lower transportation-related CO emissions, and a smaller development footprint that reduces the amount of new housing and employment sites at risk due to the impacts of climate change.

7-3(B)(1)(iii) Relationship between the MTP and City of Albuquerque Planning Documents

The [MTP](#) establishes the general connection between transportation infrastructure and surrounding land use and provides the regional framework under which more specific planning and roadway design efforts take place. The [MTP](#) and the Preferred Scenario are reflected in goals of the [ABC Comp Plan](#) that support increased transportation options and higher density and a mix of land uses in targeted locations. The [MTP](#) and the [ABC Comp Plan](#) share an emphasis on additional development within activity centers and corridors, and designations from the [MTP](#) Priority Transit Network are included in the [ABC Comp Plan](#) as Premium Transit or Major Transit Corridors. See [Section 7-3\(C\)\(2\)](#) for additional discussion on [ABC Comp Plan](#) Center and Corridor designations.

The [MTP](#) and the [ABC Comp Plan](#) also share policies and strategies for reducing VMT and managing congestion, including travel demand management strategies that increase transportation choice by supporting investments in alternative modes of transportation and reduce the number of peak-period single-occupancy vehicle trips. Implementing [MTP](#) goals, particularly those related to alternative modes, requires streetscapes that

support travel options for all users. The DPM specifically supports City and regional planning objectives through roadway design standards.

Section 7-3(B)(2) Long Range Transportation Systems Guide (LRTS Guide)

7-3(B)(2)(i) General Purpose

The [LRTS Guide](#) was developed as part of the 2015 update to the [Futures 2040 MTP](#) and translates Plan recommendations and Complete Streets principles into general street design guidelines. Objectives of the [LRTS Guide](#) include supporting regional travel requirements, balancing the needs of all modes, and ensuring street designs are compatible with the built environment. The [LRTS Guide](#) replaces the Future Albuquerque Area Bikeways and Streets (FAABS) document, which guided new roadway construction for decades.

7-3(B)(2)(ii) Applications of the LRTS Guide in the DPM

Though the design guidance in the [LRTS Guide](#) is largely superseded for the City of Albuquerque by the standards contained in the DPM, there are several components of the [LRTS Guide](#) that apply to roadway design within the City of Albuquerque. (See [TABLE 7.2.27](#).) Critical components of the [LRTS Guide](#) include:

- *Long-range system maps*
- *Right-of-way requirements for new arterials and collectors*
- *Guidance related to overall network design and connectivity*

TABLE 7.3.31 Applications of the LRTS Guide in the DPM		
LRTS Guide Component	DPM Integration / Implications	Action Required by Designer
1. Long Range System Maps	The system maps identify future roadways and bicycle facilities that must be incorporated into subdivision layout and roadway design.	Refer to LRRS and LRBS maps for location of current and future facilities.
2. Right-of-way Guidance	The LRTS Guide is the source for right-of-way requirements for all roads classified as collectors or above. Right-of-way requirements for principal arterials vary depending on whether the corridor is designated as a regional or a community principal arterial.	Refer to table TABLE 7.2.29 on right-of-way ranges.
3. Network Connectivity Standards	The DPM provides standards related to block length, traffic signal space, and pedestrian crossing frequency, among other considerations.	Consult Article 7-4 Design Standards for standards related to block length and the spacing of major roads. Additional guidance related to intersection density and network design for large subdivisions can be found in Part 7-4(A) Network Connectivity and the LRTS Guide .

7-3(B)(2)(iii) Long Range System Maps

The LRRS is the regional network consisting of all existing and proposed arterial and collector roadways. Facilities may be included in the LRRS regardless of whether funding is currently identified. (Only roads with identified funding are included in the [MTP](#).)

The LRBS contains all existing and proposed bikeway and trail facilities. The LRBS consolidates local bicycle planning efforts completed by jurisdictions across the region.

7-3(B)(2)(iv) LRTS Guide and LRRS Roadway Types

The [LRTS Guide](#) provides right-of-way ranges for new roadways by functional classification. (See [Section 7-3\(B\)\(3\)](#) for discussion of functional classification and [Section 7-3\(B\)\(4\)](#) for additional information on right-of-way ranges.) To ensure that the right-of-way required for new principal arterials supports the surrounding context, the LRRS designates regional and community principal arterials, reflecting the fact that roadways with the same functional classification may serve different purposes. Per the [LRTS Guide](#), different levels of right-of-way should be set-aside depending on the designation as a regional or a community principal arterial. These designations also inform the role and function of the roadway, including whether vehicle throughput is prioritized to improve regional mobility, or whether the infrastructure should support a range

of modes and access to local land uses. (See [TABLE 7.3.32](#).)

TABLE 7.3.32 LRRS Roadway Types		
LRRS Roadway Type	Purpose of Designation	Examples
Regional Principal Arterial	Identify facilities where higher speed vehicle travel should be preserved and where access management strategies could be pursued.	Paseo del Norte, Tramway Blvd, Rio Bravo Blvd
Community Principal Arterial	Ensure that a particular mode is not to be prioritized at the expense of others, and that the corridor is meant to bring people to an area as opposed to through the area (as is the case with regional principal arterials).	Central Ave, Irving Blvd, San Mateo Blvd

Section 7-3(B)(3) Functional Classification

7-3(B)(3)(i) General Purpose and Background

Functional classification is used to identify the role of a roadway in moving people and goods, determine eligibility to receive federal funding, and for system monitoring and prioritizing resource allocation. Many jurisdictions also use functional classification in determining maintenance schedules and operational improvements, such as investments in Intelligent Transportation Systems.

FIGURE 7.3.43 Access and Functional Class

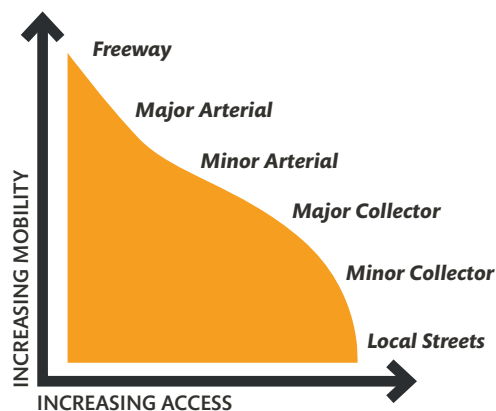

The following factors determine the functional classification of a roadway, including:

- *Mileage (the uninterrupted length of the road).*
- *Traffic volume, including the volume of a facility relative to other routes.*
- *Posted speed and/or observed travel speeds.*
- *Travel lanes and roadway capacity.*
- *Existing land use and future development.*
- *Spacing between routes.*

The purposes of a roadway are particularly important in determining functional classification, including whether a facility is meant to serve longer-distance travel needs (i.e. mobility) or provide access to local land uses. Roads that provide more entrance and exit points and serve shorter distance trips are generally classified as local roads or as collectors, while roads that serve longer-distance trips and connect larger destinations are generally arterial roads. [TABLE 7.3.33](#) defines the typical roadway features by functional classification.

Functional classification within the City of Albuquerque and Bernalillo County were updated in 2015 and are maintained by the NMDOT. All proposed changes to functional classifications must be proposed and approved through MRMPO before final approval by the NMDOT.

7-3(B)(3)(ii) Functional Classification and the DPM

While national design manuals are generally organized around functional classification, the DPM provides detailed roadway design guidance for arterial roadways based on Corridor designations, where applicable. For collectors and arterials where no Corridor designation is applied, guidance and standards are applied by functional classification or design speed. The DPM also provides standards for local streets that provide direct land access and connections to higher order streets. Additional guidance is provided where roadways pass through Centers. Within a major subdivision, City staff may assign a functional classification for new roadways during the review process.

TABLE 7.3.33 Roadway Functional Classification Descriptions

	Description	Design Considerations	Bicycle Infrastructure Options
Functional Classification: Principal Arterial	<ul style="list-style-type: none"> – Generally high traffic-volume corridors serving long-distance trips. – Serve major destinations and centers and provide critical connections across and within a region. – Provide a high degree of mobility for motorists but low levels of land access. 	<ul style="list-style-type: none"> – Generally 2 or 3 through lanes per direction with a central left turn lane. – Regular transit service is common and premium transit with dedicated lanes may be appropriate. – On-street parking may be considered only in activity centers or urban areas with commercial activity. – Due to high speeds and traffic volumes, bikeways should not be included on these roadways if there are existing parallel routes within 1,000 ft. – Narrower lanes can be considered in activity centers and locations with high levels of pedestrian activity. 	<ul style="list-style-type: none"> – Barrier protected bicycle lane/cycle track within activity centers. – Bicycle lane with striped buffer. – Parallel roadways within 1,000 ft. in areas with a grid network. – Adjacent multi-use paths.
Functional Classification: Minor Arterial	<ul style="list-style-type: none"> – Serve trips of moderate length. – Connect to and complement principal arterials, provide intra-community connectivity. – May carry local bus routes. – Provide more land access than principal arterials without penetrating individual neighborhoods. – Generally have fewer lanes, lower speed limits, and lower traffic volumes (6,000-20,000 ADT) than principal arterials 	<ul style="list-style-type: none"> – Generally, 2 through lanes per direction with a central left turn lane. Transit service is common in mixed-flow on general purpose lanes. – On-street parking may be considered in activity centers or urban areas with commercial activity. – Number of lanes should support current or near-term term project traffic volume; excessive capacity should be avoided. – Narrower lanes may be considered in activity centers with high pedestrian volumes. 	<ul style="list-style-type: none"> – Bicycle lane. – Barrier protected bicycle lane/cycle track in activity centers and/or high traffic areas.
Functional Classification: Major Collector	<ul style="list-style-type: none"> – Gather traffic from local roads and channel then onto the arterial network. – Generally serve intra-community travel and provide less mobility and greater land access than arterials. – Feature moderate speed limits and traffic volumes (3,000-12,000 ADT). 	<ul style="list-style-type: none"> – Generally, 1 or 2 through lanes per direction with a central left turn lane. – On-street parking may be considered in activity centers or urban areas with commercial activity. – Number of lanes should support current or near-term term project traffic volume; excessive capacity should be avoided. – Narrower lanes may be considered in activity centers or locations with high pedestrian volumes. 	<ul style="list-style-type: none"> – Bicycle lane. – Sharrows/shared lane where volumes and speeds are low.

(source: FHWA and LRTS Guide)

TABLE 7.3.33 Roadway Functional Classification Descriptions			
	Description	Design Considerations	Bicycle Infrastructure Options
Functional Classification: Minor Collector	<ul style="list-style-type: none"> – Offer a high degree of land access and some degree of mobility for motorists. – Penetrate residential neighborhoods and distribute trips from local roads to the arterial network. – Used for short distances and feature lower speeds and traffic volumes (under 6,000 ADT) than major collectors. 	<ul style="list-style-type: none"> – Generally 1 through lane in each direction; may feature center turn lane. – On-street parking may be considered in activity centers or urban areas with commercial activity. 	<ul style="list-style-type: none"> – Bicycle lane. – Sharrows/shared lane where volumes and speeds are low.
Functional Classification: Local Roads	<ul style="list-style-type: none"> – Provide a high degree of land access, including most roads within residential areas. – Support short trips at low speeds. – Bus routes generally do not run on local roads. – The DPM identifies 3 types of local roads – major, normal, and access – with modest design differences. 	<ul style="list-style-type: none"> – Narrow roadways, though there should be sufficient width to support emergency vehicle access. – On-street parking is generally provided. – Major local roads may function in a similar manner to minor collectors and may contain similar design features. 	<ul style="list-style-type: none"> – Bicycles generally travel with the flow of traffic.

Section 7-3(B)(4) Right-of-way Width

7-3(B)(4)(i) General Considerations

The required right-of-way is a starting point for determining the roadway features that can be accommodated and how to balance modes and desired street elements. Right-of-way ranges should not be understood as encouraging the maximum roadway footprint or the inclusion of all possible roadway features. Roads that are especially wide can accommodate many types of roadway needs and uses, but may make conditions uncomfortable for cyclists, pedestrians, and transit users due to the nearby traffic volume or vehicle speeds, and may require pedestrians to cross long distances.

Per the [LRTS Guide](#), the minimum right-of-way should be set aside to meet the expected needs of the roadway. Right-of-way can be minimized if desired roadway elements, such as bicycle facilities, are incorporated on nearby facilities, or if there is sufficient roadway network density that vehicle travel can be dispersed across many roads and the width of an individual roadway can be limited without compromising auto mobility needs.

7-3(B)(4)(ii) Major Roads

Right-of-way width requirements for all arterials or collectors are determined by the [LRTS Guide](#) and are provided in [TABLE 7.3.34](#) below. More right-of-way

is required for roads with higher functional classification; principal arterials should have wider right-of-way than minor arterials, which should be wider than collectors.

TABLE 7.3.34 Right-of-way Width Ranges for Major Roads

Roadway Type	Right-of-way Width
Regional Principal Arterial	106 ft. - 156 ft.
Community Principal Arterial	96 ft. - 130 ft.
Minor Arterial	82 ft. - 124 ft.
Major Collector	62 ft. - 100 ft.
Minor Collector	48 ft. - 84 ft.

7-3(B)(4)(iii) Local Roads

Right-of-way widths for local roads are provided in [TABLE 7.3.35](#). See [Part 7-4\(J\) Local Streets](#) for additional information.

TABLE 7.3.35 Right-of-way Width Ranges for Local Roads

Corridor Type	Location / Subdivision Type	Right-of-way Width
Access Local	Citywide	44 ft. - 46 ft.
Normal Local	Single-family Residential Areas	48 ft. - 52 ft.
	All Other Areas	48 ft. - 61 ft.
Major Local	Single-family Residential Areas	48' ft. - 58 ft.
	All Other Areas	50 ft. - 73 ft.

7-3(B)(4)(iv) Application to Existing Roads

Limited right-of-way on existing facilities may provide constraints on the available options and force designers to make choices and tradeoffs among street elements. Corridor designations are therefore useful in prioritizing how the available right-of-way should be allocated. Additional right-of-way may be considered but is not required for existing roadways if they are below the ranges provided in the DPM.

Part 7-3(C) Albuquerque/Bernalillo County Comprehensive Plan

Section 7-3(C)(1) General Purpose

The [ABC Comp Plan](#) is the policy document jointly adopted by the City of Albuquerque and Bernalillo County that describes the community's vision for the future and identifies desired policy outcomes. In practice, the [ABC Comp Plan](#) guides discretionary decisions about changes to zoning, development proposals, and public investment decisions. The supporting [IDO](#) is a regulatory document that governs more specific land use considerations, including zoning, subdivision regulations, and site development standards.

Although it is primarily a land use document, the [ABC Comp Plan](#) addresses many issues confronting the City of Albuquerque that are inter-related and must be addressed in a coordinated manner. From a transportation perspective, the plan emphasizes increased transportation options, travel demand management strategies to manage congestion, and connectivity for all modes through “networks for vehicles, bicycling, walking, and transit that provide easy and safe access to employment, amenities, and services.” The [ABC Comp Plan](#) emphasizes not only investments in public transit and infrastructure for non-auto modes, but a more comprehensive examination of the streetscape.

Section 7-3(C)(2) Implications for the DPM

The [ABC Comp Plan](#) contains tools and policies to encourage complementary land uses and transportation infrastructure. The link between land use and transportation in the [ABC Comp Plan](#) is built around the Centers and Corridors framework, which is summarized in the [ABC Comp Plan](#) Vision Map. The Centers and Corridors framework “prioritizes infill and growth in more urban areas and discourages growth in more rural and undeveloped areas” and asserts that “creating multi-modal corridors that connect centers within Albuquerque will be an important element of mobility in the future.” For this framework to be successful, Corridors must have the right infrastructure to enable safe travel within Centers, to connect destinations, and support the needs of a range of users. This policy guidance is expanded into design standards throughout this chapter of the DPM.

In addition to design standards by Corridor type, policy matrices provide general guidance on street design elements and indicate transportation priorities by location.

Section 7-3(C)(3) ABC Comp Plan Corridors

While the [LRTS Guide](#) regional role designations and the roadway functional classification determine the amount of right-of-way that is allocated, the [ABC Comp Plan](#) applies Corridor designations that reflect the different functions that roadways may fulfill and the travel modes that should be incorporated into street design.

The [ABC Comp Plan](#) Corridors comprise a network of roadways that collectively meet the travel needs of Albuquerque and Bernalillo County residents. The network approach means that some Corridors prioritize certain modes over others. (See [TABLE 7.3.36](#).) For example, Commuter Corridors are facilities that play a critical role in the mobility of single-occupancy vehicles (Commuter Corridors are generally consistent with the Regional Principal Arterials designations on the LRRS). Premium Transit and Major Transit Corridors are roadways where space may be allocated for dedicated travel lanes, while Main Street and Multi-modal Corridors balance the needs of various users.

Roadways that are not designated in the [ABC Comp Plan](#) are subject to design guidance based on their functional classification.

TABLE 7.3.36 Relationship among Corridor Types

Functional Classification	Long Range Roadway System	ABC Comp Plan Designation
Principal Arterial*	Regional Principal Arterial / Community Principal Arterial	Premium Transit
		Major Transit
		Multi-modal
		Commuter
		Main Street
		Other

** Some minor arterials are designated in the [ABC Comp Plan](#); however, there are no LRRS designations for minor arterials and all minor arterials have the same right-of-way requirements. All principal arterials are identified on the LRRS as either a regional or community principal arterial.*

Land use and development patterns are also intended to vary by Corridor type. For example, land uses along Major Transit and Main Street Corridors and around Premium Transit Station Areas should include a mix of uses and pedestrian-oriented design. Commuter Corridors are intended for long-distance trips across town by automobile, including limited-access streets, and development along Commuter Corridors should be more auto-oriented. Where Corridors pass through designated Centers, development should include also include pedestrian-oriented design. The characteristics of each Comp Plan Corridor are provided in [TABLE 7.3.37](#).

TABLE 7.3.37 ABC Comp Plan Corridor Designations		
Corridor Designation	Description	Examples
Premium Transit*	Premium Transit Corridors are intended to feature high-quality, high-capacity, high-frequency public transit (e.g. bus rapid transit). These corridors are planned for mixed-use and transit-oriented development within walking distance from transit stations at strategic locations along the corridor, with adequate transitions to single-family neighborhoods behind the corridor.	Central Ave, University Blvd
Major Transit	Major Transit Corridors are anticipated to be served by high frequency and local transit (e.g. Rapid Ride, local, and commuter buses). These corridors prioritize transit above other modes to ensure a convenient and efficient transit system. Walkability on these corridors is key to providing a safe and attractive pedestrian environment, as well as good access for pedestrians, cyclists, and transit users to goods and services along these Corridors and the Centers they connect.	San Mateo Blvd, Lomas Blvd, Coors Blvd
Main Street	Main Street Corridors are intended to be lively, highly walkable streets lined with local-serving businesses. Main Street Corridors are active areas with buildings usually placed right up to the sidewalk, with parking available on-street and to the sides or behind buildings. Main Street Corridors should be well-served by transit with pedestrian amenities such as street trees, landscaping, and wide sidewalks.	Central Ave, 4th St (north of Downtown), Bridge Blvd (South Valley)
Multi-modal	Multi-modal corridors are intended to encourage the redevelopment of aging, auto-oriented commercial strip development to a more mixed-use, pedestrian-oriented environment that focuses heavily on providing safe, multi-modal transportation options. The development of these corridors will enhance the environment for pedestrians and transit users, while nearby parallel streets (if available) may serve bicycle travel.	Isleta Blvd, Menaul Blvd, Paradise Blvd
Commuter	Commuter Corridors are higher-speed and higher-traffic volume routes for people traveling across town, usually via limited-access roadways. Access controls on these corridors influence the location and mix of land uses and the design of development. Development sites along Commuter Corridors should be buffered from the roadway. Motor vehicles are prioritized on these corridors, though safe conditions for pedestrians may be supported through landscaping, buffers, and medians.	Unser Blvd, Paseo del Norte, Gibson Blvd, Tramway Blvd
Other	Some roadways, including all collectors and the majority of minor arterials, do not have a Corridor designation. Undesignated corridors do not serve a function that specifically requires any particular mode to be prioritized over others. Per the Complete Streets Ordinance, these corridors require consideration of all users. Design for undesignated corridors should be based on the functional classification.	Juan Tabo Blvd, Academy Blvd

* Premium Transit Corridors function as an overlay on a primary Corridor designation. Design standards in the DPM are generally provided for Premium Transit station areas, defined as the area within a 660 ft. radius around transit stations. Outside of Premium Transit station areas, the underlying Corridor designation informs roadway design and land use considerations; however, Premium Transit Corridors may require dedicated infrastructure and special design considerations along the length of the roadway.

Section 7-3(C)(4) **ABC Comp Plan Centers**

The design standards in this chapter often vary depending on whether the site being developed or the roadway passes through a designated Center. Most Centers are areas of relatively intense development characterized by a variety of uses that allow for many different activities. The [ABC Comp Plan](#) designates 5 types of Centers on a spectrum of development density, intensity of land use and activity, and market area size. See the Vision Map in the [ABC Comp Plan](#) to determine if a project is located in a Center.

TABLE 7.3.38 ABC Comp Plan Center Types and Definitions

Center Type	Description	Examples
Downtown	Albuquerque’s Downtown serves as a regional hub for concentrated job and commercial activity supported by high-density housing and includes a wide variety of land uses. Downtown is intended to have the highest intensity of employment and commercial uses in the region and to offer a high-quality environment for pedestrians. This mixed-use district should include multiple transportation options, street trees, wide sidewalks, and easy-to-use wayfinding signs.	Downtown Albuquerque
Urban Center	Urban Centers are walkable districts that incorporate a mix of employment, service, and residential uses at a density and intensity lower than Downtown but higher than neighborhood-serving Activity Centers. Urban centers are easily accessed by transit and provide opportunities for people to live, work, learn, shop, and play. Urban Centers are intended to become more walkable over time through investments in streetscape amenities, attracting infill development, and locating services closer to nearby residents.	Uptown, Volcano Heights
Activity Center	Activity Centers provide convenient, day-to-day services at a neighborhood scale to serve the surrounding area within a 20-minute walk or a short bicycle ride. These smaller centers should incorporate pedestrian-friendly design and are appropriate for mixed-use and multi-family housing.	UNM, San Mateo Blvd & Montgomery Blvd, Coors Blvd & Montaña Rd
Employment Center	Employment Centers are intended to remain predominately industrial, business, and retail centers. Employment Centers tend to be auto-oriented are generally located at major intersections or along highways or major arterials that provide access for trucks and connections for freight. Street design should emphasize efficient movement of vehicles and pedestrian accommodation within business parks.	Journal Center, Kirtland AFB, Albuquerque Sunport
Village Center	Village Centers are located in unincorporated areas of Bernalillo County and include a variety of retail and commercial services. As of the adoption of the 2017 ABC Comp Plan, there are no Village Centers within the City limits.	N/A

Section 7-3(C)(5) Policy Matrices

Roadways should contain different features depending on the Corridor type, surrounding land use, and whether a roadway design is being developed for inside or outside of a designated Center. The policy matrices contained in the [ABC Comp Plan](#) – described below and summarized in [TABLE 7.3.39](#) – provide guidance on how street design and development form should vary depending on the location and context. These matrices should be referenced during the roadway design process. Various aspects of the matrices have been incorporated into the DPM. For example, the acceptable LOS determined through a traffic impact study varies depending on the location.

The street design policy matrix indicates desired urban form and roadway characteristics by Corridor type and location. Design considerations include: access management, design speed, peak hour LOS, priority travel mode, transit accommodations, signalized intersections, on-street parking, pedestrian facilities and streetscape improvements, sidewalk width, landscaping and buffers, and bicycle facilities. The matrix differentiates between desired roadway form inside and outside of designated Centers or Premium Transit station areas. Many of these characteristics are built into the design standards of the DPM; however, the matrices should be considered for additional guidance on the desired urban form and street design context.

The [ABC Comp Plan](#) Table 7-5: Priority Street Element Matrix takes the street design matrices a step further by providing guidance on which travel modes and street elements to prioritize along designated Corridors. As not all street elements can or should be included along a particular roadway, the matrix provides direction on how to balance and prioritize the available right-of-way with the needs of various users in different locations and contexts.

Two land use development form matrices, one for Centers and one for Corridors, identify the desired land use mix and provide guidance on parking and characteristics of the built environment. An important difference to note in the Location column in [TABLE 7.3.39](#) is the relationship between the buildings and the street, including setbacks and building access.

TABLE 7.3.39 ABC Comp Plan Matrices – Descriptions and Relevance to DPM

Matrix	Location	Description	Relevance to DPM
Street Design Policy Matrices – Corridors	Chapter 6: Transportation – Policies by Corridor type (6.1.4-6.1.9)	General guidance on desired roadway character and the types of roadway elements that would ideally be incorporated along each Corridor type. Identifies desired size and scale of roadway elements and accommodations for alternative modes.	Identifies roadway character through guidance related to Corridor type and land use context. The DPM is the source of design specifications.
Street Elements Matrix	Chapter 7: Urban Design – Policies on Development Form (7.1.3 – Table 7-5)	Identifies which modes and roadway features should be accommodated within the City right-of-way given the surrounding land use context. The extent of available right-of-way may force designers to make tradeoffs and balance between needs.	Informs desired street elements and provides policy guidance for prioritizing elements within limited right-of-way. The street elements priority matrix should be used in combination with the dimensions outlined in the DPM standards.
Development Form Matrix – Centers	Chapter 7: Urban Design – Policies on Development Form (7.1.3 – Table 7-3)	Identifies general land use mix, characteristics of the built environment, and relationship between buildings and the street within designated Centers. Guidance includes setbacks, building access, parking requirements, and parking location.	Contains considerations related to block length, site access, and desired level of network connectivity.
Development Form Matrix – Corridors	Chapter 7: Urban Design – Policies on Development Form (7.1.3 – Table 7-4)	Identifies general land use mix, characteristics of the built environment, and relationship between buildings and the street along linear Corridors. Guidance includes setbacks, building access, parking requirements, and parking location.	Contains considerations related to block length, site access, and desired level of network connectivity.

Section 7-3(C)(6) Other Considerations

7-3(C)(6)(i) Areas of Change and Consistency

Other designations in the [ABC Comp Plan](#) are important to note as they influence the intended form and function of certain areas within the City, but are not generally incorporated into roadway design standards contained in DPM. All Centers and Corridors, with the exception of Commuter Corridors, are considered **Areas of Change**. These locations are intended to be supported by transit service and pedestrian travel opportunities, and contain land use patterns that encourage additional growth, higher levels of density, and more intense levels of development. **Areas of Consistency** are locations where existing land use regulations take precedent and where zoning changes are discouraged. All new development in areas of consistency should be at the scale and intensity of surrounding neighborhoods. Commuter Corridors, which promote auto travel, are areas of consistency.

7-3(C)(6)(ii) Other City Planning Documents

Community stakeholders have provided input about roadway design as part of formal public outreach processes for a number of locations across the City. Cross sections that were developed as part of an approved City planning process or study within the last 10 years should be considered as the basis for roadway design options within that planning or study area. Applicable plans and studies are posted on the [Planning webpage](#).

Part 7-3(D) City of Albuquerque Complete Streets Ordinance

Section 7-3(D)(1) Definition of Complete Streets

[Part 6-5-6 ROA 1994](#), the City's Complete Streets Ordinance, defines Complete Streets as follows: "roadway(s) with cross sections (including City right-of-way and public or private easements abutting a City right-of-way that are designated for a roadway) built at a human scale, designed and operated for equal access by all users, including pedestrians, bicyclists, motorists and transit riders of all ages and abilities, to allow comfortable and convenient street crossings, and pedestrian access to adjacent land uses. Complete Streets components include, but are not limited to, sidewalks, bicycle lanes, dedicated bus lanes, comfortable and accessible public transportation stops, frequent and comfortable pedestrian crossing opportunities, median pedestrian islands, accessible pedestrian signals, curb extensions and pedestrian bulb-outs, reduced travel lane widths determined by the design speed of the roadway, context-appropriate curb return radii, roundabouts, or other features that accommodate efficient multi-modal travel."

Section 7-3(D)(2) Purpose of Ordinance

The Complete Streets Ordinance, adopted in 2015 and updated in 2019, calls for formal consideration of multi-modal roadway elements as part of the street design and re-design process in established areas of the City. The Complete

Streets Ordinance follows a similar resolution passed by the MTB of MRMPO and responds to the fact that “much of Albuquerque’s existing roadway system was built to facilitate access to destinations by personal automobile, resulting in streets that are uninviting and impractical for other users.” In their place, roadways should be designed to be context sensitive and to create multiple transportation options, where practical. To achieve this, roads should balance sufficient vehicle mobility needs with sidewalks, bicycle lanes, transit amenities, traffic calming measures, and convenient pedestrian crossings.

Section 7-3(D)(3) Street Design and Implementation

The Complete Streets Ordinance requires any project that would alter or otherwise affect streets to consider ways to mitigate insufficient multi-modal infrastructure that does not meet design standards. The Complete Streets Ordinance does not apply to basic maintenance projects such as patching, cleaning, or sidewalk repair that do not involve resurfacing, restriping, or reconfiguring the roadway.

Multi-modal infrastructure is to be introduced through traffic calming techniques, including but not limited to narrowing and/or removing general purpose lanes and reallocating space to other users, introducing parallel parking, and by providing buffers between vehicle traffic and pedestrian and bicycle facilities.

Section 7-3(D)(4) Connection Between the Complete Streets Ordinance and the DPM

The DPM incorporates Complete Streets principles and design considerations to ensure that multi-modal transportation infrastructure and context-sensitive design solutions are contained in all roadway redesign and new construction projects. Complete Streets design principles are most heavily emphasized in the design standards for designated Centers and Corridors and through the policy matrices in the [ABC Comp Plan](#).

[DPM Part 7-2\(C\)](#) outlines the steps to be followed by City staff or contractors during roadway redesign or new construction projects. The design review process applies to all roads classified as collector or above and requires designers to examine the existing infrastructure and determine whether or not desired street elements are presently available. [DPM Part 7-2\(C\)](#) also identifies the relevant planning guidance that should be considered for prioritizing roadway elements, including regional transit and bicycle corridor designations, and Tables 7-3, 7-4, and 7-5 (Development Form and Priority Street Element Matrices) in the [ABC Comp Plan](#).

Part 7-3(E) Principles of Network Design and Roadway Connectivity

The [ABC Comp Plan](#) emphasizes that roadway networks be designed in ways that promote transportation options and make destinations as accessible as possible. This section provides additional background on the purpose and intent of network design principles discussed in the [LRTS Guide](#) and the [ABC](#)

[Comp Plan](#) and their implications for roadway design. Specific guidance related to connectivity standards is located in [Article 7-4 Design Standards](#).

Section 7-3(E)(1) Connectivity

Connectivity affects the ability of travelers to efficiently reach their destinations; it is a function of the number of intersections, or intersection density, and the layout of the roadway network. Well-connected networks include numerous intersections, shorter block lengths, and few dead-end roads. Benefits of connectivity include: direct travel routes between destinations, which reduces VMT and improves air quality; dispersing traffic across multiple roadways to reduce congestion, including during traffic incidents; providing better emergency vehicle access; and creating shorter and more direct bicycle and pedestrian routes. Well-connected networks can also help avoid situations where property access falls directly onto arterials.

The [LRTS Guide](#) provides general guidance and strategies for improving connectivity and ensuring that transportation networks work for all users. Connectivity strategies include large-scale measures such as the presence of regional networks by travel mode and establishing standards for intersections per square mile and roadway spacing, as well as smaller-scale strategies such as using access easements and drainage utilities for creating connections and wall breaks or paths for providing access from residential subdivisions to the external transportation network.

FIGURE 7.3.44 Pedestrian Access to Cul-de-sac Example



The [IDO](#) specifies that new subdivisions include neighborhood-level roadway networks that connect to and are integrated with the regional transportation system. In addition to the design of roadways themselves, the best means of ensuring this integration is through standards related to block length and intersection density. Local roads also support the regional network by ensuring adequate access to regional roads, and the layout of local roads is critical to developing highly-connected networks that better support non-motorized travel.

Section 7-3(E)(2) Regional Connectivity and Spacing of Major Roads

The network of arterial and collector roadways provides connections across the City of Albuquerque and the larger region. These major roads should be spaced at regular intervals as the most efficient roadway networks in urban areas provide nearby parallel streets to allow for flexibility and route options. The regional roadway network layout should emphasize redundancy with many route options. Networks that rely on a few large-scale high-capacity roadways should be avoided as they generally become congested, inhibit pedestrian circulation, and compromise safety.

Per ITE access management guidance, the spacing between arterials should be no more than 1 mile apart. The network layout and level of connectivity should support the desired development and land use patterns, and the spacing of arterials and collectors should balance traffic flow demands with needs of non-motorized travel modes. Arterials may be spaced as close as ½ mile apart in areas with high levels of pedestrian activity, such as Downtown or an Urban Center. Arterials and collectors should be spaced more closely together in areas within denser networks and shorter block lengths. Larger spacing is more appropriate in rural and residential areas, but the network in those areas must still provide adequate bicycle and pedestrian connections.

Arterials and collectors should be interspersed to create a system of thoroughfares and parallel facilities that collectively meet the needs of a range of users. Guidance for the spacing of signalized intersections and designated pedestrian crossings are provided in [Part 7-4\(E\) Pedestrian Facilities](#)

Section 7-3(E)(3) Neighborhood Connectivity

The layout and density of local streets within a neighborhood influences internal circulation patterns as well as access to the external roadway network. Local roads should provide short, direct routes that connect residential neighborhoods with commercial areas, schools, other neighborhoods, and arterials where transit service is most likely to be found.

Bicycle and pedestrian access to the external roadway network should be provided at regular intervals (i.e. no more than ¼ mile apart). If street connections are not feasible or not appropriate for the location, access may be provided via wall breaks. Bicycle routes on neighborhood streets that are parallel to arterials also provide a safe and comfortable alternative to cyclists rather than traveling along on-street bicycle lanes on arterials.

Cul-de-sacs and stub streets are generally prohibited as they limit the ability to access the regional roadway network. (See [IDO Subsection 14-16-5-3\(E\)\(1\)\(D\) \(Stubs Streets and Cul-de-sacs\)](#) for exceptions and [Part 7-4\(J\) Local Streets](#) for additional guidance on discontinuous streets.)

Section 7-3(E)(4) Intersection Density

Intersection density refers to the number of intersections in the road network for a particular area. Intersection density is a function of block length, road layout, and parcel size, and should be considered during the planning of medium- and large-scale developments.

Greater intersection density and shorter block lengths are most appropriate in Centers and Premium Transit station areas that promote high levels of pedestrian activity. Intersection density may be lower and block lengths may be longer in residential and industrial areas, or commercial areas and Employment Centers with low levels of pedestrian activity.

Sufficient intersections should be provided within residential neighborhoods to allow for the circulation of pedestrians and cyclists and to allow access to the regional network. [TABLE 7.3.40](#) provides guidance on intersection density, adapted from the [LRTS Guide](#) to City of Albuquerque land use designations.

TABLE 7.3.40 Intersection Density by Location, LRTS Guide	
Location	Intersection Density
Downtown	100 - 200 / sq. mi.
Urban Center	80 - 120 / sq. mi.
Activity Center	60 - 100 / sq. mi.
Employment Center	40 - 100 / sq. mi.
Residential Areas	30 - 50 / sq. mi.
Other Areas	30 - 50 / sq. mi.

Section 7-3(E)(5) Regional Network Considerations

7-3(E)(5)(i) Layered Roadway Networks

FIGURE 7.3.45 Layered Networks

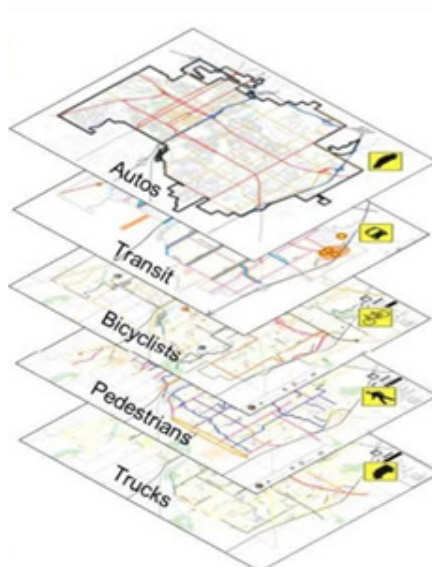

The spacing of arterials and collectors and intersection density standards support layered roadway networks that provide route choice and create opportunities for all modes across the larger system. Each individual roadway does not have to meet the needs of all users if there are accessible facilities on nearby parallel routes. Rather, roadway networks should be created to encourage pedestrian and bicycle travel across the system and to enable freight movement on key corridors. Bicycle facilities may be preferable on nearby parallel roads (either a parallel collector or local road) with lower speeds and traffic volume than principal arterials.

7-3(E)(5)(ii) Limited Access Facilities

MRMPO maintains an inventory of limited access roadways across the AMPA. These roadways are subject to additional guidance with regards to intersection spacing and the intervals between traffic signals. The MRMPO roadway access policies should be consulted for projects located along designated limited access facilities.

ARTICLE 7-4 DESIGN STANDARDS

Part 7-4(A) Network Connectivity

Section 7-4(A)(1) Purpose

This section provides guidance on the spacing and layout of roads, blocks, and pedestrian crossings and recommendations for integrating road design and site development with the regional transportation system, as defined in the LRRS.

Section 7-4(A)(2) Definition of Terms

1. **Regional roadway network:** refers to the system of collector and arterial roadways (also referred to as major roads) that provide mobility and access across the city. See [FIGURE 7.4.46](#).
2. **Neighborhood roadway network:** refers to the local streets, often in a residential area, that are surrounded by the regional roadway network.

FIGURE 7.4.46 Regional and Neighborhood Roadway Networks

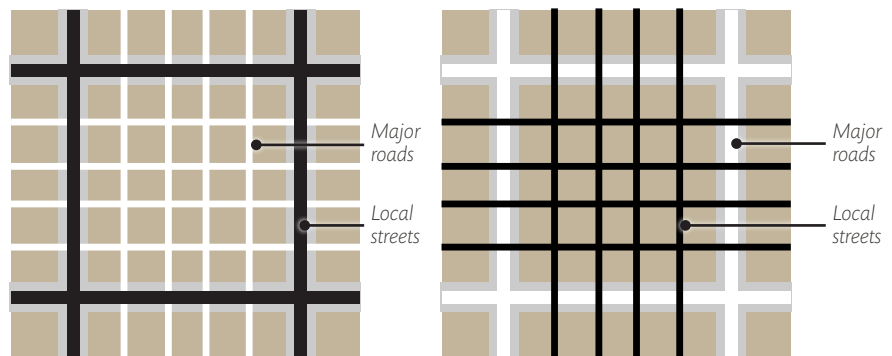

3. **Arterial/collector spacing:** the distance between major roads along a corridor. Unless there is a grade separation, intersections of collectors and arterials are controlled by traffic signals.
4. **Block length:** the length of roadway between 2 intersections. The intersections at the end of blocks maybe signalized or unsignalized depending on the roadway type.
5. **Designated pedestrian crossing:** a location where pedestrians are encouraged to cross a roadway, as indicated by a combination of signal devices, signage, or pavement markings. (See [Section 7-4\(A\)\(7\)](#).)
6. **Signalized pedestrian crossing:** a designated pedestrian crossing where traffic is forced to stop and the pedestrian is protected by a traffic signal or pedestrian-activated signal device.
7. **Signalized intersection:** an intersection where vehicles are managed through a traffic signal. Pedestrian crossings are typically provided at signalized intersections.
8. **Mid-block crossing:** a designated pedestrian crossing not located at an intersection. Mid-block crossings provide direct access to destinations and reduce the distance between intersections with designated crossings.
9. **Controlled Pedestrian Crossing:** a location where vehicles in all directions are managed with traffic control devices that may facilitate pedestrian crossing. See [FIGURE 7.4.47](#).

FIGURE 7.4.47 Controlled Pedestrian Crossing Example

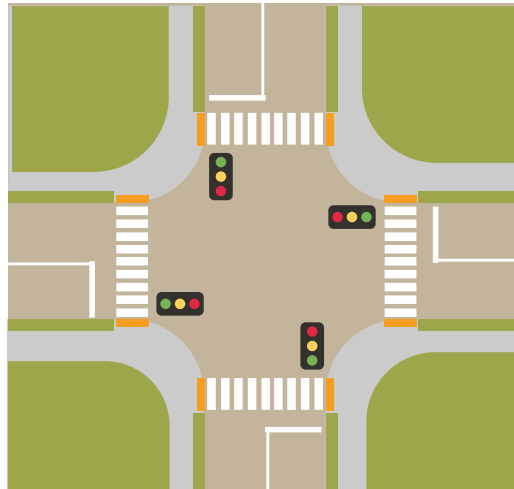

10. **Uncontrolled Pedestrian Crossing:** a location where pedestrians may cross a roadway where vehicles are not controlled. Pedestrian crossings with pavement markings and signage are an example of both uncontrolled and designated pedestrian crossing. See [Section 7-4\(A\)\(7\) Designated Pedestrian Crossings](#) for guidance regarding designated pedestrian crossings and [FIGURE 7.4.48 Uncontrolled Pedestrian Crossing Example](#).

FIGURE 7.4.48 Uncontrolled Pedestrian Crossing Example

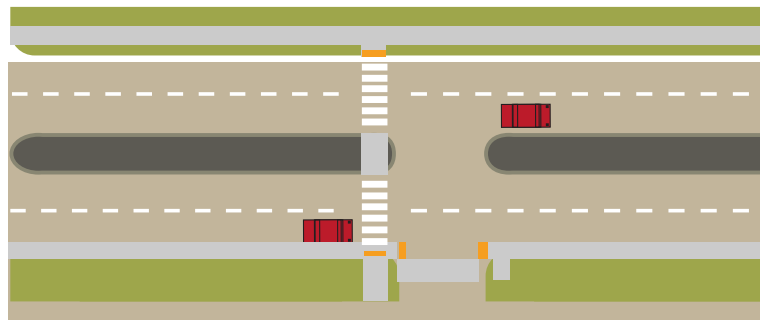

Section 7-4(A)(3) Connectivity

Connectivity affects the ability of travelers to efficiently reach their destinations. The network characteristics standards in [TABLE 7.4.41](#) are intended to promote well-connected networks, including numerous intersections, shorter block lengths, and adequate pedestrian crossings. See [Article 7-3 Roadway Design Context](#) for additional discussion.

TABLE 7.4.41 Characteristics by Location

Location	Major Road Spacing	Block Length	Signalized Pedestrian Crossing	Designated Pedestrian Crossing
Downtown	1,320 ft. - 2,640 ft. (¼ to ½ mile)	200 ft. - 400 ft.	≤660 ft. (⅛ mile)	≤400 ft.
Urban Center	1,320 ft. - 2,640 ft. (¼ to ½ mile)	300 ft. - 400 ft.	≤660 ft. (⅛ mile)	≤400 ft.
Activity Center	1,320 ft. - 2,640 ft. (¼ to ½ mile)	400 ft. - 600 ft.	≤1,320 ft. (¼ mile)	≤600 ft.
Employment Center	≤2,640 ft. (½ mile)	≤800 ft.	≤2,640 ft. (½ mile)	As appropriate*
Village Center	1,320 ft. - 2,640 ft. (¼ to ½ mile)	400 ft. - 600 ft.	≤1,320 (¼ mile)	≤600 ft.
Other Areas / Local Streets	≤2,640 ft. (½ mile)	≤600 ft.	≤2,640ft. (½ mile)	As appropriate*
Main Street Corridor	1,320 ft. - 2,640 ft. (¼ to ½ mile)	300 ft. - 400 ft.	≤660 ft. (⅛ mile)	≤400 ft.

* See [Section 7-4\(A\)\(7\)](#) and [FIGURE 7.4.50](#).

7-4(A)(3)(i) Regional Connectivity and Spacing of Major Roads

1. [TABLE 7.4.41](#) designates the recommended spacing between major roads. This table does not differentiate between principal and minor arterials or major and minor collectors, since the most important consideration from a connectivity perspective is the frequency of major roads.
2. Arterials should be spaced no more than 1 mile apart. Arterials may be spaced as close as ¼ mile apart in areas with high levels of pedestrian activity, such as Downtown or Urban Centers.
3. Arterials and collectors should be interspersed to create a system of thoroughfares and parallel facilities that collectively meet the needs of a range of users.
4. Arterials and collectors should be spaced more closely together in areas within denser networks and shorter block lengths. Larger spacing is more appropriate in rural and residential areas, though the network must provide adequate bicycle and pedestrian connections.

7-4(A)(3)(ii) Neighborhood Connectivity

1. Local streets shall provide short, direct routes that connect residential neighborhoods with commercial areas, schools, other neighborhoods, and arterials where transit service is most likely to be found. (See [FIGURE 7.4.49](#).)
2. Bicycle and pedestrian access points shall be provided to the regional roadway network or existing bicycle facility at least every ¼ mile. If street connections are not feasible or not appropriate for the location, access may be provided via wall breaks. (See [FIGURE 7.4.49](#) and [FIGURE 7.4.50](#).)
3. Cul-de-sacs and stub streets limit the ability to access the regional roadway network. See [IDO Subsection 5-3\(E\)\(1\)\(d\) Stub Streets and Cul-de-sacs](#) and [Section 7-4\(J\)\(3\) Stub, Cul-de-sac, and Loop Street Criteria](#) for appropriate locations and restrictions.
4. See [Part 7-4\(J\) Local Streets](#) for additional guidance on discontinuous streets and residential access via a single driveway.

FIGURE 7.4.49 Neighborhood Connectivity



Section 7-4(A)(4) General Network Considerations

7-4(A)(4)(i) General Block Layout

Blocks shall follow a square or rectilinear grid system, where feasible. Alignments may vary depending on topography, to protect natural features, to respond to site constraints, or to meet the needs of a particular set of land uses.

7-4(A)(4)(ii) Major Roads and ABC Comp Plan Centers

1. Arterials and collectors shall provide direct connections to Centers.
2. Major roads should comprise a network in which a series of parallel facilities collectively meet the needs of all users and provide sufficient capacity within designated Centers. (See [Article 7-3 Roadway Design Context](#) for additional discussion.)
3. Networks should be designed to ensure delivery trucks are accommodated and may reach their destinations. Accommodations for large delivery trucks (i.e. greater than SU-30) are not required on all roads.
4. Commuter Corridors should pass along the edges rather than through a Center. Where Commuter Corridors pass through or bisect Centers, the road design should transition to a typical section that supports the adjacent land use with slower design speeds and improved access to businesses and residential areas.

7-4(A)(4)(iii) Limited Access Facilities

Consult the [MRCOG Roadway Access Policies](#) for designated limited access facilities. These roadways are subject to additional guidance with regards to driveways, intersection spacing and the intervals between traffic signals.

7-4(A)(4)(iv) Right-of-way Allocation

See [Article 7-3 Roadway Design Context](#) for the required right-of-way allocation by functional classification for new roadways. Per the [LRTS Guide](#), right-of-way values at the low end of the range are most appropriate if there is a high density of parallel facilities. Narrower facilities also reduce barriers for pedestrians and cyclists when crossing the street.

Section 7-4(A)(5) Block Lengths

7-4(A)(5)(i) General Provisions

1. Block length refers to the distance along a roadway between intersections. Block lengths vary depending on the roadway type and whether the roadway is located in a Center, with shorter block lengths most appropriate in high pedestrian activity areas.
2. See [TABLE 7.4.41](#) for block lengths by location.
3. The maximum block length for collectors and arterials is 600 feet, except where access limitations are applied.
4. Along limited access facilities, business access or backage roads are strongly encouraged with pedestrian connections to the arterial provided every 600 feet or less.
5. The maximum block length along local streets is 600 feet. (See [IDO Section 14-16-5-4\(E\)\(3\)\(b\)](#) for exceptions). See [Part 7-4\(J\) Local Streets](#) for guidance on cul-de-sacs and stub streets.
6. Mid-block crossings shall be considered and are strongly encouraged for new streets in the following circumstances:
 - a. *Downtown and Urban Centers and along Main Street Corridors where block lengths exceed 400 feet. The mid-block crossing shall be located at the middle of the block to the greatest extent feasible.*
 - b. *Other areas and any new development where block lengths exceed 600 feet. The mid-block crossing shall be located at the middle of the block to the greatest extent feasible.*
7. See [Section 7-4\(A\)\(7\) Designated Pedestrian Crossings](#) for more information on crossings at intersections and mid-block locations.

Section 7-4(A)(6) Traffic Signal Spacing

7-4(A)(6)(i) General Provisions

1. Traffic signals are located at intersections to manage the flow of traffic and allow for safe pedestrian crossing. See [Section 7-4\(I\)\(6\)](#) for additional information on traffic control devices.
2. Standards for intervals between traffic signals can be found in [TABLE 7.4.42](#).
3. Outside of Centers, traffic signal spacing less than ¼ mile is discouraged and requires approval by the City Engineer.
4. Along high auto volume roadways, such as Commuter Corridors, signalized intersections should be evenly spaced and at intervals that ensure efficient flow of vehicles (generally ½ mile).
5. The spacing between signals along Major Transit, Multi-modal, and Main Street Corridors should be at the low end of the range provided in [TABLE 7.4.41](#) where practical, to ensure greater connectivity and opportunities for pedestrian crossings.
6. Within Centers, signalized intersections may be appropriate at intervals below the distance ranges provided in [TABLE 7.4.42](#).
7. Unless the intersection is grade-separated, all intersections between arterial and collectors shall be controlled with signalized pedestrian crossings.
8. Intersections where arterials and collectors intersect with local streets may be unsignalized. See [FIGURE 7.4.50](#) for an example of the spacing of traffic signals and pedestrian crossings.

- Intersections involving 2 local streets are generally served by stop or yield sign controls.

TABLE 7.4.42 Recommended Distance between Signalized Intersections by Corridor Type

Corridor	Distance between Signalized Intersections	Distance between Signalized Pedestrian Crossings
Major Transit	1,320 ft. - 2,640 ft. (¼ - ½ mile)	1,320 ft. (¼ mile)
Multi-modal	1,320 ft. - 2,640 ft. (¼ - ½ mile)	1,320 ft. (¼ mile)
Main Street	1,320 ft. (¼ mile)	660 ft. (⅙ mile)
Commuter	2,640 ft. - 5,280 ft. (½ - 1 mile)	2,640 ft. (½ mile)
Other Arterial	2,640 ft. (½ mile)	2,640 ft. (½ mile)
Minor Arterial	1,320 ft. - 2,640 ft. (¼ - ½ mile)	1,320 ft. (¼ mile)
Collector	1,320 ft. - 2,640 ft. (¼ - ½ mile)	1,320 ft. (¼ mile)

FIGURE 7.4.50 Example Layout: Signalized Intersections & Pedestrian Crossings

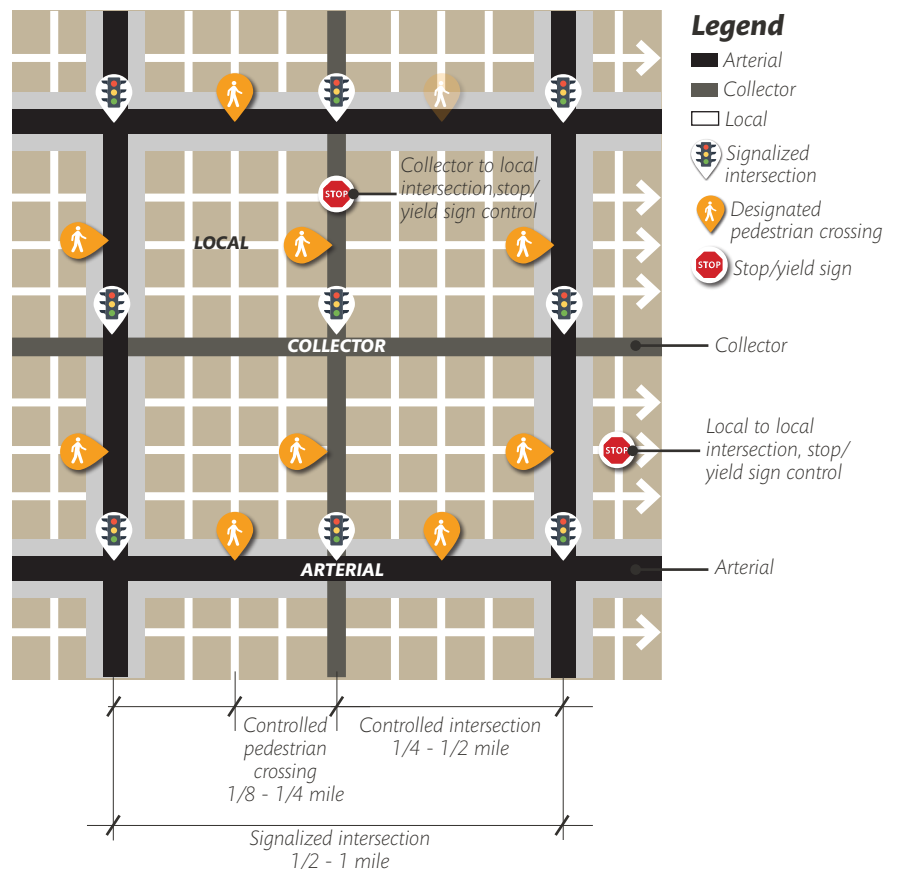

Section 7-4(A)(7) Designated Pedestrian Crossings

7-4(A)(7)(i) Definitions and General Provisions

1. The locations where pedestrians are encouraged to cross a roadway, as indicated by a combination of signal, signage, or pavement markings. While motorists are required by state law to stop for pedestrians crossing a roadway within a crosswalk, some forms of pedestrian crossings provide a higher level of safety and comfort than others. The type of crossing infrastructure depends on the location, traffic volume, and other considerations. (See warranting criteria in [Subsection 7-4\(A\)\(7\)\(iii\)\(a\)](#).)
2. Designated pedestrian crossings may be located at unsignalized or signalized intersections, and may be protected via a traffic signal or pedestrian-activated signal device, or unprotected with elements such as flashing beacons, pavement markings, and signage.

7-4(A)(7)(ii) Types of Designated Crossings

1. A higher level of safety and comfort for pedestrians are provided by traffic control signals, including pedestrian hybrid beacons that completely stop the flow of traffic through a pedestrian-activated sensor.
2. The crossing types listed in [TABLE 7.4.43](#) are ordered from higher to lower form of safety and comfort.
3. Multiple measures should be combined at a crossing, such as a marked crosswalk and a pedestrian refuge island.
4. Traffic volume and the number of lanes of traffic that must be crossed should be considered when determining the most appropriate type of designated pedestrian crossing.
5. Examples of crosswalk design and pedestrian refuge islands are provided in [FIGURE 7.4.52](#).
6. For signage type and placement of hybrid and flashing beacons, see [MUTCD](#) guidance.

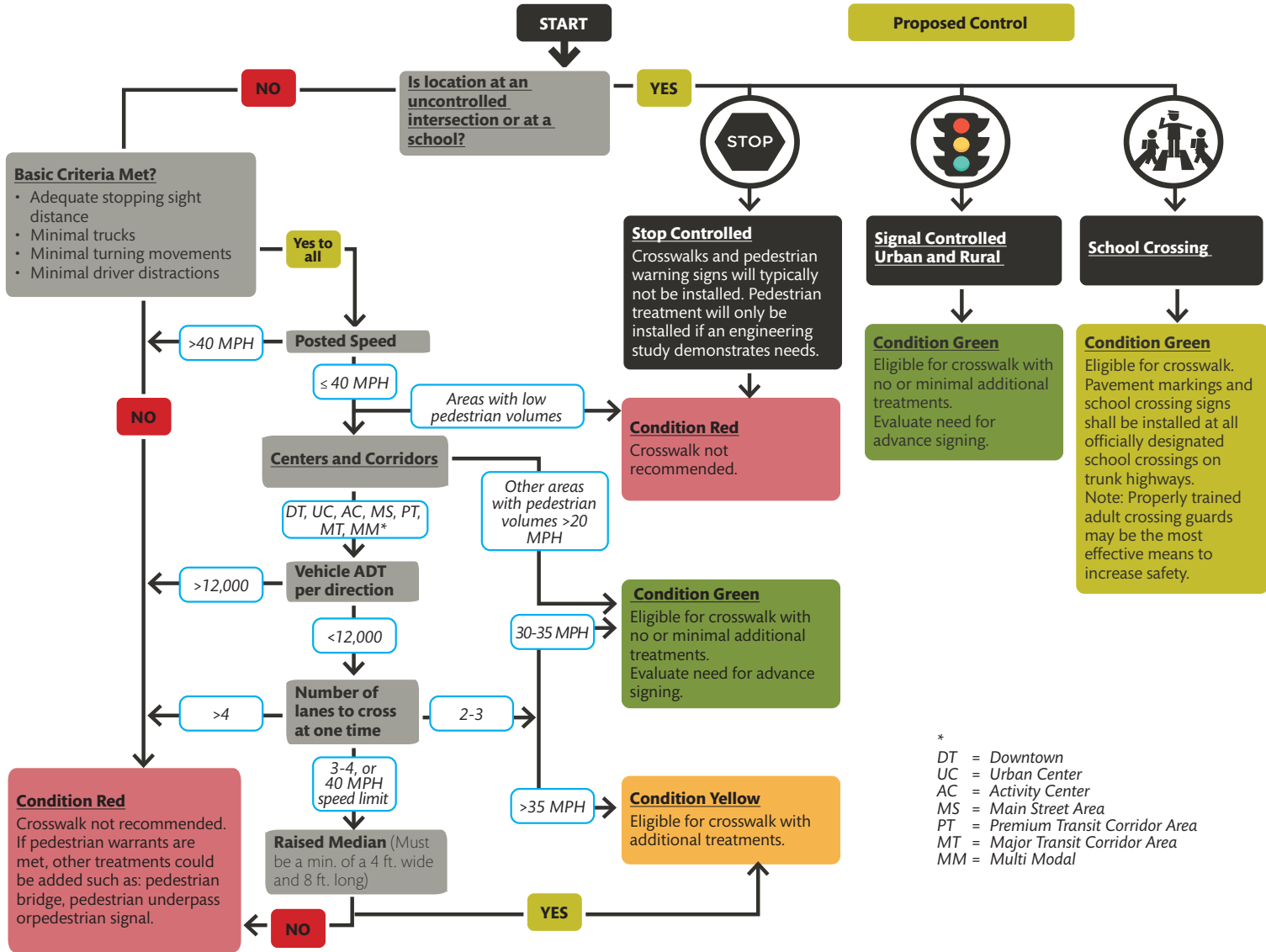

Source: NMDOT, FHWA

FIGURE 7.4.51 Pedestrian Crossing Decision Path

TABLE 7.4.43 Designated Pedestrian Crossing Types

	Controlled Locations	Traffic control device (signal or stop signs)
		Pedestrian hybrid beacon
	Uncontrolled Locations	Flashing beacon (rapid rectangular flash beacon, in-pavement flashers)
		Pedestrian refuge island
		Signage (in-street, overhead, or sign post)
		Marked crosswalk (no signs or signals)

FIGURE 7.4.52 Pedestrian Crossing Examples



7-4(A)(7)(iii) Frequency of Pedestrian Crossings

7-4(A)(7)(iii)(a) General Warranting Criteria

1. Designated pedestrian crossings shall be available between signalized crossings as appropriate and as specified in [TABLE 7.4.41](#). The frequency of designated pedestrian crossings depends on factors that include, but are not limited to the location, block length, and the type of corridor. More frequent crossings shall be provided along corridors with high levels of pedestrian activity and within Centers.
2. In locations not specified in [TABLE 7.4.41](#) (including in residential neighborhoods), the maximum distance between designated pedestrian crossings should be 1,320 feet unless there is no pedestrian activity in the area. Additional crossings may be provided as appropriate.
3. Designated pedestrian crossings should be provided at intersections unless blocks exceed desired lengths, in which case mid-block crossings may be considered. (See [Section 7-4\(A\)\(7\)\(iii\)\(d\)](#).)
4. Designated pedestrian crossings should also be provided in all of the following situations:
 - a. Within 100 feet of a transit station and 400 feet of a transit stop.
 - b. At special generators, including schools, hospitals, recreational sites, event centers, or major shopping/retail sites.
 - c. Areas with identified safety concerns, as demonstrated through a Road Safety Audit, crash rates above the regional average, or the result of other studies or data collection efforts.
5. Designated pedestrian crossings at locations other than those specified by the DPM should be supported by a study or pedestrian count information documenting that a crossing is warranted at the location.
6. Designated pedestrian crossings may be required at the discretion of the City Engineer, and may be omitted with the approval of the City Engineer.

7. Uncontrolled pedestrian crossings should not be provided in high volume traffic locations or other situations that are not conducive to safe pedestrian travel. See [Subsection 7-4\(A\)\(7\)\(iii\)\(c\)](#) for additional guidance.

7-4(A)(7)(iii)(b) Signalized Pedestrian Crossings

Signalized pedestrian crossings (e.g. traffic signals or pedestrian hybrid beacons) should be provided at intervals per [TABLE 7.4.41](#) and [TABLE 7.4.42](#) and in all of the following locations:

1. All at-grade intersections with a traffic signal.
2. Every 2,640 feet (½ mile) or less in all other circumstances, unless no pedestrian activity is present or is unlikely to be present in the future.

7-4(A)(7)(iii)(c) Considerations for Unsignalized Pedestrian Crossings

1. A decision path to determine what level of control to use at a pedestrian crossing is provided in [FIGURE 7.4.51](#). Introducing an unsignalized pedestrian crossing may make conditions less safe for pedestrians by creating a false sense of security. Unsignalized pedestrian crossings are generally discouraged.
2. Additional guidance on appropriate locations for unsignalized pedestrian crossings can be found in the [National Cooperative Highway Research Program \(NCHRP\) Report 562 Improving Pedestrian Safety at Unsignalized Crossings](#) and the [FHWA Safety Effects of Marked Versus Unmarked Crosswalks at Uncontrolled Intersections](#).
3. The City Engineer may elect not to approve the installation of an unsignalized pedestrian crossing if the location is not supported by the criteria provided in [FIGURE 7.4.51](#).

7-4(A)(7)(iii)(d) Consideration of Mid-block Crossings during Reconstruction Projects

1. Mid-block crossings shall be considered and are strongly encouraged during roadway reconstruction projects in Downtown, Urban Centers, and along Main Street Corridors where existing block lengths exceed 400 feet.
2. Mid-block crossings shall be considered and are strongly encouraged during roadway reconstruction projects where existing block lengths exceed 600 feet and where pedestrians are present, including high pedestrian activity areas such as schools.
3. Mid-block crossings are strongly encouraged where 2 major pedestrian generators are located on opposite sides of the street and are separated by a collector or arterial roadway, or to provide direct access to a school where no designated crossings are nearby.
4. The spacing of traffic signals must be evaluated during the consideration of mid-block crossings. See the [MUTCD](#) for guidance on traffic signal spacing.

Part 7-4(B) Site Access Points

Section 7-4(B)(1) Definitions

Curb returns and drivepads provide site access points for residential and commercial properties. (See [FIGURE 7.4.54](#))

1. Driveway: An area on private property where vehicles and bikes are operated or allowed to stand.

2. Drivepad: The portion of a driveway in the right-of-way that connects a street to a commercial or residential driveway and that is typically at sidewalk grade.
3. Curb Return: The curved section of curb connecting a street to an intersecting street or driveway, both of which are typically at the street grade.

FIGURE 7.4.53 Site Access Elements

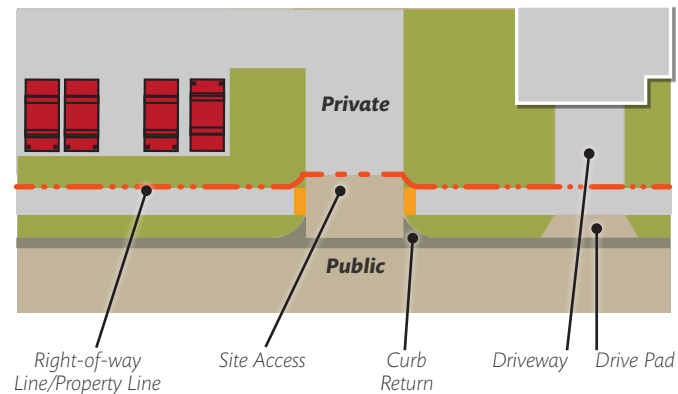

Section 7-4(B)(2) General Guidance & Curb Cuts

1. The frequency of site access points depends on the functional classification of the corridor and whether the roadway is located in a residential or non-residential area.
2. Per the [ABC Comp Plan](#), there should be minimal driveways in high pedestrian activity areas to reduce conflicts between motorists and pedestrians. Closely spaced site access points conflict with safe pedestrian movement by increasing vehicle crossings over sidewalks and by reducing on-street parking.
3. Site access points should be limited along Commuter Corridors and other auto-oriented areas in order to manage access and improve traffic flow.
4. [Part 6-5-4 Curb Cuts Ordinance \(ROA 1994\)](#) regulates the location, dimensions, and frequency of site access points along public rights-of-way.
5. Shared Site Access Points: driveways that straddle property lines, or are entirely on 1 property but are to be used by another property, shall have an access easement. Sufficient area behind the drivepad for the proper operation of the driveway must also be included.
6. Abandoned site access points: per the [Curb Cuts Ordinance](#), any abandoned site access points must be replaced with sidewalk, curb, and gutter by the property owner. As a part of a public roadway project, after 30 day notice, the City may close abandoned site accesses.
7. The driveway or intersecting road behind a curb return shall be flush with and of the same material as the paved section of the intersecting roadway.
8. Alternate materials for the site access point may be approved by the City Engineer.

Section 7-4(B)(3) Pedestrian Access

1. Pedestrian access is required to all properties in the City of Albuquerque. See [Part 7-4\(E\) Pedestrian Facilities](#) for requirements and design guidelines.

2. All site access points shall be ADA/PROWAG compliant.
3. The curb ramp and transitions shall be fully located within the City right-of-way or public sidewalk easement.
4. Right-of-way or public roadway easement is required to be dedicated as shown in [FIGURE 7.4.54](#).

FIGURE 7.4.54 Right-of-way Dedication

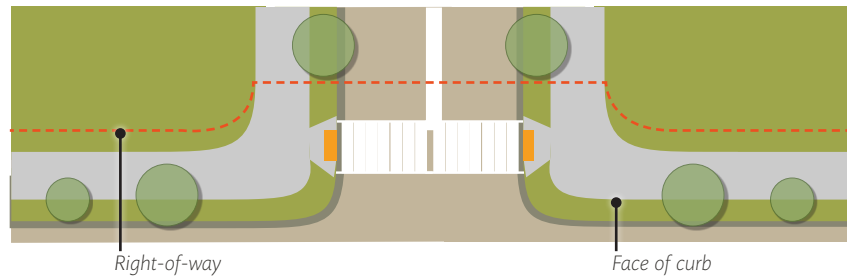

Section 7-4(B)(4) Vehicular Access

1. All site access points to City of Albuquerque roads shall be approved by the Traffic Engineer.
2. Sites are accessed through driveways or curb returns. See [Section 7-4\(B\)\(5\)](#) for locations where curb returns are allowed and the number of site access points allowed per site.
3. Site access points for low-density residential development shall be designed per [TABLE 7.4.44](#).
 - a. Illustrations for the location and dimensions of driveways and drivepads can be found in [FIGURE 7.4.55](#), [FIGURE 7.4.56](#), and [FIGURE 7.4.57](#).
 - b. The dimensions given in this section are for the width of the driveway at the drivepad / property line.
 - c. Site access points shall not be located on a major street (i.e. collector or arterial) unless it is the only street available to access the site.
 - d. For residential properties with 2 access points, driveways shall be spaced at least 28 feet apart from each other.

TABLE 7.4.44 Low-density Residential Driveways

Standards	Dimensions
Driveway width	12 ft. - 22 ft.
Minimum distance between driveways	28 ft.
Minimum distance from side property line	5 ft.
Minimum frontage for 2 driveways	60 ft.
Maximum width of shared site access point	40 ft.

FIGURE 7.4.55 Low-density Residential Driveway Location and Dimensions

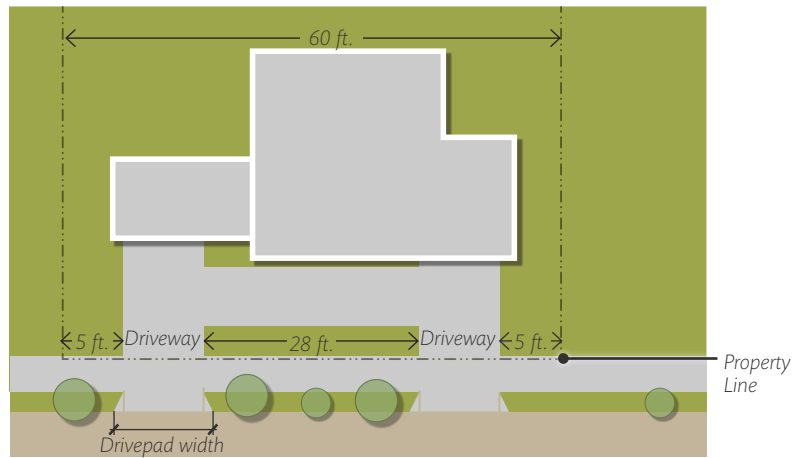

- e. Driveways shall be set back a minimum 5 feet from the side property line as illustrated in [FIGURE 7.4.55](#) and [TABLE 7.4.44](#) to ensure that the drivepad is separated from the property line sufficiently.
- f. The driveway may be built at the property line if both of the following requirements are met:
 - i. The driveway for the adjacent lot is on the far side of that lot.
 - ii. The owner presents a letter from the adjacent property owner agreeing to the location of the driveway and drivepad.
- g. Driveways located on corner properties shall be located as shown in [FIGURE 7.4.56](#). The driveway should be 25 feet from face of the curb-line extension or 10 feet from the property line extension. Whichever distance is greater from the corner governs.
- h. Driveway width may be increased to 30 feet, if requested, to allow access to a 3-car garage or to park a recreation vehicle or boat.

FIGURE 7.4.56 Driveway Distance From Intersection

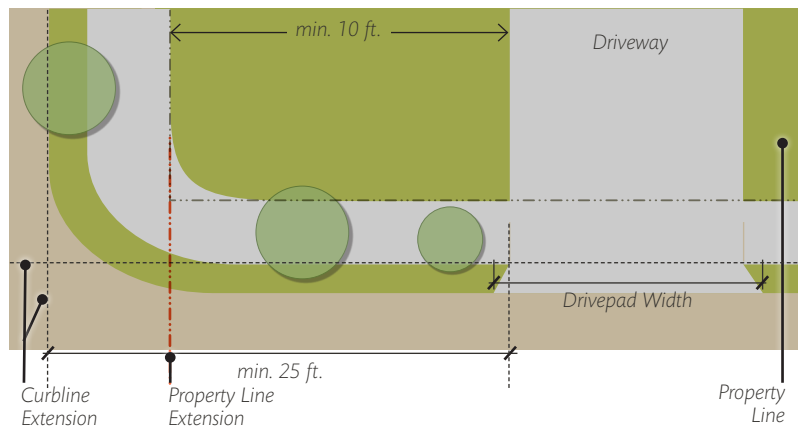

4. Shared Site Access Points

- a. For small lots (i.e. 40-foot frontage or less), the site access should be shared by 2 lots, leaving area for a minimum of 1 on-street parking space, as illustrated in [FIGURE 7.4.57](#).
- b. Shared-access driveways may be separated beyond the back of the sidewalk.
- c. The maximum width of the shared access point allowed is 40 feet.

FIGURE 7.4.57 Low-density Residential Shared Access Point

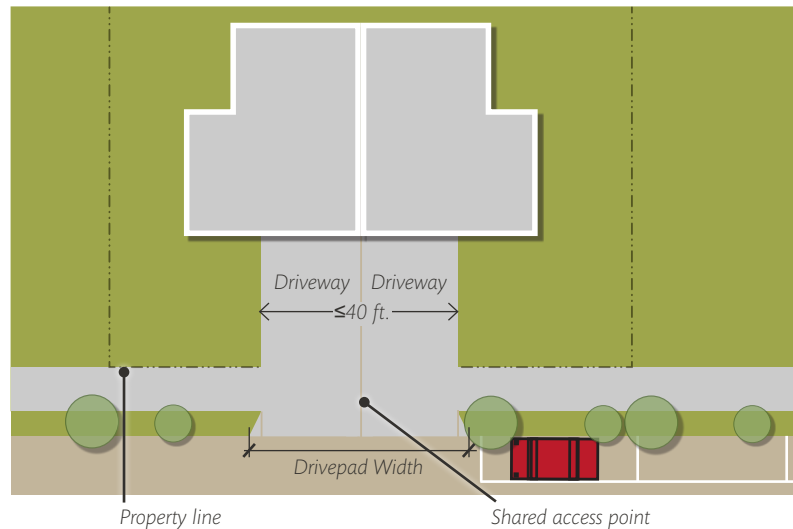

5. Multi-family, Mixed-use, and Non-residential Site Access Points
 - a. Location of site access points shall include the following considerations:
 - i. Minimum distance from an intersection, per [TABLE 7.4.45](#) and [FIGURE 7.4.58](#).
 - ii. Maximum number of site access points allowed based on roadway classification, per [TABLE 7.4.46](#).
 - b. All dimensions are measured from the curb face or driveway edge.
 - c. Site accesses should be evenly spaced in areas where more than 1 driveway is proposed for 1 site.
 - d. See [Section 7-4\(1\)\(7\) Median and Turn Lane Design](#) for additional guidance on the spacing of median openings.

FIGURE 7.4.58 Commercial Site Access Points and Distance From

Intersection

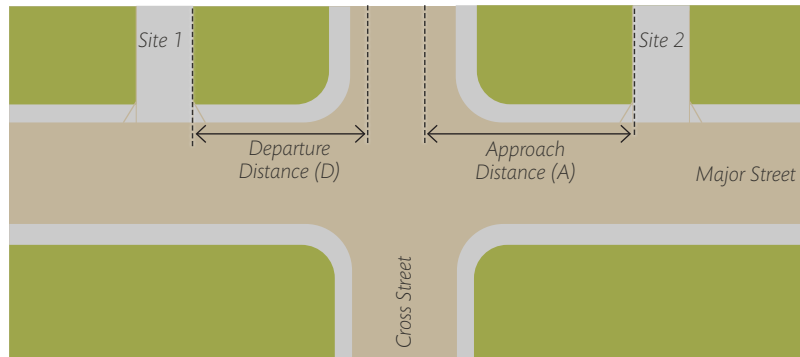

TABLE 7.4.45 Minimum Distance Between Commercial Site Access and Intersection

Type of Street	Cross Street Classes					
	Arterial		Collector		Local	
	A	D	A	D	A	D
Principal Arterial	300 ft.	200 ft.	200 ft.	150 ft.	150 ft.	100 ft.
Minor Arterial	200 ft.	150 ft.	150 ft.	100 ft.	100 ft.	100 ft.
Major Collector	150 ft.	150 ft.	100 ft.	100 ft.	75 ft.	75 ft.
Minor Collector	150 ft.	150 ft.	100 ft.	100 ft.	75 ft.	75 ft.
Local (additional distance may be required for queuing)	75 ft.	75 ft.	50 ft.	50 ft.	25 ft.	25 ft.

TABLE 7.4.46 Maximum Number of Commercial Site Access Points per Site

Type of Street	
Principal Arterials	1-2 access points per 300 ft. frontage
Minor Arterials	1-2 access points per 200 ft. frontage
Collectors	1 access point per 100 ft. frontage

Section 7-4(B)(5) Curb Return Design

7-4(B)(5)(i) Curb Return Access Guidelines

1. Curb returns rather than drivepads are recommended on collectors and arterials and may be appropriate under any of the following circumstances:
 - a. For high-volume traffic generators (e.g. over 25 vehicles entering or exiting per hour).
 - b. For developments with median access and 25 or more parking spaces.
 - c. For developments with 50 or more required parking spaces.
2. Curb returns are permitted on local streets when a site has more than 50 parking spaces.

3. One-way drives are only permitted where the circulation is self-enforcing (e.g. when angle parking and one-way aisles are used to establish the one-way pattern from entrance to exit).
4. The width and radius of the entrance are dependent upon the design vehicle. The design vehicle is generally an SU-30, though a smaller design vehicle is encouraged where feasible. See [Section 7-4\(I\)\(6\) Intersection Design](#) for additional information.

7-4(B)(5)(ii) Curb Return Access Widths

1. Widths of site access points shall be per [TABLE 7.4.47](#).
2. Additional width may be permitted for median. See [FIGURE 7.4.60](#) and [FIGURE 7.4.61](#) for typical curb return access layout.
3. Narrower site access points shall be provided in Centers; along Premium and Major Transit, Multi-modal, and Main Street Corridors; and in locations with high pedestrian activity levels.

TABLE 7.4.47 Driveway Widths for Arterial, Collector, and Local Streets

Entrance	Arterial & Collector	Local Streets
One-way Drive	20 ft. - 25 ft.	12 ft. - 20 ft.
Two-lane Drive	22 ft. - 30 ft.	22 ft. - 24 ft.
Three-lane Drive	24 ft. - 35 ft.	22 ft. - 30 ft.
Larger Vehicles (WB-40 or larger)	Max 50 ft.	Max 30 ft.

FIGURE 7.4.59 Curb Return Access Point

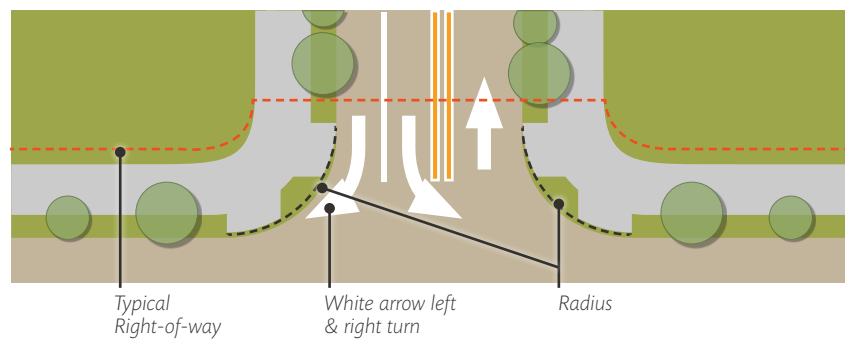
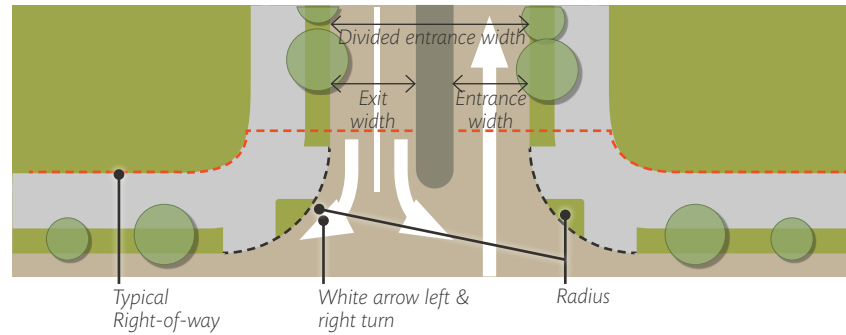

FIGURE 7.4.60 Divided Entrance Width



7-4(B)(5)(iii) Curb Return Access Radii

1. Curb radii shall be designed according to the standards in [TABLE 7.4.48](#).
2. Additional curb return radii guidance provided in [Section 7-4\(1\)\(6\)\(iii\)](#).
3. Smaller radii shall be provided in Centers; along Premium and Major Transit, Multi-modal, and Main Street corridors; and in locations with high pedestrian activity levels. Coordinate with City Engineer for use of smaller radii.

TABLE 7.4.48 Curb Return Radii by Design Vehicle – Single Entrance/Exit Widths

Design Vehicle	Max. Radius at Flow Line
Car Only	15 ft.
SU-30 (Single-unit truck: 30 ft./wheel base: 20 ft. (refuse truck))	25 ft.
WB-40 (Tractor trailer: 50 ft./wheel base: 40 ft.)	30 ft.
WB-50 (Tractor trailer: 55 ft./wheel base: 50 ft. (18-wheeler))	35 ft.

Section 7-4(B)(6) Access Control

1. See the [MRCOG Roadway Access Control Inventory of Limited Access Roadways](#) for locations where site access may be limited. Contact the Traffic Engineer in the Transportation Development Division or visit the [MRCOG website](#) for additional information.
2. Limited-access roadways are typically located on principal arterials or on the interstate/frontage road system. This restriction may apply to the entire roadway length or individual segments.
3. Where drivepads/access points are to be constructed on opposite sides of the street, the centerlines need to be as closely aligned as conditions allow. (See [FIGURE 7.4.61](#).) Drivepads/access points do not need to be aligned if they are offset by 50 feet or more.
4. Where a median opening is desired, access to both sides of the street shall be considered. If development exists on both sides of the street, left turn bays for both directions may need to be constructed. For streets with

- medians, access points need to be placed such that the centerline of the driveways/access points are as closely aligned as conditions allow on the median openings.
5. Streets or driveways with median access points shall be placed such that the centerline of the access points are as closely aligned as conditions allow on the median openings.
 6. If access points cannot be aligned, it is recommended to have them offset so that potential left turn paths do not cross and requirements are met for Case F Sight Distance in the [AASHTO Green Book](#).

FIGURE 7.4.61 Non-residential Driveways with Aligned Centerline

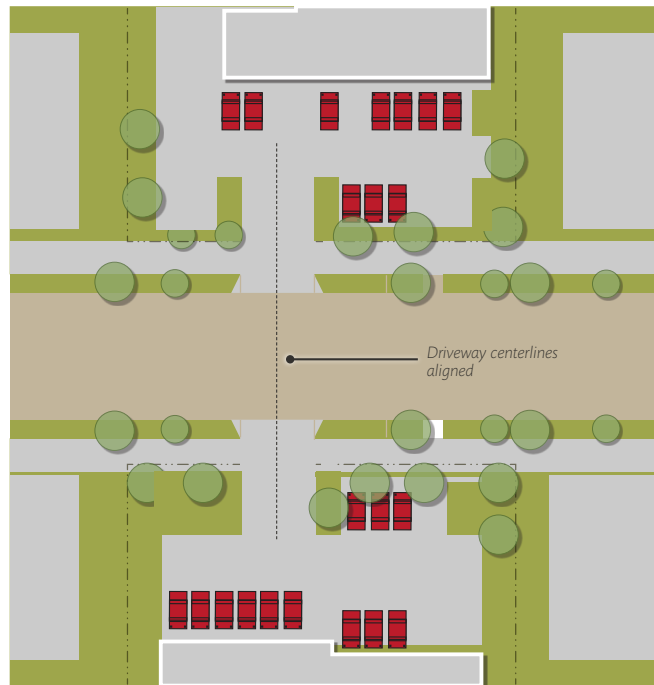

Section 7-4(B)(7) Striping and Signage

1. Site access points with 3 or more lanes require striping and arrows to define proper usage by entering and exiting vehicles. See [City Standard Specifications](#) and the latest [MUTCD](#) for additional information.
2. Appropriate signage needs to be included with the construction of any commercial site access point. This may include one way, exit, entrance, and turn restriction signs.

Section 7-4(B)(8) Roadways in NMDOT Jurisdiction

A driveway permit from the District 3 office is required for roadways under NMDOT jurisdiction, in addition to City concurrence. To learn the boundaries for NMDOT roadways, contact the Traffic Engineer.

Part 7-4(C) Pavement Design

Section 7-4(C)(1) General Provisions

The sections in [Part 7-4\(C\)](#) provide requirements for the subgrade materials evaluation, traffic analysis, and design of flexible pavements, rigid pavements, and alternative pavements. Either the methods below or the design procedure from the NMDOT are acceptable for design of pavements in the city.

The design method contained herein was developed by the review of various methods that are now, or have been, in use by different state transportation departments and/or municipalities within the southwestern United States. These methods are all based on adoption and enhancement of the [AASHTO 1993 Guide for Design of Pavement Structures](#). These methods were selected due to history of performance and due to the City of Albuquerque being in a specific geographic location where experience can be called upon and certain factors will not change.

The 3 major overall assumptions that have been made in the development of these design procedures are:

1. The adequacy of the design will be established by soils and material surveys and laboratory studies.
2. The design strengths assumed for the subgrade and pavement structure will be achieved through proper construction methods.
3. An adequate present and projected traffic loading for the analysis period is derived from accurate present and historical data in order to achieve the intended serviceability of the roadway.

Section 7-4(C)(2) Subgrade Materials Evaluation

7-4(C)(2)(i) Sampling Methods

The City of Albuquerque uses all of the following sampling methodology for subgrade material evaluation:

4. The R-value test is the means of obtaining a resilient modulus for use in the [AASHTO 1993 Guide for Design of Pavement Structures](#) design equation for flexible pavements.
5. The correlation between R-value and resilient modulus is in [TABLE 7.4.49](#).
6. All soil tests shall be conducted under the supervision of a professional engineer registered in the State of New Mexico familiar with soil sampling and testing procedures.
7. The design subgrade soil is defined as the upper 2 feet of soil under the proposed pavement.

7-4(C)(2)(ii) Frequency of Testing and Required Elements

All of the following sampling frequency and techniques for subgrade materials (native and borrowed) shall be used:

1. One (1) sample for each type of soil.
2. A minimum of 1 sample every 300 feet for collector and arterial streets.
3. A minimum of 2 samples per project minimum.

4. One (1) "R" value and proctor sample per each soil condition or 3 per mile of the poorest soil.
5. At least 1 and preferably 2 soil borings should go down to a depth comparable to any potential sewer or water line depth. A moisture determination should be made for each sample.
6. Sampling is to be random and shall not be restricted along any given line, but shall be spread irregularly over the proposed roadway.
7. The depth of sampling shall extend to a minimum depth of 3 feet below proposed subgrade elevation unless rock is encountered.

7-4(C)(2)(iii) Required Soil Tests

All of the following tests shall be performed on all soil samples:

1. Sieve analysis.
2. Plastic index.
3. Soil correlation/analysis to determine representative soils, on which R-value tests are to be performed.
4. With approval from the City Engineer, the designer can use R-value from [TABLE 7.4.49](#) based on soil type to supplement actual R-value test results on the subgrade soils encountered. Both the tested and estimated R-values can be used to determine the design R-value.
5. R-value and Proctor density-moisture tests.
6. If subgrade stabilization will be used, stabilization testing is required.
7. Determination of in-situ moisture content.

7-4(C)(2)(iv) Geotechnical Design Report

1. Pavement designs for local streets serving residential areas have been standardized and are presented in Section 2400 of the [City Standard Specifications](#). These standards are based on an R-value of 50 or greater. Soils investigation as outlined in this section will be required to determine the nature of subgrade treatment needed to achieve the minimum R-value.
2. A design report shall be submitted for the construction of arterial, collector, or streets located in industrial areas. This report documents the existing pavement section material, thickness, and width and considers the design information regarding the proposed improvements. Any unusual circumstances that could affect design and/or construction shall be noted. A site plan showing boring locations, soil boring logs and soil test results shall be provided.
3. The design "R" value is correlated to the Resilient Modulus (MR) for use in the flexible pavement design nomograph using [TABLE 7.4.49](#).

TABLE 7.4.49 R-value and Resilient Modules (M_r) Correlation

R-VALUE	MR	R-value	MR	R-value	MR
0	2176	30	6143	60	17345
1	2252	31	6359	61	17956
2	2331	32	6583	62	18588
3	2414	33	6815	63	19242
4	2499	34	7055	64	19920
5	2586	35	7303	65	20621
6	2678	36	7560	66	21347
7	2772	37	7826	67	22098
8	2869	38	8102	68	22876
9	2970	39	8387	69	23682
10	3075	40	8682	70	24515
11	3183	41	8988	71	25379
12	3295	42	9305	72	26272
13	3411	43	9632	73	27197
14	3531	44	9971	74	28154
15	3656	45	10322	75	29146
16	3784	46	10686	76	30172
17	3918	47	11062	77	31234
18	4056	48	11451	78	32334
19	4198	49	11854	79	33472
20	4346	50	12272	80	34650
21	4499	51	12704	81	35870
22	4658	52	13151	82	37133
23	4822	53	13614	83	38440
24	4991	54	14093	84	39794
25	5167	55	14590	85	41194
26	5349	56	15103	86	42645
27	5537	57	15635	87	44146
28	5732	58	16185	88 and higher	45700
29	5934	59	16755		

Section 7-4(C)(3) Traffic Factors in Pavement Design

7-4(C)(3)(i) Traffic Criteria for Pavement Design

1. Average weekday daily traffic (AWDT), street classification, percent distribution of vehicle types, directional distribution, and the growth rate used for the design computations shall be obtained either from MRCOG or through a traffic study conducted by a professional engineer registered in the State of New Mexico. The values shall be compared against those in

[TABLE 7.4.50](#), and, unless the values are based on historical data more than 5 years old, the greater value shall be used.

Street Classification	AWDT (both directions)	Truck Traffic Percentage*				Directional Distribution	Annual Growth Rate
		SUT	STT	MTT	Bus		
Principal Arterial	12,000	3	1	1	*	50%	5%
Minor Arterial	8,500	3	1	1	*	50%	4%
Collector	6,000	3	1	1	*	50%	4%

* SUT = Single-unit Truck; STT = Single-trailer Truck; MTT = Multi-trailer Truck. For buses, contact City Transit Department.

- On smaller projects (less than 1,000 linear feet of street construction), where traffic count data is not available and a traffic count study is not warranted, the values in [TABLE 7.4.50](#) may be used, as approved by the City Engineer.
- Pavement shall be designed for 20 years unless approval for an alternate design life is received from the City Engineer.
- The growth factor values to be used for calculations in this section are identified in [TABLE 7.4.51](#).

Design Period Years	Annual Growth Rate							
	No Growth	2%	4%	5%	6%	7%	8%	10%
1	1	1	1	1	1	1	1	1
2	2	2.02	2.04	2.05	2.06	2.07	2.08	2.1
3	3	3.06	3.12	3.15	3.18	3.21	3.25	3.31
4	4	4.12	4.25	4.31	4.37	4.44	4.51	4.64
5	5	5.2	5.42	5.53	5.64	5.75	5.87	6.11
10	10	10.95	12.01	12.58	13.18	13.82	14.49	15.94
15	15	17.29	20.02	21.58	23.28	25.13	27.15	31.77
20	20	24.3	29.78	33.06	36.79	41.00	45.76	57.28
25	25	32.03	41.65	47.73	54.86	63.25	73.11	98.35
30	30	40.57	56.08	66.44	79.06	94.46	113.28	164.49
35	35	49.99	73.65	90.32	111.43	138.24	172.32	271.02

* Growth Factor= $((1+r)^n)/r$ where r =rate/100 and is not 0.

- The ESAL Vehicle Equivalency Factor (EF) for various vehicle types are as shown in [TABLE 7.4.52](#).

TABLE 7.4.52 ESAL Vehicle Equivalency Factor

Vehicle Type	ESAL EF
Passenger Car	0.0008
Other 4-wheel vehicle	0.0087
Single Unit Truck	0.1890
Single-trailer Truck	2.3719
Multi-trailer Truck	2.3187
Bus	0.6808

6. The following equation will calculate the default ESAL (18,000-pound Equivalent Single Axle Load):

$$\text{EQUATION 7.1 } \text{ESAL} = \text{AWDT} \times 365 \times \text{Growth Factor} \left(\frac{\% \text{SUT} \times \text{EF}_{\text{SUT}} + \% \text{STT} \times \text{EF}_{\text{STT}} + \% \text{MTT} \times \text{EF}_{\text{MTT}} + \% \text{Bus} \times \text{EF}_{\text{Bus}} + \% \text{Auto} \times \text{EF}_{\text{Auto}}}{100} \right)$$

For this calculation, the sum of the different vehicle types equals 100%, and the percentage is entered numerically. For example, 3% is entered as .03.

7-4(C)(3)(ii) Design Lane Traffic Computation

The following equation will determine the ESAL in the design lane:

$$\text{EQUATION 7.2 } \text{ESAL}_L = D_d \times D_L \times \text{ESAL}$$

where:

- D_d = A directional distribution factor, expressed as a percentage, that accounts for the distribution of ESAL units by direction but not less than what is shown in [TABLE 7.4.50](#).
- D_L = A lane distribution factor, expressed as a percentage, that accounts for distribution of traffic when 2 or more lanes are available in one direction ([TABLE 7.4.53](#)).

TABLE 7.4.53 Lane Distribution Factor, DL

No. of Lanes in Each Direction	Percent ESAL in Design Lane
1	100
2	90
3	70
4	65

7-4(C)(3)(iii) Example ESAL Calculation

Example for a 4-lane minor arterial:

$$\text{ESAL} = 8,500 \times 365 \times 29.78 [(0.03 \times 0.1890) + (0.01 \times 2.3719) + (0.01 \times 2.3187) + (0.95 \times 0.0008)] = 4,927,844$$

$$\text{ESAL}_L = 0.5 \times 0.9 \times 4,927,844 = 2,217,530$$

Section 7-4(C)(4) Structural Design of Pavement

7-4(C)(4)(i) Minimum Pavement Component Thickness

The criteria in [TABLE 7.4.54](#) govern minimum pavement component thickness and apply to all major (arterial and collector) roadways. These criteria are derived based on engineering judgment and past experience in construction quality control.

TABLE 7.4.54 Minimum Pavement Component Thickness	
Pavement Component	Minimum Thickness
Asphaltic Concrete (AC)	4 in.
Cement-Treated Base Course (CTB)	4 in.
Bituminous Treated Base Course (BTB)	4 in.
Aggregate Base Course (ABC)	4 in.
Sub-base Material	4 in.
Soil Cement	6 in.
Asphalt Emulsion Treated Soil	6 in.

7-4(C)(4)(ii) Structural Coefficients of Pavement Components

TABLE 7.4.55 Structural Coefficients of Pavement Components		
Pavement Component	Layer Modification Factor	Structural Coefficient
Plant Mix Seal Coat (PMSC)	N/A	0.25
Asphaltic Concrete (AC)	N/A	0.42
Bituminous Treated Base Course (BTB)	N/A	0.25
Cement Treated Base Course (CTB)	N/A	0.20
Aggregate Base Course (ABC)	1.15	0.10
Sub-base Material	1.00	0.06
Asphalt Emulsion Treated Soil	N/A	Tentative
Soil Cement	N/A	Tentative
Lime Stabilization	N/A	Tentative

The design structural number is calculated using the layer modification factors and structural coefficients in [TABLE 7.4.55](#) and all of the following steps:

1. The layer modification factor is applied to the base course layer coefficient to reflect the drainage or permeability characteristics of the selected base course.

2. Drainage coefficients are not applied to the asphaltic concrete layers, nor to the stabilized subgrade layers.
3. The modification factors may be set to other values than those recommended if the designer chooses.
4. The modification factors will range between 1.00 and 1.15 for bases approaching saturation less than 25% of the time, and base permits water removal within 1 day.
5. If the stated conditions do not apply, see Part 2, Section 2.4 of the [AASHTO 1993 Guide for Design of Pavement Structures](#).
6. The structural number is calculated using the depth in inches (di) for each layer as follows:

$$\text{EQUATION 7.3 } \mathbf{SN} = a_1 d_1 + a_2 d_2 m_2 + \dots + a_i d_i m_i$$

7-4(C)(4)(iii) Serviceability Index

The serviceability of a pavement is defined as the ability to serve high-volume automobile and truck traffic. In the design equation, the serviceability index enters into the equation as the lowest index that will be tolerated before resurfacing or reconstruction becomes necessary.

A scale with a range of 0 through 5 was established for present serviceability rating, with a value of 5 as the highest index of serviceability and 0 as the lowest. The initial serviceability (Po) rating and terminal serviceability (Pt) rating are recommended to be selected as shown in [TABLE 7.4.56](#).

Street Classification	Initial Serviceability Rating (p _o)	Standard Normal Deviation (P _t)
Principal Arterial	4.2	2.5
Minor Arterial	4.2	2.0
Collector	4.2	2.0

* Based on the 1993 AASHTO method of calculating ESAL's (change in PSI = P_o - P_t).

7-4(C)(4)(iv) Reliability and Statistics

The 1993 AASHTO method of calculation incorporates reliable statistics on the degree of certainty for expected performance over the 20 year analysis period. [TABLE 7.4.57](#) provides the 1993 AASHTO equation recommended reliability and standard deviation values for principal arterial, minor arterial, and collector streets.

Street Classification	Reliability Level	Standard Deviation (S _o)	Standard Normal Deviation (Z _R)
Principal Arterial	85%	0.45	-1.037
Minor Arterial	80%	0.40	-0.841
Collector	75%	0.40	-0.674

Alternatively, the standard normal deviation as a function of reliability level may be chosen as from [TABLE 7.4.58](#). It is not recommended to use a design reliability level of greater than 90%.

TABLE 7.4.58 Standard Normal Deviation Values	
Reliability Level	Standard Normal Deviation (Z_R)
50%	-0.000
60%	-0.253
70%	-0.524
75%	-0.674
80%	-0.841
85%	-1.037
90%	-1.282

7-4(C)(4)(v) Economic Factors

The design engineer is encouraged to investigate the use of various combinations of pavement components in order to derive the most economic design applicable to the project characteristics and structural requirements.

Section 7-4(C)(5) Flexible Pavements Design

7-4(C)(5)(i) Design Procedure

1. A nomograph from the [AASHTO 1993 Guide for Design of Pavement Structures](#) pavement design has been provided to simplify the solution to the mathematical relationship of the Resilient Modulus value, ESAL, and the structural number. (See [FIGURE 7.4.62](#).)
2. Pavement structural designs shall be submitted in the format as shown on [TABLE 7.4.59](#).
3. The equation for calculation of ESAL (W18) using the [AASHTO 1993 Guide for Design of Pavement Structures](#) is shown below:

$$\text{EQUATION 7.4 } \log_{10} W_{18} = Z_R S_o + 9.36 \log_{10} (SN + 1) - 0.2 + \frac{[(\log_{10} [\text{change in PSI}/(4.2-1.5)]) / (0.40 + [1094/(SN+1)^{5.19}])]}{2.32 \log_{10} M_R} - 8.07$$

FIGURE 7.4.62 Design Chart Flexible Pavements

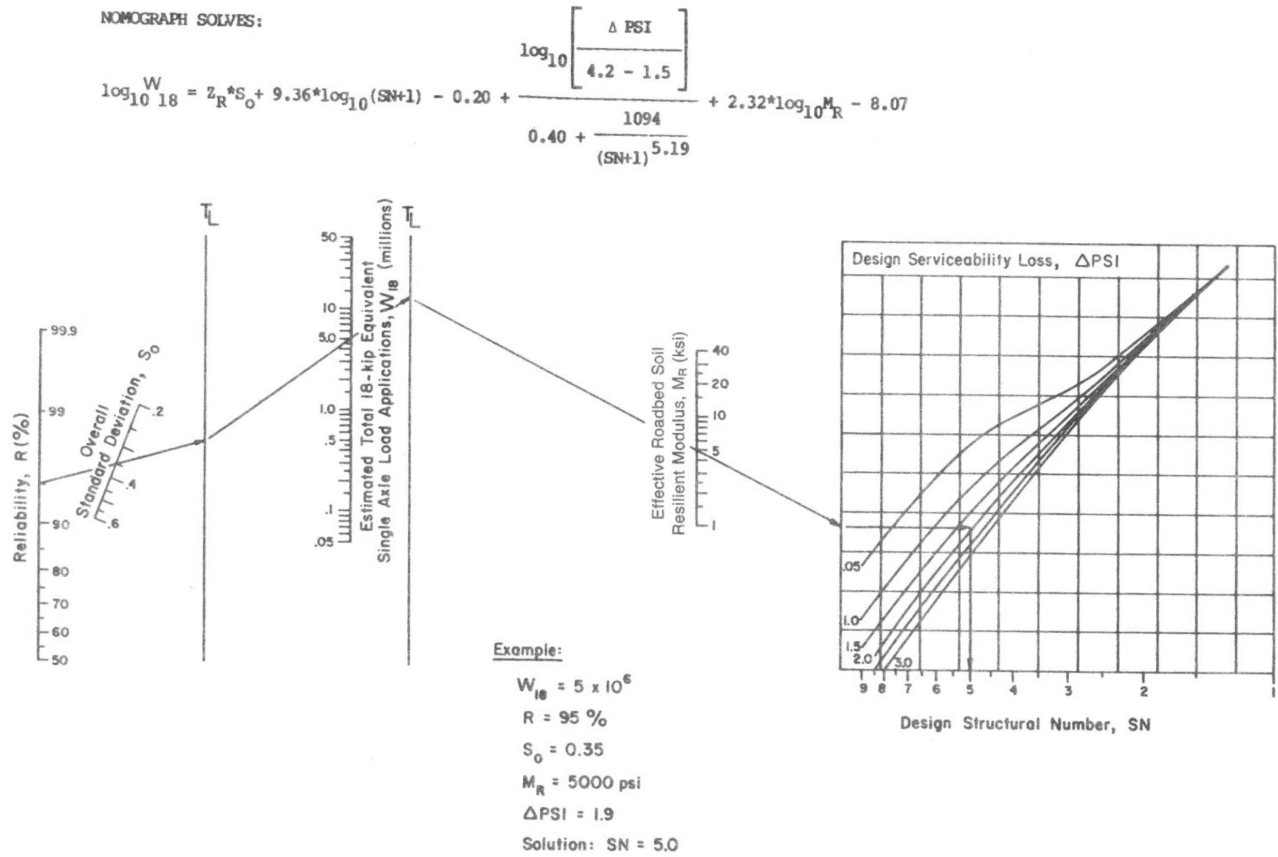

Design Chart for Flexible Pavements Based on Using Mean Values for Each Input

TABLE 7.4.59 Structural Design Computation Form

PROJECT NAME: _____ STREET: _____
 PROJECT NO: _____ FROM: _____
 DESIGN ADL: _____ TO: _____
 DESIGN SN: _____ COMPUTED BY: _____

Alternate	Subbase	CTB	BTB	ABC	AC	PMSC	SN
A	x(0) =	x(2) =	x(25) =	x(1) =	x(42) =	x(25) =	
B							
C							
D							
E							
F							

Design SN _____

Section 7-4(C)(6) Portland Cement Concrete Design

The current acceptable method for design of Portland cement concrete pavement is the procedure in the [AASHTO 1993 Guide for Design of Pavement Structures](#) and [1998 Supplement - Guide for Design of Pavement Structures, Part II](#). As an alternative, the Portland Cement Concrete Pavement (PCCP) design may be determined by use of accepted industry approach and software, such as the American Concrete Pavement Association “Street Pave” software or NMDOT procedures. Concrete pavement joints shall be detailed in the plans. Guidelines for joint layout can be obtained from the [American Concrete Pavement Association](#).

All of the following design criteria shall be used in the structural design of PCCP:

1. All PCCP shall be fly-ash modified concrete as specified in the [City Standard Specifications](#) or have other methods of mitigating Aggregate Silica Reaction as approved by the City Engineer.
2. Design of PCCP shall be based on flexural strength value of 600 psi at 28 days as measured by ASTM Method C 78.
3. Stabilized base course values used in conjunction with PCCP designs shall be as indicated below:
 - a. *Portland Cement Stabilized Base: 300 psi compressive strength as measured by ASTM Method D1633.*
 - b. *Asphalt Treated Base: 1,000 pound minimum Marshal stability as measured by ASTM Method D1559 (as modified in the [City Standard Specifications](#)).*
4. Reliability shall be 85%.
5. Final Serviceability Index shall be 2.5.

Section 7-4(C)(7) Alternative Pavement

1. Alternative types of pavement can be used for crosswalks, parking lots, sidewalks, and trails.
2. Where used in the City right-of-way, approval of proposed design and City's maintenance obligations are required from the City Engineer and the Department of Municipal Development.
3. Alternative materials must have sufficient strength for the projected traffic and require approval of the City Engineer.
4. Crosswalks may be a different material from the remainder of the street.
5. Options for alternative pavement include but are not limited to:
 - a. *Brick*
 - b. *Pavers*
 - c. *Permeable or Porous Pavement*
 - d. *Stamped Concrete*
 - e. *Gravel*

7-4(C)(7)(i) Permeable or Porous Pavement

Requests to use permeable pavement shall include all of the following:

1. Geotechnical investigation showing that the subgrade soils have sufficient percolation properties or a design that provides rainwater storage until percolation is achieved.
2. Agreement to maintain the pavement using sweeping, vacuuming or power washing.

3. Product information showing that the porous pavement meets [ADA](#) requirements. If it does not, a different material that does meet those requirements must be used for ADA accessible parking spaces and any accessible paths, and documentation must be provided.

Part 7-4(D) Curb and Gutter

Section 7-4(D)(1) Right-of-way Requirements

1. All streets within the City shall have curb and gutter. Exceptions may be granted by the City Engineer in developed areas that predominantly lack curb and gutter and existing right-of-way widths are insufficient to add them.
2. On collectors and above, the standard 8 inch high barrier-type curb as shown in the [City Standard Specifications](#) must be used as the exterior curb section. Deviation from these standards will require approval of the City Engineer.
3. On local streets, 6 inch high barrier-type curb is the standard curb to be used for the exterior curb section; however, 8 inch high barrier-type curb may be used to accommodate drainage requirements as needed.
4. If both traffic and drainage requirements can be met to the satisfaction of the City Engineer, mountable curb types as shown in the [City Standard Specifications](#) may be used on local streets.
5. Mountable curbs may be used in roundabout and/or traffic circle medians.
6. On collectors and above, a 1.5 foot wide gutter pan shall be installed at all curb locations.
7. On local streets, a 1.5 foot wide gutter pan may be installed at all curb locations. Wider gutters may be used to accommodate drainage requirements.
8. The gutter pan is considered as a part of the overall roadway width; it may be included as part of the width of the curbside travel lane and on-street parking space. The gutter pan is not included as a part of the required width of a bicycle lane.

Section 7-4(D)(2) Private Property Requirements

1. A visual barrier must be maintained along the public street clearly defining the points of access. Curbs shall be used in conjunction with landscaping as required by the [IDO](#).
2. Curbs should be used to separate landscaping from parking areas and pedestrian ways in non-single-family residential developments.
3. Curbing or parking blocks should be provided to prevent overhang of parking stalls or circulation of vehicles over sidewalk or City right-of-way.

Part 7-4(E) Pedestrian Facilities

The [ABC Comp Plan](#) emphasizes the provision of a range of safe travel options, including access for pedestrians to all areas of the metropolitan area. As such, all public and private transportation facilities shall include pedestrian appropriate accommodations.

Section 7-4(E)(1) **Public Sidewalks**

7-4(E)(1)(i) **General Provisions**

1. All roads in the City right-of-way or roadway easements shall include distinct and accessible pedestrian accommodations. Alleyways are exempt from the requirement for separate pedestrian accommodations.
2. All new roadway construction shall include sidewalks and landscape/buffer zones installed on both sides of the street.
3. Roadway reconstruction, defined in this section as any project that includes the construction of new curbs or the horizontal relocation of the curb line, shall include sidewalks and landscape/buffer zones to the greatest extent feasible.
4. Additional right-of-way or easements may be required if any portion of the sidewalk is located outside the existing right-of-way.
5. High pedestrian activity areas are defined as Centers, Main Street Corridors, and Premium Transit station areas, as well as areas surrounding big box stores or clusters of retail activity, school zones, locations where buildings with zero setback are present, and neighborhoods with an average density of 10 units per acre. Multi-modal and Major Transit Corridors may also be considered high pedestrian activity areas depending on the surrounding land uses.
6. If a proposed public sidewalk is located along a Corridor and has constrained right-of-way, the designer should consult the [ABC Comp Plan](#) Table 7-5: Priority Street Element Matrix to identify priority elements.
7. Exceptions to sidewalk and width requirements may be granted in historic neighborhoods, where sidewalks have traditionally not been present, or to match the surrounding character of the residential area. Waivers may be granted by the City Engineer within developed areas that predominantly lack sidewalk and where existing right-of-way widths are insufficient to add them.
8. DPM waiver procedures are found in [Article 2-9 DPM Waiver](#) in [Chapter 2 Development Procedures](#).

7-4(E)(1)(ii) **Pedestrian Realm Typologies**

See [Part 7-2\(D\) Street Elements](#) for pedestrian realm definitions. Below are the graphic configurations of the pedestrian realm.

7-4(E)(1)(ii)(a) Residential Areas

FIGURE 7.4.63 Residential Area

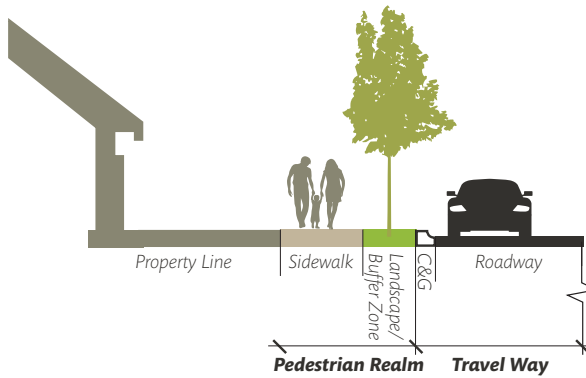

7-4(E)(1)(ii)(b) Mixed-use Areas

FIGURE 7.4.64 Mixed-use Area

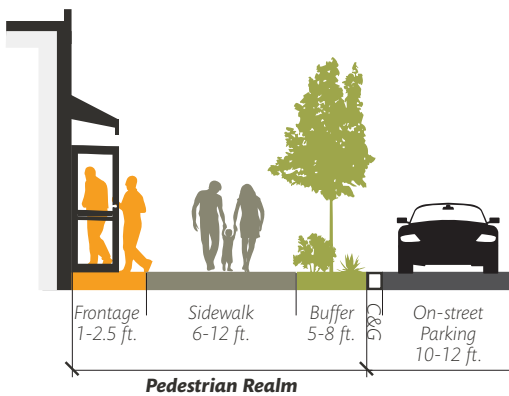

7-4(E)(1)(iii) Pedestrian Facility Dimensions

1. See [TABLE 7.2.29](#) for design requirements for pedestrian facilities and other roadway elements by location and functional class. See [Part 7-4\(J\) Local Streets](#) for additional guidance on pedestrian facilities on local roadways.
2. All sidewalks on new and reconstructed roadways shall provide a minimum 5 foot wide pedestrian access route.
3. Wider sidewalks shall be provided in Centers; along Premium and Major Transit, Multi-modal, and Main Street Corridors; and in locations with high pedestrian activity levels per [TABLE 7.2.29](#).
4. If right-of-way is constrained and there is insufficient space for a landscaping buffer, the sidewalk should be widened an additional 2 feet. This extra width is used to provide additional pedestrian circulation and comfort and to create separation from transit service running in curbside lanes, while also serving the various roles of the landscape/buffer zone.

7-4(E)(1)(iv) Frontage Zone

1. A frontage zone is not required for development in residential and non-residential zone districts where large front setbacks apply.
2. The frontage zone is encouraged for development in mixed use zones, particularly in areas with setback maximums, with overhead awnings and signs projecting over the sidewalk, in Downtown and Urban Centers, and along Premium Transit and Main Street Corridors.

7-4(E)(1)(v) Sidewalk Design Requirements

1. Sidewalks and curb ramps shall be a minimum of 4 inches thick Portland cement concrete as shown in the [City Standard Specifications](#). Designs incorporating alternate materials must be approved by the Design Review and Construction Section (DRC). The basis for consideration of such approval will be appropriateness, safety, and durability resulting in a useful life expectancy near or equal to that of the standard Portland cement concrete sidewalks.
2. All new sidewalks shall meet or exceed ADA/PROWAG requirements. Reconstruction projects including sidewalks and ramps shall be brought into conformity with ADA/PROWAG standards to the maximum extent possible.
3. Sidewalk cross slopes shall not exceed 2%. To ensure ADA/PROWAG compliance, it is recommended that cross slopes be designed at 1.5% to allow for tolerance in construction. (See [FIGURE 7.4.65](#).)
4. The sidewalk running slopes shall have a maximum grade of 5% unless the existing grade of the roadway exceeds 5%. In which case the sidewalk may match but not exceed the general grade established by the adjacent roadway or right-of-way easement. (See [FIGURE 7.4.65](#).)

FIGURE 7.4.65 Sidewalk Slopes

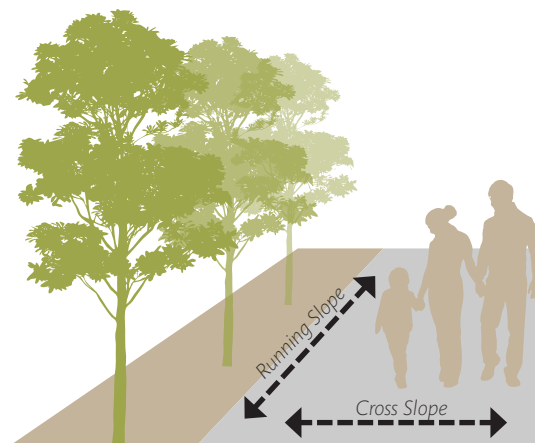

5. If it is necessary to locate objects such as mailboxes, hydrants, signposts, etc. within a sidewalk, then the sidewalk shall be widened to provide a minimum pedestrian access route of 4 feet around any part of the obstruction. (See [FIGURE 7.4.66](#).)

FIGURE 7.4.66 Pedestrian Access Route

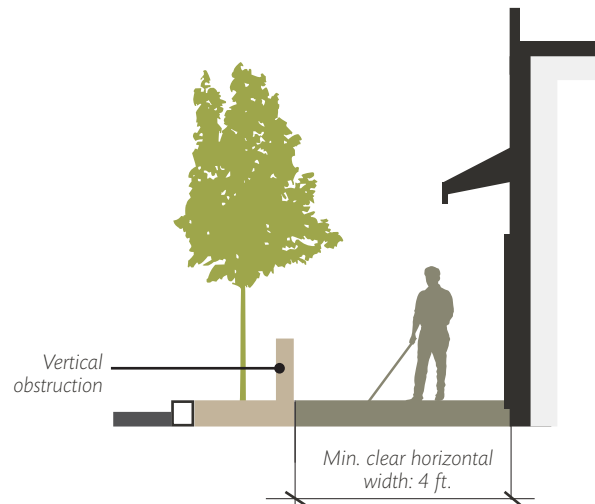

6. If an object must protrude farther than 4 inches into a pedestrian access route at a height greater than 27 inches and less than 80 inches above the sidewalk surface, it must include a warning device that is detectable by a vision-impaired person who navigates with a cane. The minimum 4 foot pedestrian access route must still be provided around the object. (See [City Standard Specifications](#) for warning devices.)

7-4(E)(1)(vi) Landscape/Buffer Zone Requirements

1. Landscape/buffer zones are required for all new development.
2. Landscape/buffer zones must meet the minimum widths in [TABLE 7.2.29](#).
3. Landscape/buffer zone surfacing may consist of planting areas or a walkable surface provided that it is visually distinct from the pedestrian access route.
4. It is strongly encouraged to include landscape/buffer zones in road reconstruction projects, especially along higher speed roadways, to improve pedestrian safety and comfort. Due to constrained right-of-way, buffers shall be provided as space permits. Where 2-foot width or less is available for the landscape/buffer zone, the sidewalk may be widened instead of providing the buffer.
5. Landscape/buffer zones are a high priority along corridors where transit operates.
6. In locations where there is insufficient right-of-way for landscape/buffer zone, street trees shall be located in accordance with [Part 6-6-2 Street Tree Ordinance \(ROA 1994\)](#). Where street trees are provided, the minimum pedestrian access route must be maintained by the adjacent property owner(s) at all times.
7. For minimum planting area size, plant size, spacing, soil condition, installation, irrigation, and other general information applicable to planting in the City right-of-way, see [IDO Subsection 14-16-5-6\(C\), General Landscaping Standards](#).
8. For information about required street trees, their location, and tree well dimensions, see [IDO Section 14-16-5-6\(D\) Street Frontage and Frontage Landscaping](#) and [Part 6-6-2 Street Tree Ordinance \(ROA 1994\)](#).

9. Landscape/buffer zones shall be designed and used per low-impact development (LID) guidelines.

7-4(E)(1)(vii) Curb Ramp Requirements

1. All curb ramps shall meet or exceed ADA/PROWAG requirements.
2. Curb ramps are required to provide access between elevated pedestrian facilities and road surfaces at pedestrian crossings. Ramps shall be installed at all intersections unless pedestrian crossing is prohibited. For the purposes of this section, the following definitions apply:
 - a. **Intersection:** The location where two roadways (public or private) intersect.
 - b. **Intersection crosswalk:** The extension of a sidewalk or shoulder across an intersection, whether it is marked or not.
3. Curb ramps are categorized by their design and position relative to the pedestrian facility and roadway. [FIGURE 7.4.67](#), [FIGURE 7.4.68](#), and [FIGURE 7.4.69](#) provide guidelines and illustrate examples of common ramps that can be used in different situations.
 - a. Perpendicular curb ramps shall have a running slope that cuts through or is built up to the gutter grade break at right angles.

FIGURE 7.4.67 Perpendicular Curb Ramp

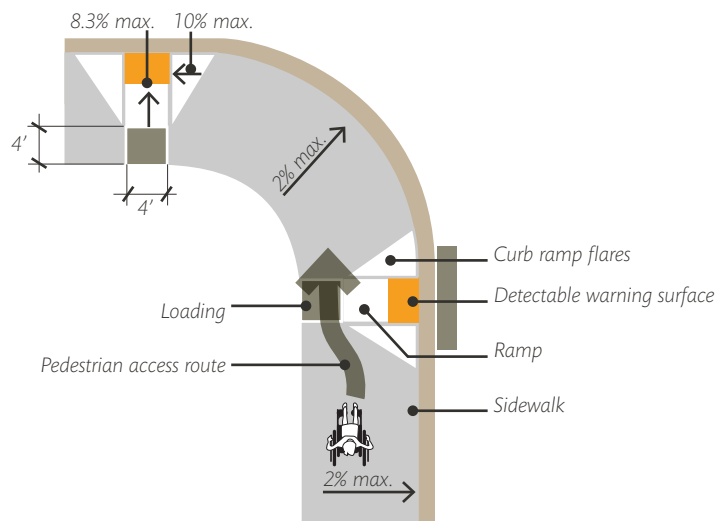

- b. Parallel curb ramps shall have a ramp running slopes that are in-line with the direction of sidewalk travel.

FIGURE 7.4.68 Parallel Curb Ramp

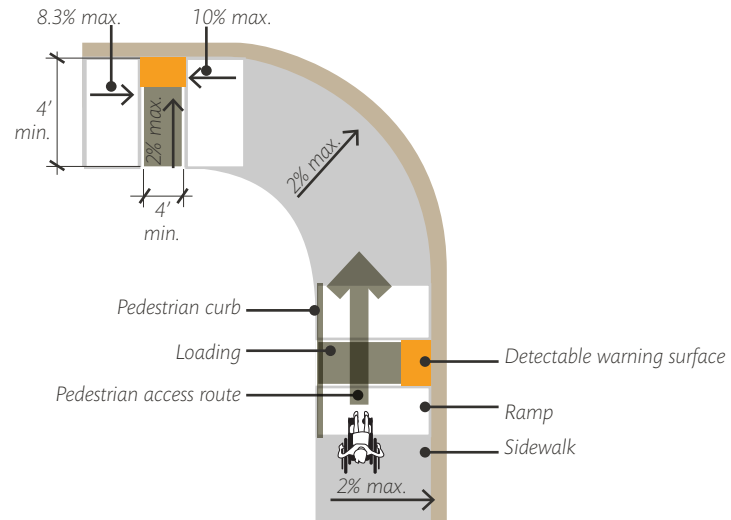

c. *Directional curb ramps* shall have a running slope that is in-line with the direction of sidewalk travel.

FIGURE 7.4.69 Directional Curb Ramp

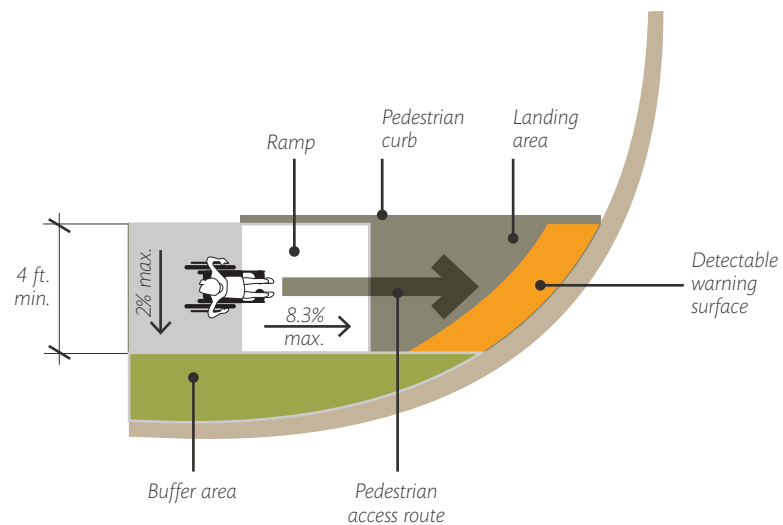

4. Curb ramps shall be aligned to fall within the boundaries of crosswalks, marked or unmarked, so that pedestrians who have vision or mobility impairments are not directed outside the crosswalk or into a vehicle travel lane.
5. As much as possible, curb ramps shall be aligned in-line with the direction of pedestrian travel. ADA/PROWAG compliant ramps shall be wholly within the City right-of-way.
6. During reconstruction projects on collector and arterial roadways, parallel or perpendicular curb ramps shall replace diagonal ramps, where feasible.

- Ramps on the opposing side of the street shall be reconstructed to match newly installed parallel or perpendicular curb ramps.
7. Diagonal curb ramps and blended transition ramps are generally discouraged in new construction projects. They may be acceptable at the intersections of major local and normal local roadways. See [Part 7-4\(J\) Local Streets](#) for more information. All diagonal and blended transition ramps shall be ADA/PROWAG compliant.
 8. Ramps for crossings at intersections shall be located as close to the intersection as practicable to make pedestrians more visible to turning vehicles.
 9. The running slope of the curb ramp shall not exceed 8.3%. To ensure ADA/PROWAG compliance, it is recommended that the running slope be designed at a maximum of 7.5%. The City Engineer may allow exceptions to these requirements for road reconstruction projects if compliance is not feasible.
 10. For connections to steep roadways the ramp does not need to exceed 15 feet in length. Refer to [PROWAG](#) for additional guidance.
 11. The change in grade at the bottom of the curb ramp and adjoining road surface is typically 10% and shall not exceed 13.3%. The counter slope of the gutter or road at the-foot of a curb ramp is not to exceed 5.0%. See [FIGURE 7.4.70](#) for the maximum allowed counter slope.

FIGURE 7.4.70 Curb Ramp Counter Slope

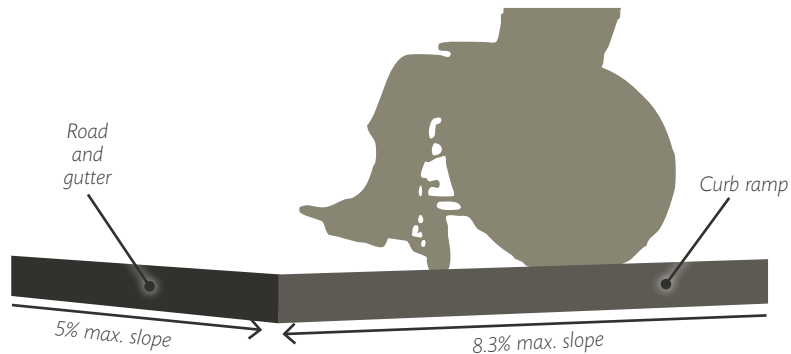

12. The maximum cross slope of a curb ramp is 2%. To ensure ADA/PROWAG compliance, it is recommended that cross slopes be designed at 1.5%.
13. Ramps shall be as wide as the adjoining sidewalk to the greatest extent feasible. The minimum width of the ramp, excluding side flares, is 4 feet.
14. For parallel ramps, a level landing shall be provided at the bottom the ramp within the pedestrian access route. The landing length and width shall be at least 4 feet. The running and cross slopes of the landing shall not exceed 2%. To ensure ADA/PROWAG compliance, it is recommended that running and cross slope be designed at 1.5%.
15. For perpendicular ramps, a level landing shall be provided at the top the ramp within the pedestrian access route. The landing length and width shall be at least 4 feet. The running and cross slopes of the landing shall not exceed 2%. To ensure ADA/PROWAG compliance, it is recommended that running and cross slope be designed at 1.5%.
16. The running and cross slopes for mid-block crossings may match the grade of the roadway.

17. Beyond the bottom grade break where the ramp meets the roadway, a clear space of 4 feet by 4 feet shall be provided within the width of the pedestrian street crossing (marked or unmarked crosswalk) and wholly outside of the parallel vehicle travel lane.

FIGURE 7.4.71 Curb Ramp Clear Space

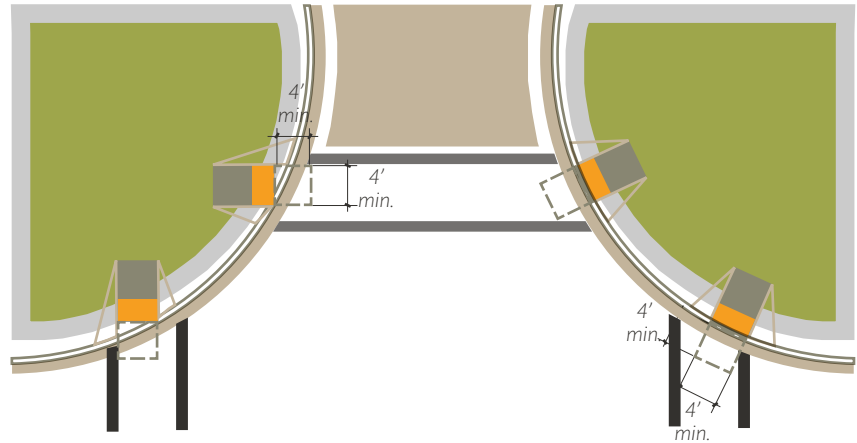

18. The maximum slope of the side flares between the curb ramp and the sidewalk is 10% as measured parallel to the gutter.
19. Ramps shall not be obstructed by hydrants, signposts, poles, utilities, or other vertical obstructions. Manhole, water meters, or valve covers may need to be adjusted to match the ramp slope.
20. Surface materials used for curb ramps shall be firm, stable and slip-resistant.
21. Curb ramps shall include a detectable warning surface (DWS), measuring 2 feet in the direction of travel and the full width of the ramp, excluding the flares. The DWS shall be placed at the back of the curb, but is not required to follow a curb radius.
22. DWS are required on all curb ramps located in City right-of-way. They are required at driveway entrances that are wider than 24'.
23. Detectable warning surfaces shall contrast visually with the adjacent gutter, road or walkway surface, either light-on-dark or dark-on-light.

7-4(E)(1)(viii) Pedestrian Signal Devices

1. In accordance with PROWAG, all new or reconstructed pedestrian signal devices shall be installed to be accessible to pedestrians with vision or mobility impairments. Signal poles shall be located to not obstruct pedestrian movements.
2. Criteria for accessible pedestrian signals are provided in [Accessible Sidewalks and Street Crossings](#) by the U.S. Department of Transportation, Federal Highway Administration.

7-4(E)(1)(ix) Crosswalk Design

1. Crosswalks indicate to pedestrians where to safely cross a street. For more guidance on appropriate locations for crosswalks, see [Section 7-4\(A\)\(7\)](#).

2. See [Part 7-4\(C\) Pavement Design](#) for guidance on appropriate materials to be used in the crosswalk.
3. The running slope and cross slope shall meet ADA/PROWAG requirements.
4. In Centers, marked crosswalks should be at least 10 feet wide and should match the width of the sidewalk. In other areas, marked crosswalks should be no less than 6 feet wide.
5. Marked crosswalk lines should extend the full length of the crossing.
6. Curb extensions may be provided at crosswalks to reduce the crossing distance for pedestrians, depending on roadway conditions and appropriate curb return radius. See the [NACTO Urban Street Design Guide](#) or other accepted standards for additional guidance on curb extension design and appropriate situations for implementation.
7. See [FIGURE 7.4.72](#) for acceptable crosswalk marking designs. See the [MUTCD](#) and [City Standard Specifications](#) for guidance on pavement markings.

FIGURE 7.4.72 Crosswalk Marking

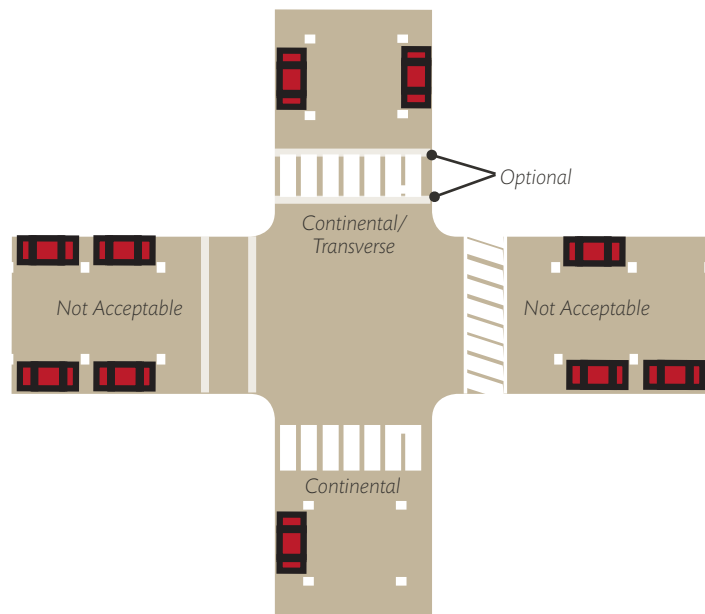

7-4(E)(1)(x) Refuge Islands

1. Median refuges or pedestrian safety islands (referred to as “refuge islands”) are protected spaces in the center of the roads, and may be located at signalized or unsignalized intersections or at mid-block crossings. At unsignalized crossings median refuges enable bicyclists and pedestrians to safely cross a street halfway.
2. These features may be used in combination with other dedicated crossing elements, including marked crosswalks, signage, flash beacons, HAWK signals, and traffic signals. See the Designated Pedestrian Crossings discussion in [Article 7-4 Design Standards](#) for additional information.
3. Refuge islands are recommended for designated pedestrian crossings under the any of the following circumstances, as right-of-way allows:
 - a. Where pedestrians must cross a total of 3 or more lanes.
 - b. Along designated bicycle routes.

- c. Where there are high-volume pedestrian and/or bicycle crossings.
 - d. On roads with speeds above 30 MPH and/or traffic volumes higher than 12,000 Average Daily Traffic (ADT) that provide impediments to safe crossing movements.
4. Refuge islands shall be a minimum of 6 feet wide, with a width of 8 feet to 10 feet preferred. If the minimum 6-foot wide median cannot be provided without conflicting with a pedestrian access route, the Traffic Engineer may approve a median modification eliminate the conflict.
 5. A detectable warning surface is required for all refuge islands.
 6. Refuge islands should provide a clear 6 foot level waiting area within the median. Median refuge islands should have clear signage, pavement markings, curbs, and/or raised elements, such as plantings or bollards, to protect pedestrians waiting in the center of the roadway.
 7. Examples of refuge islands are provided in [FIGURE 7.4.73](#) and [FIGURE 7.4.74](#).
 8. Analysis of vehicle access should be considered as the presence of refuge islands may result in restrictions to vehicle turn movements.
 9. Additional design guidance for refuge islands is provided in the [NACTO Urban Street Design Guide](#), the [NACTO Urban Bikeway Design Guide](#), and other acceptable design guidance documents.

FIGURE 7.4.73 Refuge Island – At Grade

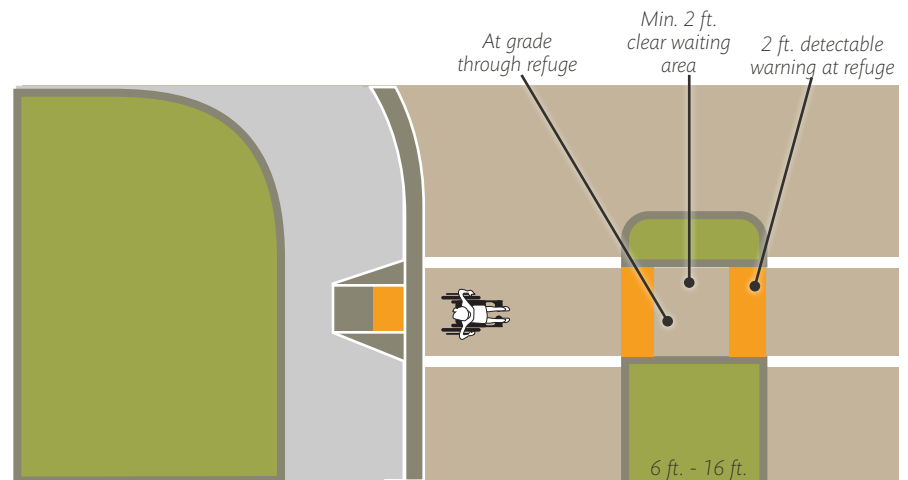
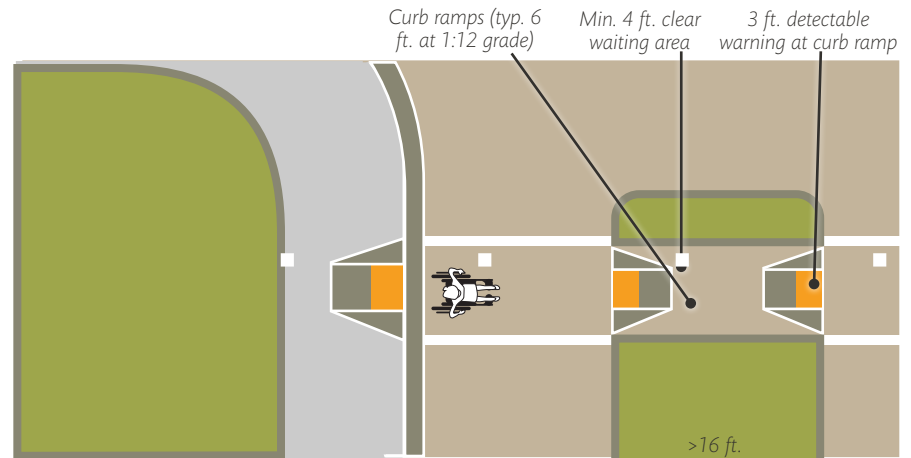

FIGURE 7.4.74 Refuge Island – Raised Median



Section 7-4(E)(2) Pedestrian Walkways

1. All existing and proposed development shall provide safe, direct, and convenient pedestrian access routes (referred to as “pedestrian walkways”) connecting main entrances of buildings, establishments, or uses on a site that allow for public access, with all other such entrances and with available access points. This includes, but is not limited to parking sites, passenger loading zones, streets, sidewalks, and transit stops. On-site walkways shall also be provided to any abutting public park, trail, Major Public Open Space, or other civic or institutional use.
2. Per the [IDO](#), the following uses are exempt from the above requirement:
 - a. Single- or two-family dwellings
 - b. Agricultural use
 - c. Open space
 - d. Cemetery
 - e. Wireless Telecommunication Facility
 - f. Minor utilities
 - g. Other uses not containing a principal building on the premises (with the exception of a parking facility)
3. Pedestrian access on proposed developments shall consist of 6 foot wide accessible, direct, clearly discernible, and ADA/PROWAG-compliant walkway or multi-use path from the City right-of-way to main entrances.
4. Commercial or multi-family developments requiring 5 or fewer parking spaces shall provide a minimum 4 foot walkway.
5. Pedestrian walkways between buildings as required in [IDO Subsection 5-3\(D\)\(3\) On-site Pedestrian Connections](#) shall have a minimum width of 5 feet.
6. Pedestrian walkways located on private property shall be constructed of concrete, asphalt, or other firm, stable, and slip-resistant material, as approved by the City Engineer.
7. Pedestrian walkways that connect to the public rights-of-way shall be physically separated from vehicular surface areas, except where required to cross a drive aisle; such crossings shall be perpendicular wherever practicable.
8. Private walkways shall be required in areas served by any street. Private walkways shall provide general pedestrian access within the development

- served and shall connect with all public sidewalks, public streets, parks, and open space. Each block, or each building in the case of multi-family dwellings, shall be served by a connection to the pedestrian access system.
9. Private ways that connects to the public roadway system and that are designed for travel speeds of 10 MPH or below may allow for pedestrians, bicyclists, and /or vehicles to share the same right-of-way, rather than providing discrete space for each user, as approved by the City Engineer.

Part 7-4(F) Bikeways and Trails

Section 7-4(F)(1) General Provisions

1. Guidance for the development of bikeways is rapidly evolving with new designs being explored, tested, and incorporated into national guidance. This section builds upon guidance provided by national design manuals and identifies locally-preferred standards and procedures.
2. For additional detail and guidance, refer to the latest version of the following guides: the [AASHTO Guide for the Development of Bicycle Facilities](#), the [NACTO Urban Bikeway Design Guide](#), the [MUTCD](#), and the [City BTFP](#).
3. NACTO and AASHTO guides shall be used as guidance on pavement markings intended to improve the visibility of bicycle lanes, striping of lanes and buffers, including use of dashed lines to mark driveway access points, traffic merging areas, and transit stops.
4. The [MUTCD](#) shall be used for standards related to bicycle lane symbols, pavement markings, and signage.
5. High bicycle activity areas include facilities approaching and within a Center or Premium Transit station area or near a school. Other high activity areas include neighborhoods with an average residential density of 10 dwelling units per acre or more.

Section 7-4(F)(2) Locations of Future Facilities

1. The location of future bikeways and trails is shown on both the [LRBS](#) and in the [BTFP](#). These future system maps show the facilities necessary to provide an integrated bikeway and trail network. The most recently updated future system map, either in the [LRBS](#) or the [BTFP](#), shall be used to require planned bikeways and trails as part of new development.
2. New bicycle infrastructure should be considered as part of all reconstruction and new roadway projects.
3. In locations not identified on the [LRBS](#) or the [BTFP](#) maps, bikeways and/or trails may be required if they connect or close a gap in the existing system.

Section 7-4(F)(3) Bicycle Lanes

7-4(F)(3)(i) Definitions and General Provisions

1. A bicycle lane is a lane on the roadway that has been designated by striping and pavement markings for preferential or exclusive use by bicyclists.
2. Bicycle buffers are the physical space that separates bicycle lanes from vehicle lanes. Buffers may consist of pavement markings or some form of vertical separation. See [Subsection 7-4\(F\)\(3\)\(iii\)](#) for additional guidance

- on separated bicycle lanes with vertical barriers. See the [NACTO Urban Bikeway Design Guide](#) for guidance on bicycle buffer design options.
3. Bicycle buffers are recommended on streets with higher speeds and traffic volumes, and/or as right-of-way allows.
 4. Bicycle lanes are not required on local streets with speeds of 25 MPH or less, low traffic volumes, narrow right-of-way, or that provide access to single-family residences; on these streets, bicyclists should share lanes with vehicle travel. Common treatments to facilitate shared lanes include signage, pavement markings, and bicycle route and bicycle boulevard designations.
 5. Bicycle lanes should be provided on all new collector roadways and evaluated on all new arterial roadways.
 6. The addition of bicycle lanes as part of restriping, resurfacing, and rehabilitation projects on existing arterial and collector roadways must be evaluated, after reviewing network connectivity, and in accordance with the [Complete Streets Ordinance \(Part 6-5-6 ROA 1994\)](#).
 7. Consult [ABC Comp Plan](#) Table 7-5: Priority Street Element Matrix for recommendations on bicycle lanes and bicycle buffers on Corridors.
 8. Bicycle lanes may be implemented on existing roadways by reducing automobile travel lane and median widths, reducing the number of travel lanes, and/or reconsidering the need for parking. If reconstructed bicycle lanes cannot meet the requirements of this section, the bicycle lanes should be installed to meet minimum national guidance recommendations.

FIGURE 7.4.75 Bicycle Lane

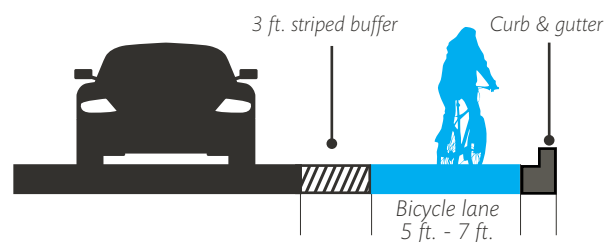

7-4(F)(3)(ii) Design Considerations

1. Bicycle lane and buffer widths are provided in [TABLE 7.2.29](#). Wider bicycle lanes and/or striped buffers are desirable on higher speed roadways (i.e. 35 MPH or greater). Following the [ABC Comp Plan](#) Table 7-5: Priority Street Element Matrix, wider widths for bicycle lanes and bicycle buffers should be included on Corridors where bicycle lanes are a priority.
2. Bike lanes narrower than those shown in [TABLE 7.2.29](#) may be considered where bicycle lanes are desirable but available right-of-way is insufficient. In constrained right-of-way situations, the widths of bicycle lanes, general purpose travel lanes, and medians shall meet minimum national guidance recommendations.
3. The width of bicycle lanes is measured from the centerline of the painted edgeline to the edge of asphalt pavement. Lane width does not include the gutter pan.

4. Bicycle lanes shall be constructed or reconstructed level and flush with roadside gutter pans with no more than 5/8-inch vertical difference.
5. Bicycle lanes shall be constructed to avoid hazardous conditions that might force awkward or unsafe bicycle movements. Storm drainage and other utilities shall be designed and located to minimize impact.
6. Improvements to intersections with bicycle lanes, shall include bicycle-sensitive signal actuation where feasible. See [NACTO Urban Bikeway Design Guide](#) for marking detection area and detection operations.
7. The dropping of bicycle lanes at intersections is strongly discouraged. Where feasible, roadway designs shall incorporate bicycle treatments at intersections to reduce conflicts between cyclists and motorists. Options include bicycle boxes, intersection crossing markings, median refuge islands, dashed lines at the entrance to right turn lanes, and the use of sharrows for shared bicycle lane and right turn only lanes. See [NACTO Urban Bikeway Design Guide](#), or other approved design manual, for additional guidance.
8. Where on-street parallel parking is present and bicycle lanes are located to the left of automobile parking, a minimum combined width of 13 feet is required, with a recommended 7 foot wide parallel parking stall and a 6 foot wide bicycle lane. The gutter pan may be included in the parking stall width.
9. Vertical delineators at intersections should be considered in situations where the bicycle lane is used as a turning bay for vehicles.

7-4(F)(3)(iii) Separated Bicycle Lane Design

1. Separated bicycle lanes, also called protected bicycle lanes or cycle tracks, include some form of vertical element to separate the bicycle lane from automobile travel lanes. The vertical element may include tubular markers, moveable planters, raised curb, or vehicle parking.
2. Separated bicycle lanes may be located at the street level, raised to an intermediate level between the roadway and the sidewalk, or at the same level as the sidewalks.
3. Separated bicycle lanes at the sidewalk level should have some form of buffer or visual means of differentiating between the bicycle lane and the sidewalk. See the [NACTO Urban Bikeway Design Guide](#) for additional information on raised bicycle lanes at intermediate levels.
4. Separated bicycle lanes are most appropriate along roadways with higher travel speeds and for connections between and within [ABC Comp Plan Centers](#).
5. General recommended separated bicycle lane dimensions involve a 6.5-foot lane and a 3-foot buffer. The ranges provided in [TABLE 7.2.29](#) allow sufficient flexibility for striped buffered bicycle lanes or cycle tracks to be implemented within the recommended dimensions.
6. Two-way cycle tracks are discouraged. See [NACTO Urban Bikeway Design Guide](#) for separated bicycle lane/cycle track design guidance.

Section 7-4(F)(4) Bicycle Routes

1. Bicycle routes are designated roadways in which cyclists share roadway space with motorists. There is no designated infrastructure, though directional and informational signage is recommended.
2. Bicycle routes are recommended on low-volume (i.e. below 3,000 ADT), low-speed roadways (i.e. posted speeds of 25 MPH or below). Bicycle

routes may feature some traffic calming elements, and may be marked with sharrows.

3. Bicycle route designations may be used on existing roadways with constrained rights-of-way and where existing bicycle lanes do not meet the minimum design standards. This option is only appropriate on roads with low average travel speeds and preferably with low traffic volumes.
4. The sign, "Bicycles May Use Full Lane," or alternate as approved by the City Engineer, is the preferred signage to indicate shared-lane facilities. Sharrow lane markings also improve the visibility of cyclists on a shared roadway.
5. See [NACTO Urban Bikeway Design Guide](#) and [AASHTO Guide for the Development of Bicycle Facilities](#) for further guidance on wayfinding and shared lane markings.

Section 7-4(F)(5) Bicycle Boulevards

1. Bicycle boulevards are enhanced bicycle routes designed to encourage the through-movement of bicycles, while maintaining local access for motor vehicle travel.
2. Bicycle boulevards are recommended on low-volume (i.e. below 3,000 ADT), low-speed roadways (i.e. posted speed of 25 MPH or below) with direct access to destinations. Ideally, they should be at least 2 miles long. Bicycle boulevards may be parallel to roadways with bicycle lanes to provide lower-stress alternative routes.
3. Traffic calming devices are used to control motor vehicle speeds and discourage through-vehicle trips. These devices may include diverters, speed humps, traffic circles, or planters that allow through-access by bicycles only. See [Part 7-4\(L\) Traffic Calming](#) for additional guidance.
4. If an existing roadway is designated as a bicycle boulevard, signal timing and stop control should be evaluated to prioritize bicycle movements.
5. Additional guidance on bicycle boulevards is provided in [BTFP](#) Section 7(C) (6).

Section 7-4(F)(6) Paved Trails

7-4(F)(6)(i) Definitions and General Provisions

1. Paved trails, also called multi-use trails or shared-use paths, are facilities that are dedicated for pedestrians and cyclists and are designed for use by people of all abilities for transportation and recreational purposes.
2. Trails are physically separated from vehicular traffic and are either within the roadway right-of-way or within an easement.
3. Consult the [BTFP](#) and the [LRBS](#) for future trail locations.

FIGURE 7.4.76 Paved Trail

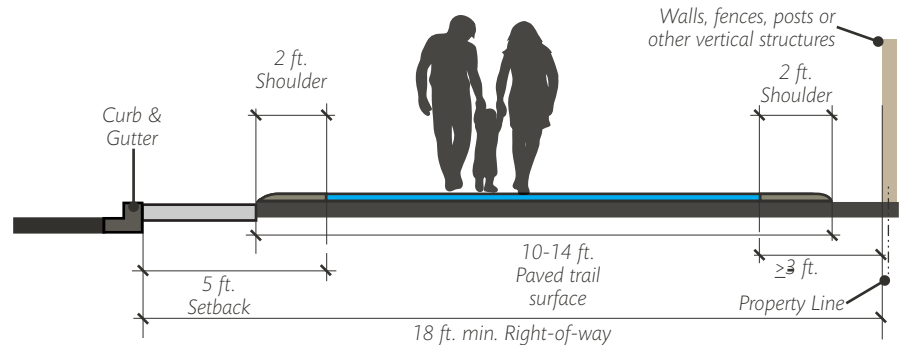

7-4(F)(6)(ii) Design Standards

1. The minimum trail width shall be 10 feet, excluding shoulders. The recommended trail width is 12 feet, or 14 feet for high-use areas and long-distance routes, as defined in the [LRBS](#).
2. Exceptions to the minimum trail width may be approved by the City Engineer. If approved, a Trail Maintenance Agreement is required.
3. The minimum width required for a trail along a roadway is 18 feet, which includes minimum 10 feet for trail, 5 feet for setback from the curb, and 3 feet setback from any adjacent property line. The setbacks from the curb and the property line may include shoulders. (See [FIGURE 7.4.76](#)).
4. Whenever possible, easements for trails shall be configured so that a clear field of view for the trail user is provided from each end of the trail.
5. A minimum 2 foot shoulder adjacent to both sides of the trail is required to be constructed of compacted base course, subgrade, or crusher fines, with cross slopes no greater than 2%.
6. A minimum 3 foot buffer is required between the private property line or any vertical structures and the trail, which may include the compacted shoulder.
7. Trail cross slope shall not exceed 2%, unless approved by the City Engineer. To ensure ADA/PROWAG compliance, it is recommended that cross-slopes be designed for a maximum of 1.5% to allow for tolerance in construction. Trail design should carefully consider compound slopes when there is both a cross slope and running slope. See [Part 7-4\(E\) Pedestrian Facilities](#) for slope definitions and requirements.
8. Trails next to steep slopes shall follow the [AASHTO Guide for the Development of Bicycle Facilities](#) for protection requirements.
9. Permeable pavement may be used to address drainage and storm water run-off issues with approval by the City Engineer. Different pavement materials or colors may also be used to fit in with the natural context in locations near major public open spaces.

7-4(F)(6)(iii) Trail Running Slope

1. To the greatest extent feasible the trail running slope shall have a maximum grade of 5%. In constrained conditions, the trail may match but not exceed the general grade established by the adjacent roadway or right-of-way easement.

2. Landings and rest areas shall be provided on extended grades to allow users to stop and rest, particularly for steep trails and high-use trails. The landings should be located outside the trail through lanes. See PROWAG for guidance on the frequency of landing areas.
3. Advance warning signs shall be used to identify trail locations with slopes that greatly exceed ADA guidelines, due to the slope of the road or other unavoidable topographic constraints.

7-4(F)(6)(iv) Curb Ramps

1. Curb Ramps are required to provide access between elevated trails and road surfaces. See [Subsection 7-4\(E\)\(1\)\(vii\) Curb Ramp Requirements](#) in [Part 7-4\(E\) Pedestrian Facilities](#) for additional guidance.
2. For trails, ramp width should match the trail width, excluding side flares. (See [FIGURE 7.4.77](#).) At no point should the access way or ramp be narrower than 10 feet at intersections where a trail is present. Ramps should be free of vertical obstructions.
3. Access ramps shall have a maximum running slope of 8.3%.
4. A slip ramp may be used to connect an on-street bicycle facility to an off-street bicycle facility.

FIGURE 7.4.77 Blended Transition Ramp with Matching Trail and Ramp Width

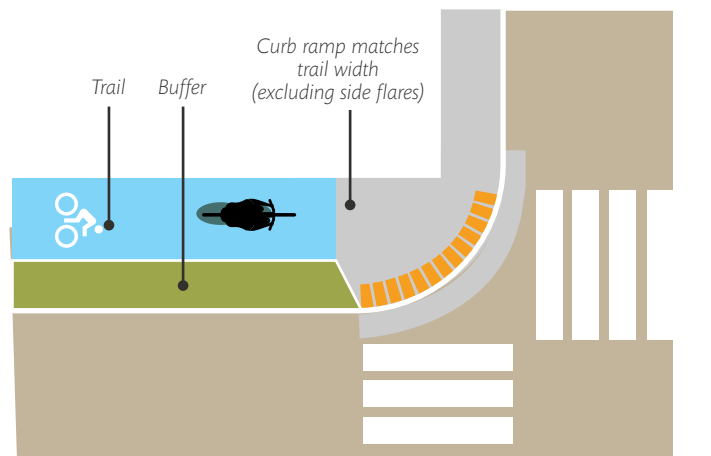

7-4(F)(6)(v) Equestrian Accommodations

Follow the [BTFP](#) recommendations for equestrian accommodations for trail and bridge design where there is known equestrian use and facilities near Open Space.

Section 7-4(F)(7) Trail Alternatives

Where future trails and bicycle lanes are shown in combination on the [BTFP](#) or [LRBS](#), either of 2 alternative designs may be pursued, with approval of the City Engineer.

1. A sidewalk combined with one-way separated bicycle lanes. Sidewalk design for this alternative shall follow requirements specified in [Part 7-4\(E\) Pedestrian Facilities](#). The one-way separated bikeway shall follow the [NACTO Urban Bikeway Design Guide](#), in conjunction with other national guidance.

FIGURE 7.4.78 Trail Alternative 1, Vertical Separation

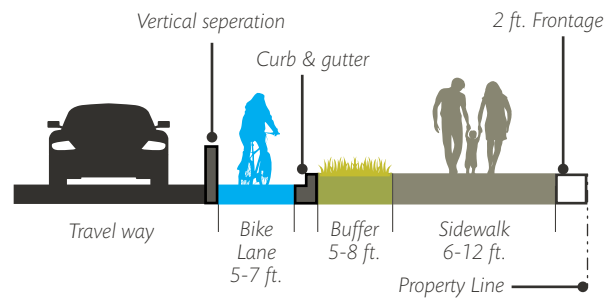

2. A trail may be constructed in lieu of a sidewalk on one side of the street, with a sidewalk on the opposite side of the street. (See [FIGURE 7.4.79](#)). The trail must meet recommended trail width dimensions (10-14 feet) and recommended landscape buffer from [TABLE 7.2.29](#).

FIGURE 7.4.79 Trail Alternative 2, Trail in Lieu of Sidewalk

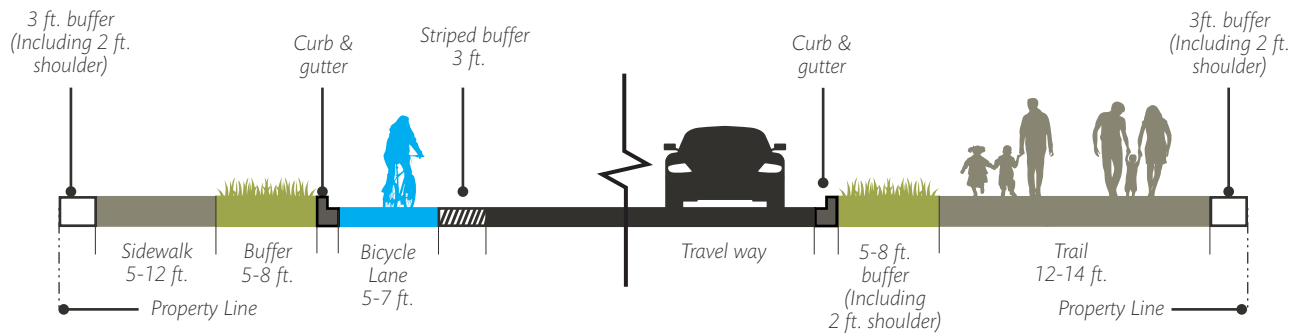

Part 7-4(G) Public Transit

Section 7-4(G)(1) General Provisions

1. The provisions of this section describe appropriate transit stop facilities by location and the layout of stop area features. Other considerations in this section include roadway design issues that should be addressed during reconstruction projects, as well as guidance for dedicated transit infrastructure.
2. Site development applications and City roadway projects may be reviewed by ABQ RIDE and/or Rio Metro Regional Transit District (Rio Metro) for the provision of transit stop amenities, where applicable. Contributions to transit stop amenities may be asked of a site developer as a mitigation measure. See the [Part 7-5\(B\) Traffic Scoping Form and Traffic Impact Study](#) and [Article 7-5 Traffic Studies](#) on mitigation measures for additional guidance.
3. Guidance for this section is derived from the sources listed below. Updated versions of these documents or equivalent sources may be used with the approval of the City Engineer and the affected transit provider.
 - a. U.S. Access Board, [PROWAG](#), 2013.
 - b. NACTO, [Transit Street Design Guide](#), 2016.
 - c. AASHTO, [Guide for the Geometric Design of Transit Facilities on Highways and Streets](#), 2014.
 - d. APTA, [Designing Bus Rapid Transit Running Ways](#), 2010.
 - e. TCRP, Report 90, [Bus Rapid Transit](#), Volume 2: Implementation Guidelines, 2003.

Section 7-4(G)(2) Pedestrian Connections

1. Per [IDO Section 14-16-5-3\(D\)\(3\)\(b\)](#), all non-residential, mixed use, and multi-family developments adjacent to transit stops, stations, and park and ride facilities must provide pedestrian connections to those facilities.
2. Per the [ABC Comp Plan](#) Table 7-5: Priority Street Element Matrix, sidewalks along Premium Transit and Major Transit Corridors are recommended to be wider than the minimum standards in [TABLE 7.2.29](#).
3. Additional guidance on pedestrian crossings is provided in [Part 7-4\(E\) Pedestrian Facilities](#).

Section 7-4(G)(3) Boarding and Alighting Areas

1. At least 1 boarding area shall be provided at each stop or station. At high-volume stops, a similar area should be provided for the rear door(s) as well.
2. The boarding and alighting area shall be a clear space that is at least 5 feet wide in the direction parallel to the roadway and 8 feet wide in the direction perpendicular to the roadway. (See [FIGURE 7.4.80](#)).
3. The slope of the boarding and alighting area shall match the roadway grade in the direction parallel to the roadway. The grade perpendicular to the roadway shall be no more than 2%. (See [FIGURE 7.4.80](#)).

FIGURE 7.4.80 Transit Boarding and Alighting

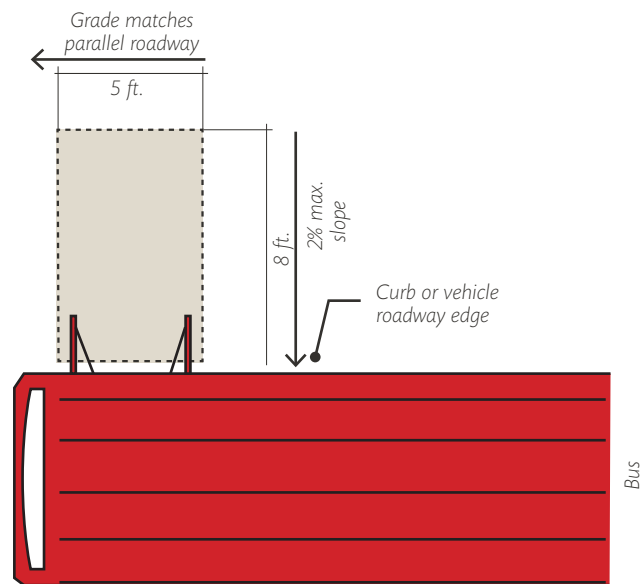

4. The boarding and alighting area shall be firm, stable, and slip-resistant.
5. The boarding and alighting area shall be connected to sidewalks, private pedestrian walkways, existing bus shelters, and roads by an ADA/PROWAG-compliant pedestrian access route. (See [FIGURE 7.4.81](#).)

FIGURE 7.4.81 ADA/PROWAG-compliant Pedestrian Access Route

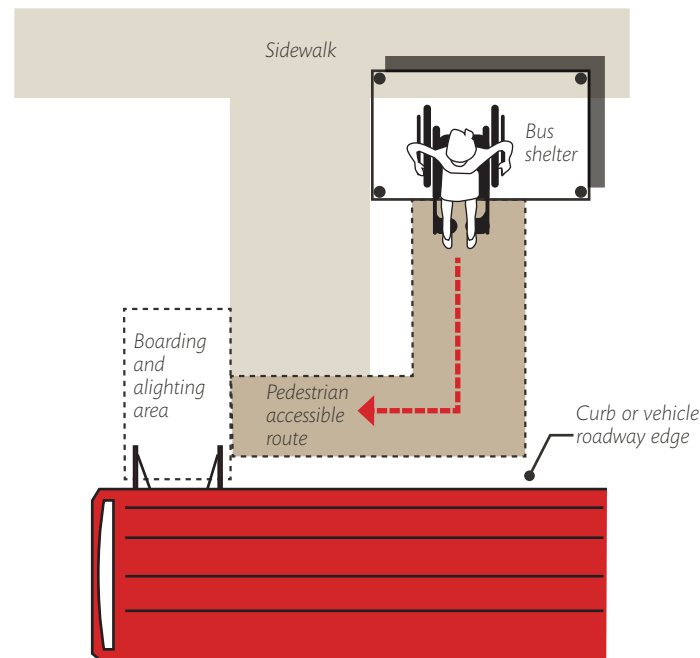

6. All curbside bus stops shall be designed to accommodate at least one bus serving the boarding and alighting area. The length of the bus queuing space depends on the type of vehicle(s) expected to serve the route. If there are multiple routes and thus multiple buses serving the stop, the queuing space should be extended accordingly. Potential transit service expansion and future routes should also be considered.

Section 7-4(G)(4) Transit Stop and Station Types

This section provides guidance on transit stop types and desired amenities by location. It is expected that transit stops will be integrated into the pedestrian realm. Additional right-of-way or easements may be required to implement desired amenities along existing roadways.

Additional guidance on sidewalk widths is provided in [Part 7-4\(E\) Pedestrian Facilities](#). Per [IDO Section 14-16-5-3 \(Access and Connectivity\)](#), pedestrian connections from adjacent developments to transit stops and stations shall be provided.

7-4(G)(4)(i) Basic Transit Stop

1. A basic transit stop consists of an accessible boarding and alighting area with easily identifiable signage indicating the location of the stop. Basic transit stops are most commonly associated with bus transit.
2. Basic stops are the minimum required transit stop infrastructure and are generally acceptable at locations where there no more than 2 buses arrive at the stop per hour in the weekday peak hour. Basic transit stops do not feature benches or shelters.
3. Transit stops should be located near marked or protected pedestrian crossings, where possible.

- a. At near-side stops, at least 10 feet should be provided between the front of the transit vehicle and the edge of the crosswalk.
- b. At far-side stops, least 10 feet should be provided between the back of the vehicle and the edge of the crosswalk; 35 to 50 feet is preferable.

7-4(G)(4)(ii) Transit Stop with Bench

1. A bench should be provided at transit stops on Major Transit Corridors, locations where at least 2 buses arrive at the stop per hour in the peak period, or where considered appropriate by ABQ RIDE and/or Rio Metro.
2. The bench must be located so that it does not block the clear sidewalk width, preferably with the sidewalk between the bench and the curb.
3. The front of the bench should not be placed closer than 4 feet from the back of the curb, or 6 feet from the back of the curb when a travel lane exists immediately adjacent to the curb.
4. Benches should be oriented toward the street or the direction of the approaching transit vehicle.
5. The bench site area should include pedestrian access route connections (minimum 4 feet wide) to the sidewalk and the boarding and alighting area.
6. The bench site should include a level 30 inch by 48 inch maneuvering space adjacent to the bench that is firm, stable, and slip-resistant.
7. ADA/PROWAG-compliant bench design requirements are shown in [FIGURE 7.4.82](#) and listed below:
 - a. Seat length: 42 inches minimum.
 - b. Seat height: 17-19 inches.
 - c. Seat depth: 20-24 inches.
 - d. Seat back, top: 18 inches minimum above the seat.
 - e. Seat back bottom: 2 inches maximum above the seat.
 - f. Separation between the seating surface and the seat back: 2.5 inches minimum.
 - g. The wall of a shelter may serve as the seat back.

FIGURE 7.4.82 ADA/PROWAG-compliant Bench Design Requirements

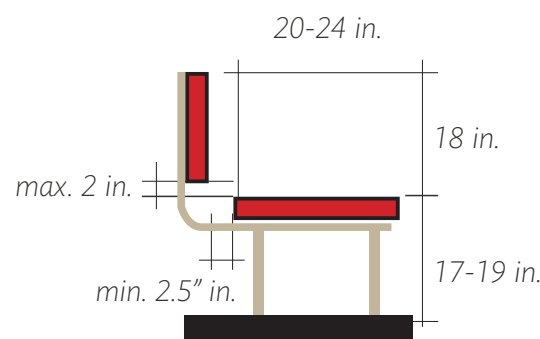

7-4(G)(4)(iii) Transit Stop with Shelter

1. A shelter should be provided, where feasible, at any of the following transit stop locations:
 - a. Along Major Transit Corridors.

- b. *Within Centers.*
 - c. *At locations where at least 3 buses arrive at the stop per hour in the peak period.*
 - d. *Where considered appropriate by ABQ RIDE and/or the Rio Metro RTD.*
2. The shelter must be located so that it does not block the clear sidewalk width.
 3. Shelters should not be placed closer than 4 feet from the leading edge of the roof of the shelter to the face of the curb. Where feasible, 6 feet is desired.
 4. Shelters shall be oriented toward the street or the direction of the approaching transit vehicle.
 5. The shelter site area shall include ADA-compliant pedestrian access route connections (minimum 4 feet wide) to the sidewalk and to the boarding and alighting area.
 6. Shelters should include space to rest, such as a bench or leaning rail.
 7. Shelters shall have a minimum clear floor space of 4 feet by 4 feet for wheelchair users. The clear space shall be located under the shelter roof adjacent to any seating areas and not in front of or behind the seating area.
 8. Any protruding objects in the shelter shall comply with ADA requirements.
 9. The shelter must be located so that it does not block any clear sight distance requirements in [Section 7-4\(I\)\(5\) Sight Distance](#).

7-4(G)(4)(iv) Transit Station

1. Usually associated with a premium service such as Bus Rapid Transit, transit stations are distinguished from transit stops by having level-boarding platforms and passenger amenities, such as ticket vending machines and real-time transit information, as well as common transit stop amenities, such as seating, shelters, and/or leaning rails.
2. Transit stations are recommended along Premium Transit Corridors.
3. Transit stations may be located curbside or in the median. If a station is located in the median, marked or protected pedestrian crossings must be provided to the sidewalks on either side of the street.
4. Pedestrian crossings shall be provided directly to or within 100 feet of the transit station. See [Article 7-4 Design Standards](#) for additional guidance on pedestrian crossings.
5. Additional guidance on transit station design can be found in the [NACTO Transit Street Design Guide](#) or other documents considered appropriate by ABQ RIDE and/or Rio Metro.

7-4(G)(4)(v) Park and Ride Facilities

1. Parking lots or formal station facilities that allow commuters and other transit users to leave their vehicles and transfer to public transit vehicles. Park and ride facilities generally serve as transfer facilities for multiple routes. Park and rides should include space for picking up and dropping off passengers, bicycle racks, traveler information, shelters, and other station amenities.
2. Design for park and ride facilities is based on the available parcel or lot size and should follow general site development standards outlined in the DPM, including on-site circulation requirements and guidelines for pedestrian access from surrounding roads to boarding and alighting areas.
3. Pedestrian access should be provided from developments at sites adjacent to park and ride facilities.

4. Guidance on vehicle access to park and ride facilities is provided in [Part 7-4\(B\) Site Access Points](#).

Section 7-4(G)(5) Roadway Design Considerations for Transit in Mixed Flow Traffic

7-4(G)(5)(i) Travel Lanes

1. Where transit operates in mixed flow traffic – generally the outside lane – widths at the higher end of the ranges provided in [TABLE 7.2.29](#) in [Part 7-2\(D\) Street Elements](#) may be appropriate. Narrow lanes (i.e. at the low end of the range provided in [TABLE 7.2.29](#) in [Part 7-2\(D\) Street Elements](#)) may be provided for other lanes along the same corridor where transit does not operate).
2. Where transit operates adjacent to on-street parking, 12-foot travel lanes and 8-foot wide on-street parking spaces are preferred, though narrower widths may be considered under constrained circumstances. (See [FIGURE 7.4.83](#).)
3. The buffer/landscape zone also serves to separate transit vehicles from pedestrians, utilities, and other elements in the Pedestrian Realm. See [Part 7-4\(E\) Pedestrian Facilities](#) for additional guidance on sidewalk dimensions and buffers along the corridors where transit operates.

FIGURE 7.4.83 Travel Lane

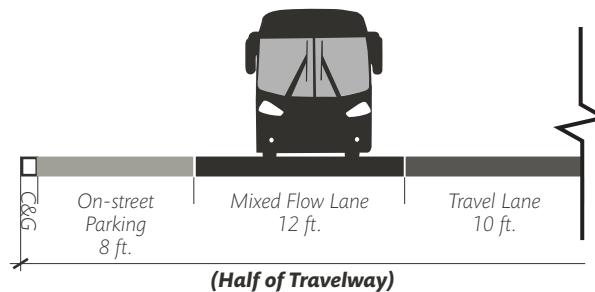

7-4(G)(5)(ii) Bus Turnouts and Bus Bays

1. Additional right-of-way may be required for bus turnouts and bus bays on arterial and collector streets at locations determined by the City Engineer. The width of the additional right-of-way will be whatever is necessary to provide 10 feet from face of the curb along the bus bay, plus the additional area for a shelter. The length of the bus bay depends on the length of the vehicle(s) serving the route(s).
2. Dedication of right-of-way for transit amenities (e.g. bus bay, shelter, and sidewalk) may be required as a condition of approval for site plans. An easement for these purposes is satisfactory provided platting is not otherwise occurring on the property. Bus bay design must provide for conveyance of nuisance drainage flow by valley gutter or other approved means.
3. Bus turnouts consist of a dedicated zone on the side of a roadway for passenger boarding and alighting that prevents travel lanes from being

blocked when buses stop to pick up and drop off passengers. (See [FIGURE 7.4.84](#)).

4. Bus turnouts may be used where sufficient space exists on the side of the road to allow a transit vehicle to fully exit the travel lane. Bus turnouts require zones for deceleration, stopping, and accelerating to ensure transit vehicles can safely enter and exit the turnout, and may require the restriction of on-street parking to provide acceleration and deceleration zones.
5. Bus bays are similar to bus turnouts in that they provide a dedicated space for passenger boarding and alighting at the side of a road. In contrast to turnouts, bus bays have a protected zone with entrance and exit tapers. Bus bays require setbacks to enable the transit vehicle to completely exit the travel lane. (See [FIGURE 7.4.85](#)).
6. Bus bays are most appropriate along corridors where the speed limit is 40 MPH or greater, or locations where maintaining efficient vehicle throughput is a high priority. Bus bays may be suitable in other situations.
7. Required locations for bus bays shall be determined by the City Engineer and ABQ RIDE and/or Rio Metro.
8. Bus bay dimensional requirements are provided in the [City Standard Specifications](#).

FIGURE 7.4.84 Bus Turnout

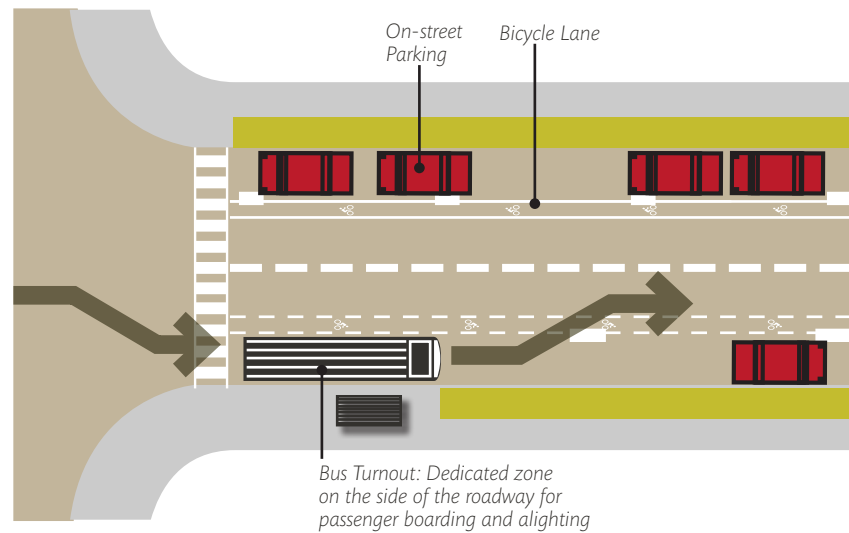
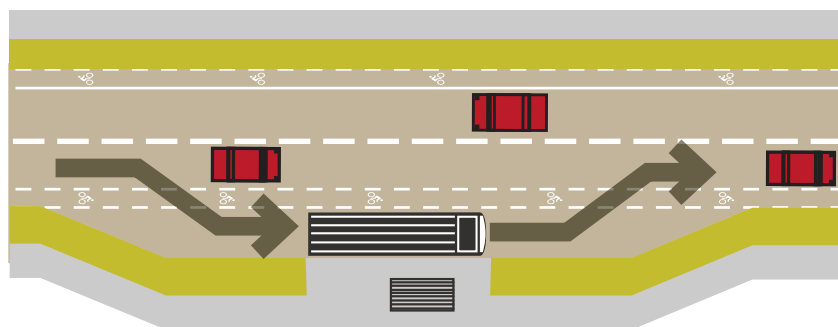

FIGURE 7.4.85 Bus Bay



7-4(G)(5)(iii) Pavement Design

1. A more durable pavement design (e.g. concrete) may be desirable for transit lanes, loading areas, station areas, and stops along Premium Transit and Major Transit Corridors with high-frequency bus service (i.e. at least 4 buses per hour).
2. Specific pavement design and thickness should be considered based on factors such as expected vehicle traffic and subgrade conditions.
3. Typical gross bus weights including vehicle and passengers are 40,000 lbs. for standard buses and 60,000 lbs. for articulated buses.

7-4(G)(5)(iv) Transit Conflicts with Bicycles

1. Parallel networks in which bicycle facilities are provided on a nearby street are an appropriate means of minimizing conflicts.
2. Where transit service operates in mixed-flow traffic and coincides with on-street bicycle lanes, signage and pavement markings should be provided to improve awareness for cyclists and bus drivers. Preferred treatments include dashed lines along bicycle lanes at the entrance to the bus stop area.
3. Rerouting of bicycle lanes and boarding islands that direct bicyclists behind a transit stop may be employed in areas with sufficient right-of-way and high levels of conflict. Additional guidance on boarding islands and other treatments to alleviate conflicts between bicyclists and transit vehicles can be found in the [NACTO Transit Street Design Guide](#).

Section 7-4(G)(6) Dedicated Transit Infrastructure

1. Dedicated transit infrastructure refers to the portion of the road or right-of-way allocated exclusively for transit vehicles and associated improvements. This design approach reduces traffic delays and conflicts and improves transit travel time reliability.
2. Dedicated transit infrastructure may take the form of a separate lane or transit guideway and may be located curbside or in the median.
3. Dedicated transit lanes may be shared use under limited contexts, such as for emergency response, providing business access along a curbside lane, or through time-of-day restrictions.
4. Signage and pavement markings are necessary where physical separations between dedicated transit infrastructure and general purpose travel lanes do not exist.

5. Dedicated transit infrastructure is recommended along Premium Transit and Major Transit Corridors.
6. Additional guidance on dedicated transit infrastructure can be found in the [NACTO Transit Street Design Guide](#) or other documents considered appropriate by ABQ RIDE and/or Rio Metro.
7. Additional guidance on lane striping and pavement markings required for dedicated transit infrastructure can be found in the [MUTCD](#).

7-4(G)(6)(i) Curbside Transit Lanes

1. Dedicated curbside bus transit lanes should be 10-12 feet wide, not including the gutter pan, with a recommended width of 11 feet. Narrower lanes are most appropriate when operating speeds are 25 MPH or below, or where right-of-way is severely constricted.
2. Lane widths at stop locations may be reduced to 10 feet.
3. Curbside lanes may be separated by concrete barrier or rumble strip, depending on the roadway design speed and available right-of-way.
4. If right-of-way is constrained and no landscape buffer currently exists, a minimum 2-4 feet, including the gutter, should be provided to separate the sidewalk and the curbside transit lane.
5. Curbside transit lanes may be used for business access or right turns. Alternatively, right turns may be restricted to signalized turning movements.

7-4(G)(6)(ii) Median Transit Lanes

1. Median transit lanes should be 11-13 feet wide, with a recommended width of 12 feet. The lane width may be reduced if there are guideways or tracks to steer transit travel.
2. Median transit lanes and center platform stations require a minimum of 28 feet for the boarding and alighting area and dedicated lanes on both sides. (See [FIGURE 7.4.86](#)).
3. Some form of separation, such as a raised curb or rumble strips, is recommended between the transit lane and adjacent general purpose lanes.
4. Roadway designs must accommodate left turns at regular intervals through dedicated turn lanes and protected signals.

FIGURE 7.4.86 Median Transit Lanes and Center Platform Station

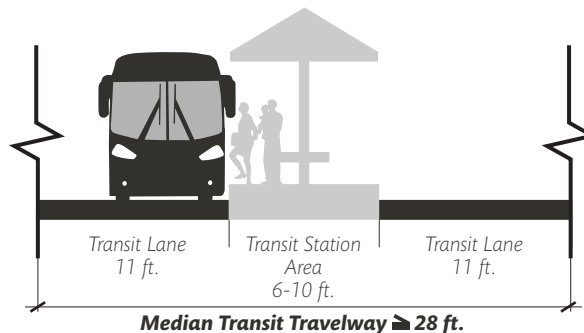

7-4(G)(6)(iii) Queue Jump Facilities

1. Queue jump facilities are short transit-only facilities at intersections that are combined with signal prioritization to allow for buses to enter traffic flow ahead of general purpose travel lanes. Queue jump facilities can be applied in the curbside travel lane where stops are located adjacent to signalized intersections or in a short-length special bus-only travel lane.
2. Queue jump facilities may require additional right-of-way at intersections or the reallocation of a dedicated right-turn lane. Curbside queue jump facilities require right turns to be made from the nearest inside travel lane.
3. Queue jump facilities are most appropriate along Major Transit and Premium Transit Corridors.
4. Additional guidance on the design of queue jump facilities can be found in the [NACTO Transit Street Design Guide](#) or other documents considered appropriate by ABQ RIDE and/or Rio Metro.

Part 7-4(H) On-street Parking

Section 7-4(H)(1) General Provisions

Space within the travel way may be allocated to meet the parking needs of adjacent businesses and land uses. On-street parking also provides a buffer between pedestrians and moving traffic, reduces the need for off-street parking, and can serve as a speed management technique. On-street parking is generally located alongside the curb.

7-4(H)(1)(i) On-street Parking Location

1. On-street parking is generally permitted on local streets unless prohibited or restricted by street signage.
2. On collectors and above, on-street parking is recommended within designated Centers, along Main Street Corridors, and near other high

- pedestrian activity areas. See [ABC Comp Plan](#) Table 7-5: Priority Street Element Matrix for recommendations for different Corridors.
3. On-street parking is generally prohibited outside of Centers and Main Street Corridors where posted vehicle speeds exceed 30 MPH and traffic volume is greater than 10,000 ADT, except at the discretion of the City Engineer.
 4. Outside of Centers, Main Street Corridors, and other high pedestrian-activity areas, the City Engineer in its sole discretion may consider on-street parking along arterial roadways in limited circumstances. Areas that may be considered include Metropolitan Redevelopment Areas and other locations that support economic development.
 5. Consideration of on-street parking may require studies of parallel routes, operating speeds, traffic volume, drainage concerns, sight lines, and available right-of-way.

7-4(H)(1)(ii) Types of On-street Parking

On-street parking options include reverse angle (also referred to as back-in angle), parallel, and head-in angle parking.

7-4(H)(1)(ii)(a) Reverse Angle Parking

1. Reverse angle parking is recommended by [ABC Comp Plan](#) Goal 7.4 Context-sensitive Parking for on-street parking where right-of-way permits. Reverse angle parking offers the clearest sightlines for motorists to see approaching bicyclists and other vehicles.
2. Where practical and where sufficient right-of-way exists, reverse angle parking should be used on bicycle routes, bicycle boulevards, and roadways with bicycle lanes.
3. Reverse angle parking is recommended on low-speed (25 MPH or less) and low-volume roadways.

7-4(H)(1)(ii)(b) Parallel Parking

1. Parallel on-street parking is recommended in locations with limited right-of-way and on higher volume streets.
2. Parallel parking is prohibited on streets with speed limits above 35 MPH.

7-4(H)(1)(ii)(c) Head-in Angle Parking

Head-in angle parking is the least preferred option, but may be used on roadways with speeds below 35 MPH and without bicycle facilities.

7-4(H)(1)(iii) ADA/PROWAG Accessible On-street Parking

See [Section 7-4\(K\)\(5\) ADA Accessible Parking](#) for ADA/PROWAG parking space dimensions. ADA/PROWAG accessible parallel on-street parking may be placed only where sufficient right-of-way exists for the loading/unloading area.

Section 7-4(H)(2) Design Guidance

7-4(H)(2)(i) General Provisions

1. The type of on-street parking treatment depends on the location, roadway conditions (e.g. vehicle travel speeds and traffic volume), Corridor designation or functional classification, and available right-of-way.
2. On-street parking may be combined with curb extensions to reduce pedestrian crossing distance, to create additional space in the landscape/ buffer zone, or to improve access to transit stops.
3. Adequate clear sight triangles must be provided for all on-street parking spaces.

7-4(H)(2)(ii) Reverse Angle Parking Design Guidance

1. Sufficient right-of-way is required to ensure 20 feet of clear roadway width located between the end of the parking stall and the face of curb or the parking stall on the opposite side of the street. (See [FIGURE 7.4.87](#).)
2. Signage demonstrating the appropriate technique is strongly recommended for reverse angle parking.
3. The preferred angle for reverse angle parking is 60°.
4. The stall width should accommodate a minimum 8.5 foot wide and 18 foot long vehicle space. See [FIGURE 7.4.87](#) and [TABLE 7.4.60](#) for dimensions of angled parking.
5. Parking barriers and/or extended shy zones in the landscape/buffer zone are recommended to ensure that vehicles with long rear overhangs do not reduce pedestrian access route or strike streetside elements.

FIGURE 7.4.87 Dimensions for Angle Parking

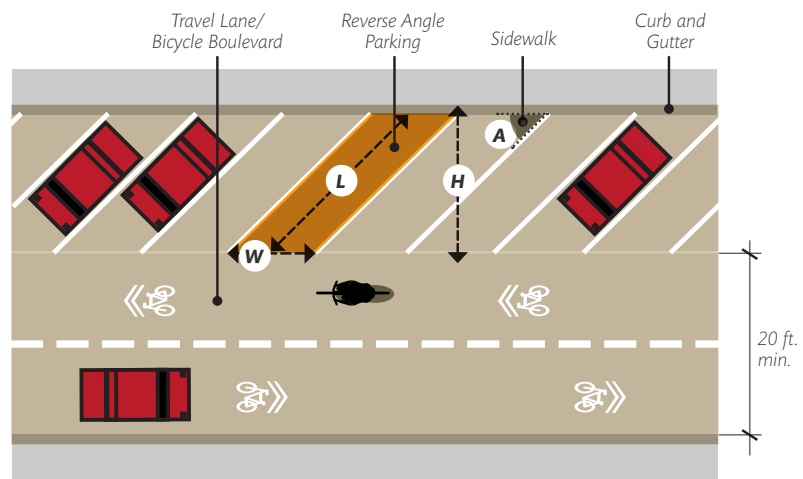

TABLE 7.4.60 Dimensions for Angle Parking

Angle (A)	Stall Length (L)	Stall Width (W)	Stall Depth (H)
45°	26.5 ft.	12 ft.	18.7 ft.
60°	22.9 ft.	9.8 ft.	11.5 ft.
75°	20.3 ft.	8.8 ft.	19.6 ft.

7-4(H)(2)(iii) Parallel Parking Design Guidance

1. The required width of on-street parallel parking stalls is 7 feet to 8.5 feet, with wider stalls recommended on commercial streets with higher levels of parking turnover and on streets with speeds greater than 25 MPH. (See [TABLE 7.4.61](#).)

TABLE 7.4.61 Minimum Parallel Parking Stall Width by Speed Limit

Speed Limit	Stall Width
25 MPH	7 ft.
30-35 MPH	8 ft.

2. The gutter pan may be used as part of the stall width.
3. Where parallel on-street parking is adjacent to a bicycle lane (and there is insufficient space for reverse angle parking), the minimum combined width for the bicycle lane and the parallel parking stall is 13 feet (with a recommended 7 foot wide parallel parking stall and a 6 foot wide bicycle lane).
4. The combined width of a parallel on-street parking stall and the adjacent travel lane should be a minimum of 18 feet.
5. A 1.5 foot shy zone space or offset shall be provided between the curb edge and any vertical elements in the landscape/buffer zone.
6. Individual stalls may be marked to increase the parking capacity. The minimum stall length is 20 feet for interior spaces and 18 feet for end spaces. (See [FIGURE 7.4.88](#).)
7. Per [MUTCD](#), there shall be a 20-foot long space between the crosswalk or pedestrian crossing and the nearest on-street parking space. A curb extension may be used within that 20 foot area.

FIGURE 7.4.88 Parallel Parking Dimensions

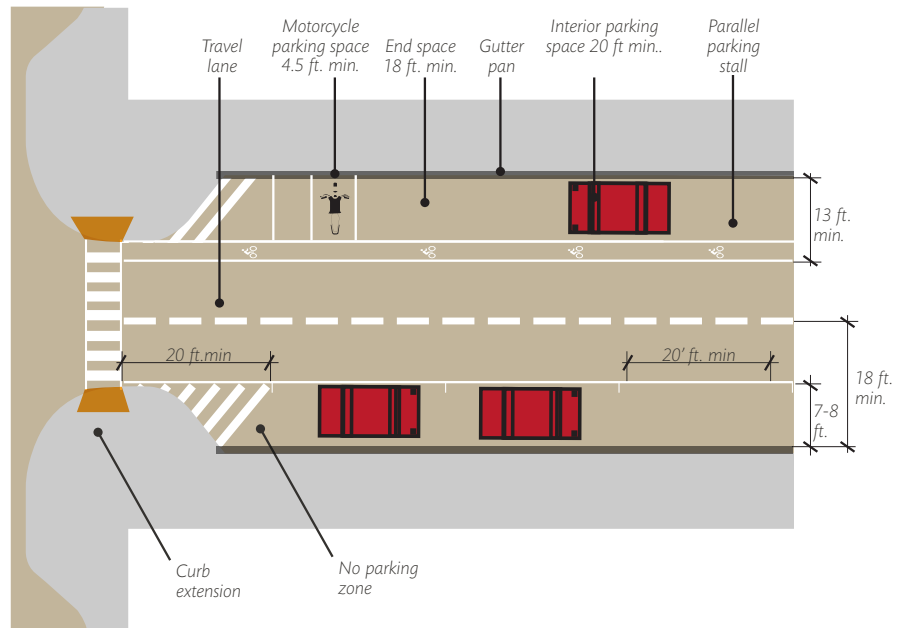

7-4(H)(2)(iv) Head-in Angle Parking Design Guidance

1. Recommended dimensions for angle parking are provided in [TABLE 7.4.60](#).
2. Additional guidance on head-in angle parking can be found in [ITE Designing Walkable Urban Thoroughfares](#) or other manuals approved by the City Engineer.

7-4(H)(2)(v) On-street Bicycle and Motorcycle Parking

1. Excess space between the end parking space nearest to an intersection and the no-parking zone may be striped for on-street motorcycle or bicycle parking. (See [FIGURE 7.4.88](#)).
2. On-street parking for motorcycles or bicycles may be used in lieu of a parking stall at the discretion of the City Engineer.
3. On-street motorcycle parking stalls should have a minimum width of 4.5 feet.
4. In areas where on-street parking is regulated by parking meters, at least 3 on-street parking spaces shall be designated as free motorcycle, moped, or motor scooter parking for every 3 contiguous blocks of metered on-street parking. This provision does not apply if it would require the removal of any regular on-street metered parking space.
5. Bicycle parking should be in the form of a corral or other vertical feature that clearly demarcates the space as intended for bicycles only. Corrals are most appropriate at street corners. (See [FIGURE 7.4.89](#) for examples.)

FIGURE 7.4.89 Bicycle Parking Corral Examples



Section 7-4(H)(3) Maintenance and Parking Agreements

7-4(H)(3)(i) Publicly Maintained On-street Parking

If the City elects to create on-street parking in the City right-of-way, the City will maintain the parking, including routine sweeping, debris removal, snow removal, ice removal, and any necessary re-striping and repaving

7-4(H)(3)(ii) Private Parking Agreements

1. If an applicant develops or redevelops on-street parking in City right-of-way for its exclusive use, then the applicant shall enter into a parking agreement with the City. The parking agreement shall require the applicant to pay an annual fee to the City for the right to post signs permitting private, exclusive parking, and shall require the applicant to construct and maintain the parking spaces, including the routine sweeping, debris removal, snow removal, ice removal, and any necessary re-striping. Under the parking agreement, the City may repave the parking spaces when repaving the adjacent roadway.
2. If an applicant develops or redevelops on-street parking in City right-of-way for public, non-exclusive use, then the applicant shall enter into a parking agreement with the City. The parking agreement shall not require the payment of an annual fee, but shall require the applicant to construct and maintain the parking spaces, including the routine sweeping, debris removal, snow removal, ice removal, and any necessary re-striping. Under the parking agreement, the City may repave the parking spaces when repaving the adjacent roadway.
3. If the construction of on-street parking is shared by the City and an applicant, the parties shall enter into a parking agreement concerning the maintenance responsibilities of each party and the collection and payment of any fees.

Section 7-4(H)(4) Creation of New On-street Parking During Development

7-4(H)(4)(i) Procedures

1. The addition of on-street parking to support a development may be permitted as described in [Subsection 7-4\(H\)\(1\)\(i\)](#). A pre-design meeting with the City Engineer to review the conceptual layout is required.
2. For approval of new on-street parking to support a development, all of the following criteria must be met:
 - a. *The parking and adjacent sidewalk must be within City right-of-way or a public easement.*
 - b. *Public notice must be given to property owners/tenants within 200 feet of the proposed parking area.*
 - c. *The posted speed must be less than 35 MPH.*
 - d. *A work order must be obtained for initial construction. Work orders require engineered plans. Barricading and excavation permits are required for the work order and for any maintenance.*
3. Meeting the above criteria does not guarantee approval if there is a significant safety issue that would be created by allowing on-street parking. If approval is granted by the City, this approval does not grant vested rights for on-street parking. The City retains the right, at its discretion, to remove on-street parking and the applicant shall agree to waive any claim of damage if on-street parking is removed. The standard criteria for on-street parking credits in [IDO Subsection 14-16-5-5\(C\)\(4\)\(e\), Parking & Loading](#) shall apply.

Section 7-4(H)(5) Parklets

7-4(H)(5)(i) Definitions and General Provisions

1. Parklets, also locally referred to as parquitos, are small public areas or commercial spaces supporting an adjacent business in which a curbside parking space is replaced with a seating area or gathering space that encourages additional activity along a street. Parklets may span 1 or more on-street parking spaces (or the equivalent curbside space).
2. Parklets are generally the result of an agreement between the City and the business or property owner that is converting the parking space for commercial purposes. Coordination with the Department of municipal Development Parking Division is required, including agreement over fees associated with lost parking revenue.
3. Parklets require approval by the City Engineer and a revocable permit or other agreement to convert a public parking space for commercial use.
4. The City reserves the right to reject a parklet if it will interfere with upcoming street improvements, affect drainage, or create challenges for street maintenance.
5. Construction and maintenance is the responsibility of the property owner converting the space.
6. Parklets are most appropriate on streets with speed limits of 25 MPH or less, and may be considered on streets with speed limits over 25 MPH on a case-by-case basis.
7. Parklets may be sited along the curb on streets where on-street parking spaces exist, or where sufficient space for on-street parking is available.

7-4(H)(5)(ii) Design Guidance

1. The width of the parklet must not be greater than the designated on-street parking spaces. (See [FIGURE 7.4.90](#).)
2. Parklets may not be constructed over access points for utilities, such as manhole covers or storm drain inlets, or in front of fire hydrants.
3. Parklets shall not be located at street corners and shall be located a minimum 20 feet from the edge of the on-street parking zone.
4. A minimum buffer of 4 feet is required between the edge of the parklet and the adjacent parking space(s).
5. A minimum 2 foot buffer is required between the edge of the parklet and any active driveway.
6. All parklets must comply with the ADA/PROWAG and be accessible to all users. Parklets are generally not permitted on streets with a grade greater than 5%, unless the parklet provides safe access for all users.
7. The parklet shall be flush against the curb or connected via an ADA/PROWAG accessible ramp.
8. A vertical separation from the adjacent roadway is required. The separation shall be located adjacent to the roadway as well as on both ends of the parklet.
9. Where a parklet is located next to a bicycle lane, there must be a minimum 5 feet of space from the edge of the parklet to the nearest general purpose travel lane.
10. All parklets shall accommodate street drainage.
11. All parklet designs shall be approved by the City Engineer and should reference the [San Francisco Parklet Manual](#) or approved alternative for additional considerations.

FIGURE 7.4.90 Parklet Location and Examples

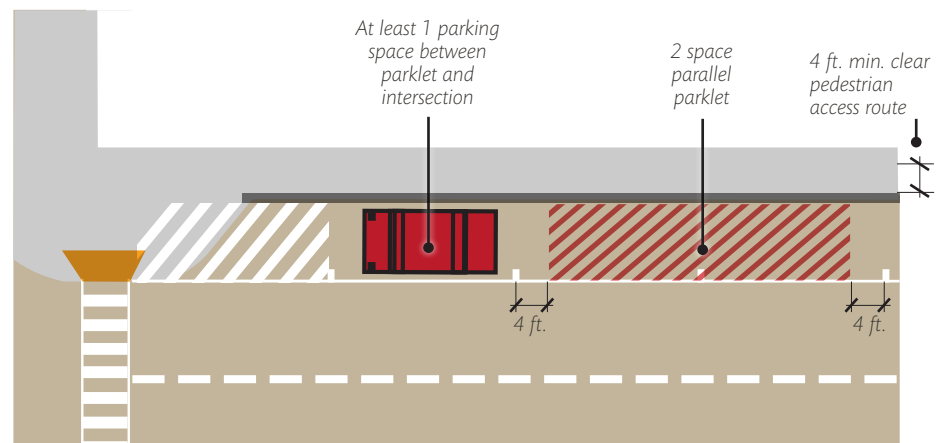

Part 7-4(I) Geometric Design Criteria

The criteria in this section are major controlling factors in the design of streets. Designers shall carefully apply these criteria to individual design circumstances. Suitable transitional elements must be provided between changes in geometric configuration, pavement, curb, and drainage carrying aspects of the ultimate street design.

The following criteria are discussed in this section:

1. General Design Criteria
2. Horizontal Alignment
3. Superelevation
4. Vertical Alignment
5. Sight Distance
6. Intersection Design
7. Medians and Turn Lane Design

The standards contained in the DPM are intended to provide direction in the design of transportation facilities. While most of the design parameters that should be used are provided in the following pages, unusual conditions may occur in some projects.

Where additional guidance and explanation is needed, the designer should refer to the current version of publications from the following sources:

1. AASHTO
2. ITE
3. NACTO

Specific publications that may be referenced in the design process include:

1. AASHTO, [Roadside Design Guide](#)
2. Transportation Research Board, [HCM](#)
3. Federal Highway Administration, [MUTCD](#)
4. U.S. Access Board, [PROWAG](#)

NOTE: Many of the tables contained in this section are taken from the 6th edition (2011) of the AASHTO publication, *A Policy on Geometric Design of Highways and Streets (the AASHTO Green Book)*. Equivalent tables from updated versions of the AASHTO Green Book should be referenced when they become available.

Section 7-4(I)(1) General Design Criteria

Streets shall be designed to avoid long straight segments on residential streets and abrupt, inconsistent changes in either horizontal or vertical alignment. Balance is necessary to avoid hazardous situations and help meet driver expectations.

The fundamental approach to street design is to first identify the design speed for the facility. (See [TABLE 7.2.29](#).) The nominal vehicle type must also be considered. The design is accomplished by selecting the appropriate characteristics to accommodate the design vehicle at the design speed in a safe and efficient manner.

Section 7-4(I)(2) Horizontal Alignment

Normal crown is generally preferred in urban streets to promote control of drainage and nuisance stormwater flows. This preference will lead to the use of longer radius horizontal curves in most major street circumstances.

[TABLE 7.4.62](#) provides the minimum centerline radius for a normal road with a 2% crown or 2% maximum cross slope. For roads with superelevation, cross slopes greater than 2%, and design speeds greater than 45 MPH, refer to the current [AASHTO Green Book](#).

TABLE 7.4.62 Minimum Centerline Radius for a Normal Road*

Design Speed (MPH)	Radius (ft.)
15	50
20	107*
25	198*
30	333
35	510
40	762
45	1039

* A local residential street with 90° or near 90° turns may be designed with a minimum centerline radius of 75 with the approval of the Traffic Engineer.

Section 7-4(1)(3) Superelevation

The use of superelevation (i.e. outside edge of pavement higher than inside edge) should be limited in an urban setting due to the lower speeds of the roadways. Superelevation shall not be used on local streets. Refer to the current [AASHTO Green Book](#) for guidance on superelevation rates.

The use of superelevation requires the careful design of transitions leading to/from normal crown sections to and from superelevated sections. Designs involving such transitions should show sufficient detail to demonstrate that drainage is being accommodated (i.e. no low points) and to provide sufficient information for adequate construction staking to ensure the desired result. Vertical profile lines for all curblines as well as detailed superelevation run-out plans shall be provided for superelevation design. See [FIGURE 7.4.91](#) for a visual representation of a superelevation runout plan.

FIGURE 7.4.91 Example Superelevation Runout Plan

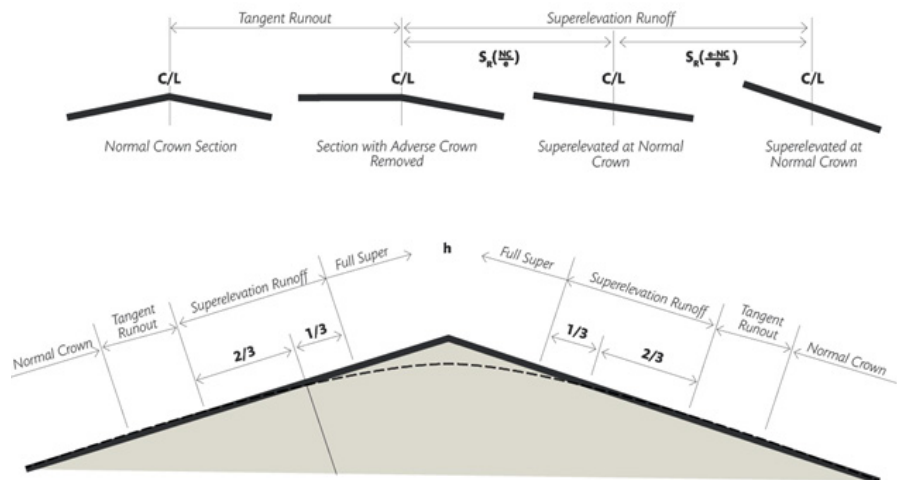

Section 7-4(l)(4) **Vertical Alignment**

Long, flat gradients are undesirable because of poor drainage characteristics. The minimum desirable gradient consistent with acceptable drainage is 0.5 percent and, as such, should be observed as a general design principle. Long, steep gradients are also undesirable since they are difficult for heavier vehicles to negotiate at desirable traffic speeds. See [DPM Article 6-9 Street Hydraulics](#) for additional requirements.

Vertical curve criteria in [TABLE 7.4.63](#) are from the [AASHTO Green Book](#), 6th edition. In the application of these criteria, the designer will be expected to apply sound engineering judgment in combining vertical geometry with horizontal geometry. Extreme vertical undulation is not acceptable. Vertical changes in grade occurring simultaneously with horizontal alignment changes must be carefully considered to preserve the required sight distance consistent with the design speed of the street. Horizontal curvature should not be introduced at or near the top or bottom of a crest or sag vertical curve. Intersection sight distances must be maintained in all designs. Intersections on vertical curves should be placed at the crest where visibility in both directions can be maintained.

The values for K shown in the following tables for Crest and Sag Vertical Curves are to be used in determining the minimum length of vertical curve required by the use of the relationship

$$\text{EQUATION 7.5 } \mathbf{L = K \cdot A}$$

where:

L = Length of vertical curve in feet

A = Algebraic difference in grades expressed in percent

K = Design value indicative of rate of curvature

Lengths of vertical curves longer than the minimums resulting from the use of K values shown should be used wherever possible; however, K should not exceed 167 feet when curb and gutter is used.

If grade changes without vertical curves are used, as allowed in the following table, a minimum of 50 feet must be maintained between the vertical point of intersections.

TABLE 7.4.63 Design Controls for Vertical Curves

	Design Speed (MPH)	Minimum Length Vertical Curve (ft.)	K Value For Crest Stopping Sight Distance	K Value For Sag Stopping Sight Distance	Maximum Grade Change Allowed Without Vertical Curve	Maximum Grade Allowed %
Arterials/ Collectors	50	150	84	96	0.4	6
	45	135	61	79	0.4	7
	40	135	44	64	0.4	7
	35	100	29	49	0.7	8
Major Local	30	100	19	37	0.8	8
Local Residential	25	75	12	26	1	8
Local Residential: Access Streets, Cul-de-sacs, Alleys	20	60	7	17	1	12
Local Leg of T Intersection	15	45	3	10	1	12
Local Industrial / Commercial	30	90	19	37	1	8

Section 7-4(l)(5) Sight Distance

7-4(l)(5)(i) General Provisions

1. Roadways, intersections, site entrances, and driveways shall have sufficient visibility to allow motorists to easily travel and enter or exit safely, as well as protect pedestrians and bicyclists.
2. Visibility must be maintained in accordance with the current AASHTO guidelines for roadway design intersection visibility. The information below is based on the 6th Edition of the [AASHTO Green Book](#).
3. Depending on specific site conditions, adjustments to sight distances may be required. These factors may include, but are not limited to, side street approach grades greater than 3%, median widths of the crossing street, or skewed intersections. Waivers may also be granted in Downtown, Urban Centers, and Mixed-use zone districts.

7-4(l)(5)(ii) Stopping Sight Distance

1. Stopping sight distance is the length of roadway visible to the driver. The minimum sight distance available on the roadway should be sufficiently long to enable a vehicle traveling at or near the design speed to stop or change lanes before reaching a stationary object in its path.
2. The method of measuring stopping sight distance along a roadway is illustrated in [FIGURE 7.4.92](#).

3. Minimum stopping sight distances, as shown in [TABLE 7.4.64](#), shall be provided in both the horizontal and vertical planes for planned roadways as related to assumed driver's eye height and position.
4. Adequate sight distance shall be provided at all driveway access points.
5. Where there are sight obstructions (such as walls, cut slopes, buildings, or other hazards) on the inside of curves, changes in roadway alignment may be required to obtain adequate stopping sight distance if the sight obstruction cannot be removed.

FIGURE 7.4.92 Stopping Sight Distance

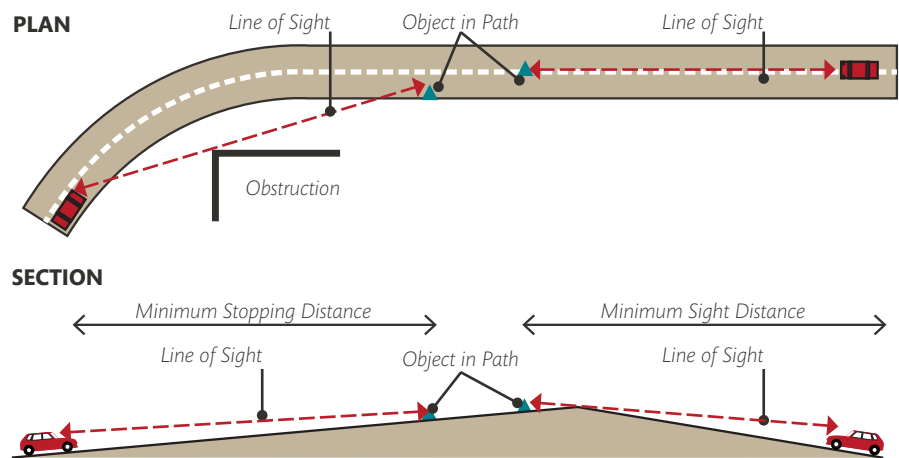

TABLE 7.4.64 Minimum Stopping Sight Distance							
Design Speed (MPH)	Upgrades			Flat	Downgrades		
	9%	6%	3%		0%	-3%	-6%
25	140 ft.	145 ft.	150 ft.	155 ft.	160 ft.	165 ft.	175 ft.
30	180 ft.	185 ft.	200 ft.	200 ft.	205 ft.	215 ft.	230 ft.
35	225 ft.	230 ft.	240 ft.	250 ft.	260 ft.	275 ft.	290 ft.
40	270 ft.	280 ft.	290 ft.	305 ft.	315 ft.	335 ft.	355 ft.
45	320 ft.	330 ft.	345 ft.	360 ft.	380 ft.	400 ft.	430 ft.
50	375 ft.	390 ft.	405 ft.	425 ft.	450 ft.	475 ft.	510 ft.

7-4(l)(5)(iii) Intersection Sight Distance

1. Intersections should be planned and located to provide as much sight distance as possible. A basic requirement for all controlled intersections is that drivers must be able to see the control device well in advance of performing the required action. Stopping sight distance on all approaches is needed at an all-way stop. Obstruction-free sight triangles shall be provided for both left and right turns.
2. Intersections of local streets with major streets classified as collector or above shall not be located at or near horizontal curves without special evaluation of intersection sight distance. The location of an intersection on the inside of a horizontal curve is a situation that will typically result in intersection visibility problems. The location of any property lines, fences, or other obstructions will need to be evaluated to ensure that the minimum sight distance is maintained. See Figure 9-15 Intersection Sight Triangles in the [AASHTO Green Book](#), 2011 or latest edition.
3. Adjustments to the intersection sight distance must be made for side street approach grades greater than 3%, skewed intersections, and other types of roadway geometry in accordance with Section 9.5.3 Intersection Control in the [AASHTO Green Book](#), 2011 or latest edition.
4. At any intersection of 2 roadways, a sight triangle shall be provided for an unobstructed path of sight. The sight distance triangle can be defined by connecting a point that is along the minor street's edge of pavement and 15 feet from the edge of pavement of the major street, with a point that is distance (L) along the major street's edge of pavement as shown in [FIGURE 7.4.93](#).
5. [TABLE 7.4.65](#) summarizes the required sight distance (L) along the major road for a stopped vehicle on the minor street to cross the major street. If a roadway is divided with a median width of 20 feet or more for passenger vehicle crossings or 40 feet or more for truck crossings, the required sight distance may be based on a two-stop crossing and consideration given to the width of each one-way section at a time.

FIGURE 7.4.93 Intersection Sight Distance

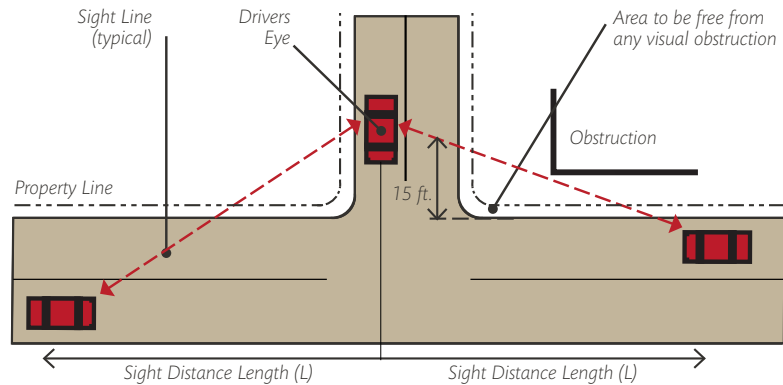

TABLE 7.4.65 Minimum Intersection Sight Distance

Speed Limit (MPH)	Minimum Intersection Sight Distance					
	2 Lane Undivided		3 Lane Undivided or 2 Lane Divided w/ 12 ft. Median		4 Lane Undivided	
	Left Turn	Right Turn	Left Turn	Right Turn	Left Turn	Right Turn
20	230 ft.	200 ft.	240 ft.	200 ft.	250 ft.	200 ft.
25	280 ft.	240 ft.	300 ft.	240 ft.	320 ft.	240 ft.
30	340 ft.	290 ft.	360 ft.	290 ft.	380 ft.	290 ft.
35	390 ft.	340 ft.	420 ft.	340 ft.	440 ft.	340 ft.
40	450 ft.	390 ft.	480 ft.	390 ft.	500 ft.	390 ft.
45	500 ft.	430 ft.	530 ft.	430 ft.	570 ft.	430 ft.
50	560 ft.	480 ft.	590 ft.	480 ft.	630 ft.	480 ft.

7-4(l)(5)(iv) Mini Clear Sight Triangle

Driveways need to maintain the mini clear sight triangle as shown in [FIGURE 7.4.94](#). This triangle starts at the sidewalk and measures 11 feet on a side.

FIGURE 7.4.94 Mini Clear Sight Triangle

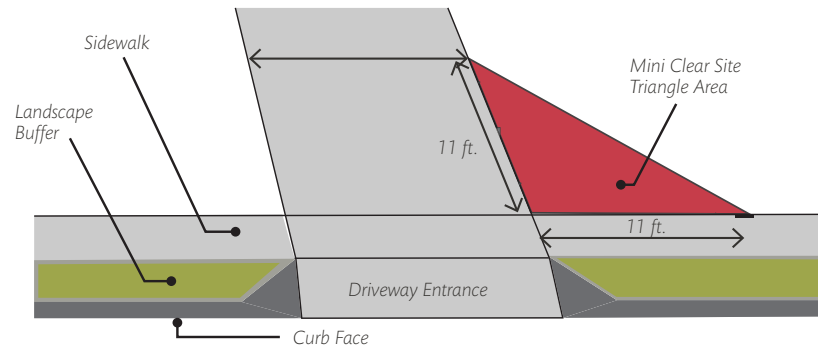

7-4(I)(5)(v) Visibility for Site Entrances and Driveways

Site entrances and driveways shall be designed to preserve the clear sight triangle free of visual obstruction as described in [Subsection 7-4\(I\)\(5\)\(iii\) Intersection Sight Distance](#) and [Subsection 7-4\(I\)\(5\)\(iv\) Mini Clear Sight Triangle](#) above.

7-4(I)(5)(vi) Sight Distance Note

The following note is required on all site plans: "Landscaping, signage, walls, fences, trees, and shrubbery between 3 feet and 8 feet tall (as measured from the gutter pan) are not allowed within the clear sight triangle."

7-4(I)(5)(vii) Objects Permitted in the Clear Sight Triangle

Objects that may be located in the clear sight triangle include, but are not limited to, hydrants, utility poles, utility junction boxes, and traffic control devices, provided that these objects are located to minimize visual obstruction. Objects under 8 inches wide may be allowed by the City Engineer.

Section 7-4(I)(6) Intersection Design

7-4(I)(6)(i) Intersection Traffic Control Typologies

7-4(I)(6)(i)(a) General Provisions

1. Traffic control is applied at all locations where two or more roads intersect to manage the movement of multiple users and directions of traffic. The traffic control technique depends on the traffic volume, Corridor type, and functional class of the roadways, with greater control required on higher speed and higher use facilities.
2. All traffic control devices should be designed in accordance with the standards and specifications as published in the most recent versions of the [MUTCD](#) and [City Standard Specifications](#).

7-4(I)(6)(i)(b) Signalized Intersections

1. A signal warrant analysis is required before a new traffic signal is added. See [Article 7-5 Traffic Studies](#) for further guidance.

2. Traffic signals may be removed and/or converted to a stop sign-controlled intersection if a signal warrant analysis is conducted and determines that a signalized intersection is unnecessary.
3. Where a development will cause traffic that warrants a signal, the developer will be financially responsible for all or a portion of the signal installation at the discretion of the City Engineer.
4. Guidance on the spacing of signalized intersections and signalized pedestrian crossings is provided in [Part 7-4\(A\) Network Connectivity](#).

7-4(I)(6)(i)(c) Unsignalized Intersections

1. An unsignalized intersection is an at-grade intersection in which the flow of traffic is not controlled by a traffic signal. Unsignalized intersections may be stop-sign controlled, yield sign-controlled, or uncontrolled.
2. Unsignalized intersections are appropriate for locations where the vehicle and/or pedestrian volumes do not meet the thresholds set forth for new signals in the [MUTCD](#).
3. The typical unsignalized intersection control shall be two-way stop control, which provides stop control on the secondary intersection approaches (i.e. side-street) and free flow on the primary street.
4. All-way stop control may be provided at intersections where traffic volumes or other conditions are consistent with the warrants set forth in the current edition of the [MUTCD](#).
5. Yield sign controls may be placed as part of the entrance to a traffic circle, roundabout, channelized right turn, or at the intersection approach of a minor road.
6. Uncontrolled intersections (i.e. intersections without any signage or traffic control) are generally discouraged and are only appropriate at the intersection of 2 local streets.

7-4(I)(6)(i)(d) Neighborhood Traffic Circles

1. Traffic circles are small raised islands placed in intersections around which traffic circulates. Traffic circles are intended to manage speeds in neighborhood settings by impeding through movements and forcing drivers to travel at slower speeds through intersections.
2. Yield signs may be used as traffic control at the approaches of the traffic circle.
3. Traffic circles are most appropriate at intersections on local and major local streets where large vehicle traffic is not a major concern but speeds, volumes, and safety are recorded problems. Additional guidance on neighborhood traffic circles is provided in [Part 7-4\(L\) Traffic Calming](#) and the [NTMP](#).

7-4(I)(6)(i)(e) Roundabouts

1. Roundabouts are a form of intersection control in which motorists and bicyclists travel counter-clockwise around a center island and yield at entry points to traffic already circulating the roundabout.
2. A roundabout may be constructed at intersection locations along collectors and arterials where it may be desired in order to enhance intersection capacity, reduce vehicle speeds along a corridor, reduce the incidences of severe crashes, address irregular intersection geometry, or enhance intersection aesthetics. Roundabout design and bicycle and pedestrian accommodations shall be designed in accordance with the criteria set forth in the most recent version of the [FHWA NCHRP Report](#)

- [672: Roundabouts: An Informational Guide](#), or a more recent comparable document acceptable to the City Engineer.
3. Care should be taken to ensure that roundabouts are not located in close proximity to adjacent stop or signal controlled intersections where long queues may back up into the roundabout.
 4. Additional right-of-way may be required for the construction of roundabouts. The purchase of right-of-way shall be considered as part of the design cost for roundabouts proposed on existing facilities.
 5. See the current [MUTCD](#) for guidance on signage and pavement markings for bicyclists and pedestrians at roundabouts. Per the [MUTCD](#), bicycle lanes are not permitted in roundabouts.
 6. See [NACTO](#), [AASHTO](#), or other approved design guides for pedestrian and bicycle design considerations through roundabouts.

7-4(I)(6)(ii) Intersection Design Considerations

7-4(I)(6)(ii)(a) Angle of Intersections

1. Streets shall be designed to intersect at right angles.
2. If an angled intersection is unavoidable, the acute angles at intersections for all new streets shall be 80° or greater. Consult the [AASHTO Green Book](#) for additional guidance on the effects of skewed intersections, including changes to the sight triangle and curb radii.
3. Intersections at less than 80° require permission from the City Engineer.
4. Direction on intersection spacing is provided in [Section 7-4\(I\)\(7\)](#).

7-4(I)(6)(ii)(b) Spacing of Intersections

Guidance on the spacing of signalized and unsignalized intersections is provided in [Part 7-4\(A\) Network Connectivity](#).

7-4(I)(6)(ii)(c) Intersection Grading

5. Intersections must be graded to provide characteristics consistent with the design speed of the through street. Projected curb flowline profiles through the intersection will be required for design review of intersections involving arterial and collector streets. Alignment of arterial streets through intersections must be continuous without breaks in grade and meet the criterion for vertical curvature in [TABLE 7.4.63](#). Grades within the intersection need to be flat enough to minimize problems with turning vehicles and to keep stopping distances reasonable. Grades should also be steep enough to ensure that proper drainage occurs. Grades should be between 0.5% and 3%.
6. Minor leg approach tangent gradients to intersections should not exceed 4% from the projected curb flowline of the through street. Deviations from this standard will require approval by the City Engineer.
7. Street crowns should be reduced through intersections to promote driver comfort. Additional guidance on drainage requirements at intersections is provided in [Chapter 6](#).

8. Grades intended to serve as drainage water blocks may only be designed on minor approach legs of intersections. Design of water blocks shall be per [Chapter 6](#) and the approved grading and drainage plan.
9. The designer should specifically investigate intersection design to assure that design flows will not overtop curbs resulting in damage outside the right-of-way. Drop inlets should be located away from curb access ramps. Curb returns should be designed to avoid ponding.
10. Intersections should be located so as to avoid roadway segments that are highly superelevated. Intersection grading for superelevated roadways needs to take into account the issues of grade compatibility, cross-over crown, etc. to ensure that the intersection will operate properly.

7-4(I)(6)(ii)(d) Intersection Sight Distance

Intersections should be designed to ensure that drivers have an unobstructed view as they approach or depart an intersection. Standards related to intersection sight distance are provided in [Section 7-4\(I\)\(5\)](#)

7-4(I)(6)(ii)(e) Bicycle and Pedestrian Accommodations

1. Additional guidance for bicycle travel at intersections is provided in [Part 7-4\(F\) Bikeways and Trails](#).
2. Additional guidance on sidewalks, curb ramp design, intersection pavement markings, and crosswalk design is provided in [Part 7-4\(E\) Pedestrian Facilities](#).

7-4(I)(6)(ii)(f) Intersection Turn Lanes

Additional guidance on turn lane design at intersections is provided in [Section 7-4\(I\)\(7\)](#).

7-4(I)(6)(iii) Curb Return Radii

7-4(I)(6)(iii)(a) Definition

Curb returns are the curved corner formed by the intersection of 2 streets. Curb returns guide motor vehicle during turning movements, and are important for delineating pedestrian zones at intersections.

FIGURE 7.4.95 Standard Curb Return Radii Diagram

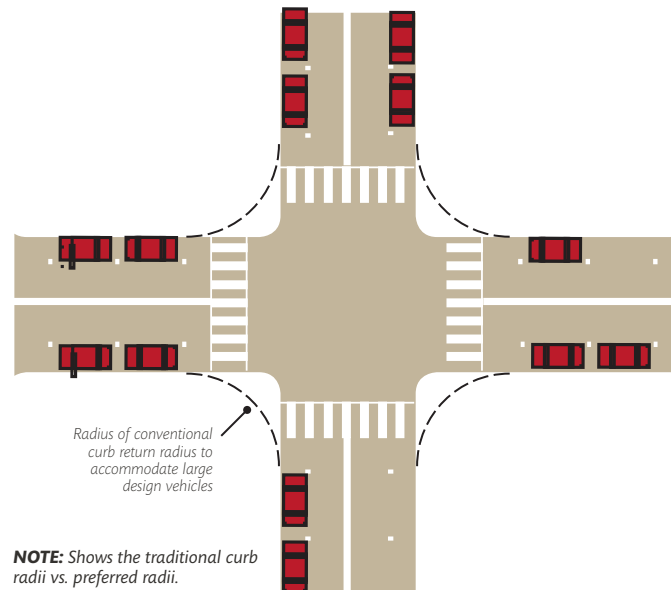

7-4(I)(6)(iii)(b) Design Considerations

1. Recommended ranges for curb return radii are provided in [TABLE 7.4.66](#).
2. Important factors for determining the size of curb return radii are the Corridor type and the location (i.e. inside or outside of a Center). Curb return radii should be designed to ensure safe movement for all roadway users.
3. Desired curb return radii are organized by Corridor type in [TABLE 7.4.66](#). The intersections of Corridors that carry higher traffic volumes at greater speeds generally have larger curb return radii. Turning radii of design vehicles should be checked during design. It is assumed that trucks and buses may need to swing wide to make right turns, but the design should discourage this movement where feasible. It is also assumed that large vehicles will turn into the middle or far lane if more than 1 lane is available.
4. Curb return radii are provided as ranges to ensure some flexibility, though the size of curb return radii should be minimized where possible. Smaller radii reduce vehicle speeds and reduce pedestrian crossing distance, and are recommended in Centers and Premium Transit station areas and along Multi-modal, Main Street, and Major Transit Corridors.
5. The design vehicle is generally an SU-30, though a smaller design vehicle is encouraged where feasible.
6. Curb return radii may be 15 feet or less within all designated Centers, regardless of Corridor type. If a 15 foot radius cannot be achieved in Centers or along desired Corridors, the curb return radius shall be the low value provided in [TABLE 7.4.66](#).
7. The design standards for curb return radii reflect that local streets may serve commercial and industrial purposes, in which case larger radii may be required to support delivery vehicles and other large trucks.
8. Larger radii are appropriate in locations where large vehicles, including buses and delivery trucks, make regular turning movements.

TABLE 7.4.66 Curb Return Radii Table

From/To	Commuter	Major Transit	Multi Modal	Main Street	Other Arterial	Minor Arterial	Collector	Local Commercial	Local Residential
Commuter	30-35 ft.	25-30 ft.	25-30 ft.	25-30 ft.	25-30 ft.	25-30 ft.	25-30 ft.	25-30 ft.	25-30 ft.
Major Transit	25-30 ft.	25-30 ft.	20-25 ft.	20-25 ft.	20-25 ft.	20-25 ft.	20-25 ft.	20-25 ft.	20-25 ft.
Multi Modal	25-30 ft.	20-25 ft.	20-25 ft.	20-25 ft.	20-25 ft.	20-25 ft.	20-25 ft.	20-25 ft.	20-25 ft.
Main Street	25-30 ft.	20-25 ft.	20-25 ft.	15-20 ft.	20-25 ft.	20-25 ft.	15-20 ft.	15-20 ft.	15-20 ft.
Other Arterial	25-30 ft.	20-25 ft.	20-25 ft.	20-25 ft.	25-30 ft.	20-25 ft.	20-25 ft.	20-25 ft.	20-25 ft.
Minor Arterial	25-30 ft.	20-25 ft.	20-25 ft.	20-25 ft.	20-25 ft.	20-25 ft.	20-25 ft.	20-25 ft.	20-25 ft.
Collector	25-30 ft.	20-25 ft.	20-25 ft.	15-20 ft.	20-25 ft.	20-25 ft.	15-20 ft.	15-20 ft.	15-20 ft.
Local Commercial	25-30 ft.	20-25 ft.	20-25 ft.	15-20 ft.	20-25 ft.	20-25 ft.	15-20 ft.	15-20 ft.	10-15 ft.
Local Residential	25-30 ft.	20-25 ft.	20-25 ft.	15-20 ft.	20-25 ft.	20-25 ft.	15-20 ft.	10-15 ft.	10-15 ft.

7-4(I)(6)(iii)(c) Effective Curb Radius

The presence of bicycle lanes, bicycle buffers, and/or on-street parking can increase the “effective” radius, which takes into account the available space for a turning movement, rather than just the curb return itself. Curb returns may be designed according to the effective curb radius rather than the actual curb radius.

FIGURE 7.4.96 Effective Curb Return Radii Diagram

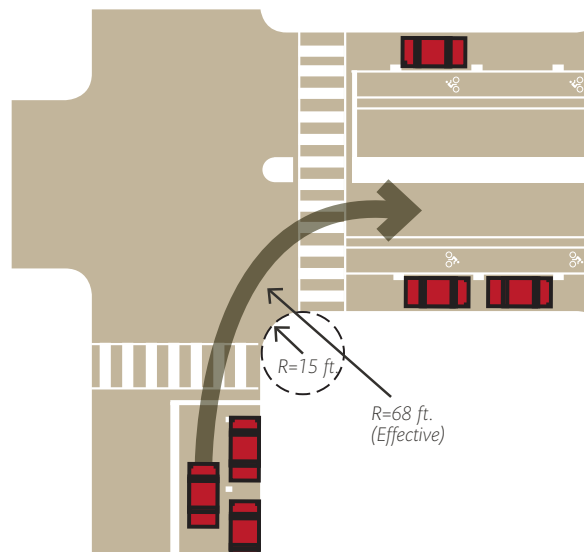

7-4(I)(6)(iii)(d) Curb Extensions

1. Where on-street parking lanes are provided, curb extensions may be considered for reducing the effective crosswalk width for pedestrians.
2. Curb return radii may be adjusted to allow sidewalk curb extensions for street crosswalk areas at intersections with local residential streets.

7-4(I)(6)(iii)(e) Freight Accommodations

1. Curb return radii may be increased along corridors with high levels of freight travel, or if 1 or more of the streets in question is impacted by a major freight traffic generator. In these cases, the curb return radii should correspond to a larger design vehicle.
2. For roundabouts, designers may consider incorporating mountable curbs, truck aprons, or other features that avoid the need for larger radii.

7-4(I)(6)(iii)(f) Channelized Right Turn Lanes

1. Channelized right turn lanes accommodate high levels of turning movements and encourage turning movements at higher speeds. Channelized right turns may be acceptable in locations with limited pedestrian activity and in locations where efficient traffic flow is particularly desirable, such as a Commuter Corridor. Channelized right turn lanes should not be a standard design feature in high-pedestrian activity areas.
2. If such a turn lane is considered necessary, the designer should consult an accepted national design manual, including [ITE Designing Walkable Urban Thoroughfares](#), and the City Engineer.
3. Additional guidance about restricted turning movements is provided in [Section 7-4\(I\)\(7\)](#).

Section 7-4(I)(7) Median and Turn Lane Design

7-4(I)(7)(i) Medians

7-4(I)(7)(i)(a) Definitions and General Provisions

1. Medians are the center portion of the roadway that separates general purpose travel lanes moving in opposite directions. Medians frequently incorporate features to improve safety and operations by providing space for turning vehicles.
2. Center turn lanes may be incorporated as part of a median and interspersed with median islands. Medians may also serve as pedestrian or bicycle refuges, whether as raised features or through physical barriers, pavement markings, and signage that distinguishes the pedestrian safe zone as part of a designated crossing. Options for medians and center turn lanes include:
 - a. Two-way left-turn lanes (TWLTL)
 - b. Raised medians with intersection turn bays
 - c. Median refuges for pedestrians and cyclists
 - d. Raised landscaped medians
3. Some form of raised or striped median is strongly preferred on principal and minor arterials, with wider medians required along segments with turn bays.

4. Median landscaping and pedestrian refuges are desirable in high pedestrian activity areas and as space allows.

7-4(I)(7)(i)(b) Design Considerations

1. Median widths are measured from curb face to curb face or center of pavement stripe to center of pavement stripe.
2. Median refuges shall be a minimum 6 feet wide, with a preferred width of 8 feet to 10 feet. Additional guidance on median refuge islands is provided in [Part 7-4\(E\) Pedestrian Facilities](#). Additional guidance on See [Article 7-4 Design Standards](#) for guidance on pedestrian crossing locations.
3. For collector and arterial roadways where the median also serves as center turn lane space, the median turn lane width should be 10 feet to 12 feet, with wider turn lanes appropriate on higher speed roadways (i.e. above 35 MPH) and with an additional 2 feet to 4 feet separating traffic as indicated in [FIGURE 7.4.97](#).
4. Narrow medians (i.e. less than 6 feet) are most appropriate for restricting turning movements and separating opposing traffic, and may be used for some landscaping purposes.
5. Medians should be a minimum of 6 foot wide for the placement of traffic signals.
6. Trees generally require a minimum 6 foot wide median. Placement and maintenance of street trees as part of median landscaping should ensure adequate clear zone and sight distance. See the current AASHTO [Roadside Design Guide](#) for clear zone recommendations, [Subsection 7-4\(I\)\(5\)\(iv\)](#) for sight distance requirements, and [Chapter 11 Landscape and Irrigation](#) for additional guidance on landscaping requirements.
7. Additional guidance on median-running transit infrastructure is provided in [Part 7-4\(G\) Public Transit](#).
8. Raised medians may require drainage infrastructure, including a curb and gutter pan and drop inlet. See [Chapter 6 Drainage, Flood Control, and Erosion Control](#) for drainage requirements.

FIGURE 7.4.97 Median with Center Turn Lane

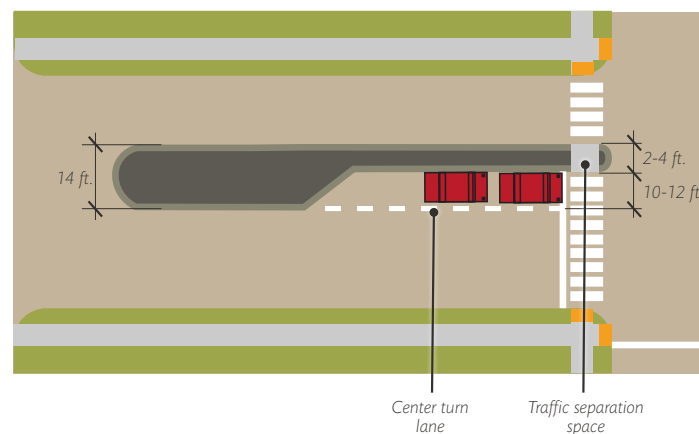

7-4(I)(7)(ii) Median Openings

7-4(I)(7)(ii)(a) Definitions and General Provisions

1. Median openings, or median cuts, are an unobstructed section of a raised median that allow for left turns. Raised medians generally improve safety and traffic operations but reduce site access.
2. The frequency of median openings depends on the corridor type and the surrounding land use context.
3. Medians and access limitations shall be consistent with all restrictions contained in the [MRCOG Inventory of Roadway Access Limitations](#).

7-4(I)(7)(ii)(b) Spacing and Access Control

4. Recommendations for spacing curb cuts and driveway frequency is provided in [Part 7-4\(B\) Site Access Points](#).
5. Median openings shall follow guidance from [Article 7-4 Design Standards](#) and [Section 7-4\(I\)\(6\)](#).
6. Where a median opening is desired, access to both sides of the street shall be considered. If development exists on both sides of the street, left-turn bays for both directions may need to be constructed.
7. Where an access point exists on the opposite side of the street, the centerline of the new access points shall be as closely aligned as conditions allow.
8. If access points cannot be aligned, it is desirable to have them offset so potential left turn paths do not cross and [AASHTO Case F Sight Distance](#) is accommodated.
9. The minimum distance between the ends of adjacent median openings is 300 feet on local streets and collectors and 400 feet on minor arterials and principal arterials, with greater distances preferred on Commuter Corridors and other roadways where vehicle throughput is highly prioritized, as determined by the City Engineer. See [FIGURE 7.4.98](#).

FIGURE 7.4.98 Median Opening Spacing

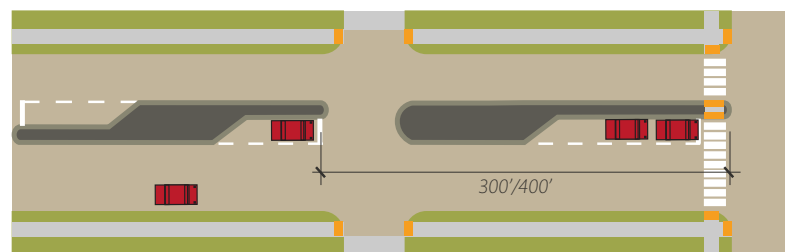

10. Only 1 road or driveway on each side of the roadway shall be served by the median opening. Where a property line falls within the median opening area, a common drive serving both properties shall be used.
11. A median opening will not be created or approved automatically because it meets the spacing requirements. The type of development, internal circulation and traffic operating conditions (existing or projected) on the street shall also be considered.
12. Consolidation of median openings should be considered during roadway reconstruction projects.

7-4(I)(7)(ii)(c) Design Considerations

1. Approval by the NMDOT is required for all median openings along state-owned and maintained roadways.
2. The construction of appropriate left-turn lanes must be included with any new median opening. The length of the turn bay approaching the median opening shall allow for anticipated queueing needs.
3. Additional guidance on turn lane design is provided in [Subsection 7-4\(I\)\(7\)\(iii\)](#).
4. All median opening designs must address drainage needs.

7-4(I)(7)(ii)(d) Median Opening Requests

1. Median cuts require approval by the City Engineer.
2. A work order shall be obtained for construction. Work orders require engineered plans and may be obtained from the DRC. Construction is the responsibility of the applicant.
3. Depending on the size of the development, a traffic scoping report or traffic impact study may be required for a median opening to be created. (See [Article 7-5 Traffic Studies](#).)

7-4(I)(7)(iii) Turn Lanes

7-4(I)(7)(iii)(a) Definitions and General Provisions

1. Separate turn lanes expedite the movement of through traffic, increase roadway capacity, allow the controlled movement of turning traffic, and promote the safety of all traffic.
2. Turn lanes for right and left turns into a driveway or street may be necessary for safety and capacity reasons, where roadway speeds and traffic volumes are high, or if there are substantial turning volumes.

7-4(I)(7)(iii)(b) Turn Lane Warrants

1. A turn lane or a taper is required on streets where the turn lane warrants in [TABLE 7.4.67](#) are exceeded in the AM or PM peak. At locations that do not exceed the criteria, the City Engineer may still require a turn lane or taper to address known safety concerns.
2. The City may require additional turn lanes, tapers, or other improvements when the City Engineer believes that the absence of such improvement will create an unsafe condition.
3. Left-turn lanes shall be required if a drivepad or access point with a median opening is constructed. The turn lane shall provide for both the storage and deceleration of turning vehicles, where feasible.
4. Additional right-of-way for turn lanes, deceleration lanes, or tapers may need to be dedicated, as determined by the City Engineer.

Left Turn		Right Turn	
Design Speed (MPH)	Turning Volume per Hour	Design Speed (MPH)	Turning Volume per Hour
25	50	25	60
30-40	40	30-40	50
45	30	45	45

7-4(I)(7)(iii)(c) Turn Lane Design

1. The design elements that make up a turn lane are shown in [FIGURE 7.2.41](#).

FIGURE 7.4.99 Turn Lane Design Elements

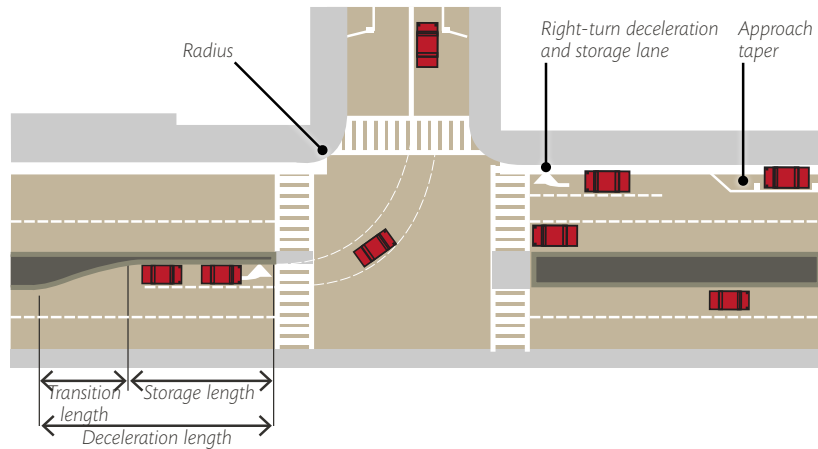

2. Turn lanes shall be designed based primarily on the following:
 - a. The length needed for drivers to decelerate to a speed that allows safe turning into the driveway or side street.
 - b. The amount of vehicular storage that will be required.
3. The total length of the turn lane and taper should accommodate storage requirements plus deceleration and taper. If this is not feasible, any of the following may be done to determine the length:
 - a. Include the transition length in the deceleration length.
 - b. Assume that vehicles slow down to 10 MPH below the roadway speed limit before entering the auxiliary lane and calculate deceleration needs based on this speed.
 - c. Calculate deceleration to a turning speed of 15 MPH rather than a full stop (more applicable to right turns).
 - d. If none of the above is feasible, the lanes should accommodate the 95th percentile queue length.
4. Turn lanes should be 11 feet wide; however, the lane width may be adjusted to be compatible with the adjacent roadway lane width. In no event shall the turn lane be less than 10 feet wide.

7-4(I)(7)(iii)(d) Right-turn Lane Design

The minimum storage and transition length requirements are provided in [TABLE 7.4.68](#), using [FIGURE 7.4.100](#) for right-turn lane design elements. The following assumptions are used to determine these requirements:

1. The minimum required lane length values assume the roadway has no more than 2% vertical grade. Longer deceleration lengths may be required on downgrades greater than 2%.
2. Required lane length assumes a 15 MPH speed differential.

FIGURE 7.4.100 Right-turn Lane Design Elements

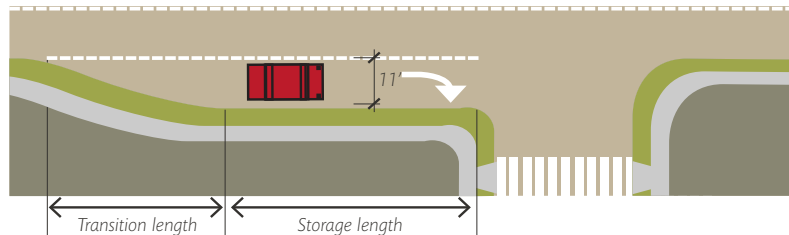

Design Speed of Roadway (MPH)	Minimum Storage Length (ft.)	Lane Transition Length (ft.)
<35	240	150-150 Reverse Curve
35 - 40	240 - 350	300-150 Reverse Curve
45 - 50	350 - 405	600-300 Reverse Curve

7-4(I)(7)(iii)(e) Right Taper Design

1. The use of tapers in lieu of dedicated right-turn lanes is strongly discouraged and requires approval of the City Engineer.
2. Minimum lane length and right-turn taper requirements are provided in [TABLE 7.4.69](#), using [FIGURE 7.4.101](#) for right taper design elements.

FIGURE 7.4.101 Right Taper Design Elements

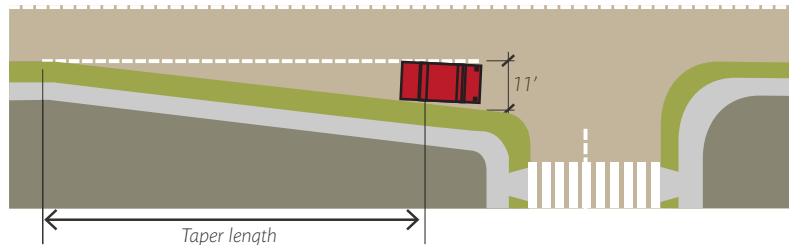

TABLE 7.4.69 Taper Design Criteria

Design Speed of Roadway (MPH)	Required Taper
30 - 40	8:1
45 - 50	15:1

7-4(I)(7)(iii)(f) Left-turn Lane Design

1. Where traffic is to be controlled by a traffic signal, the turn lane should be of sufficient length to store the turning vehicles and clear the equivalent lane volume of all other traffic on the approach, where feasible.
2. This length is necessary to ensure that full use of the turn lane will be achieved and that the queue of the other vehicles on the approach will not block vehicles from the turn lane.
3. The minimum left-turn lane transition length requirements are provided in [TABLE 7.4.70](#).

TABLE 7.4.70 Minimum Left-turn Lane Transition Length

Design Speed of Roadway (MPH)	Lane Transition (ft.)
<35	150 - 150 Reverse Curve
35 - 40	300 - 150 Reverse Curve
45 - 50	600 - 300 Reverse Curve

7-4(I)(7)(iv) Restricted Turning Movements

Restricted right and/or left turn movements may be required based upon factors such as one-way roadways or the necessary restriction of movements at a drive at the discretion of the City Engineer. (See [FIGURE 7.4.102](#) through [FIGURE 7.4.107](#) for illustrative examples of restricted turning movements.)

FIGURE 7.4.102 Right-in / Right-out

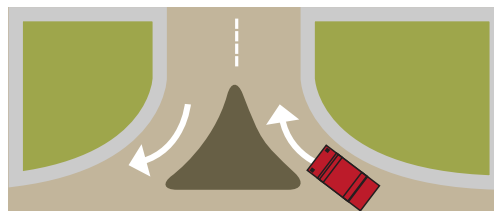

FIGURE 7.4.103 Right-in / Right-out and Left-in

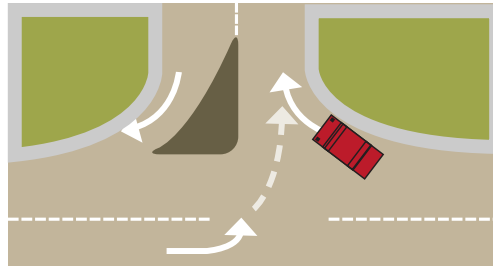

FIGURE 7.4.104 Right-in / Right-out and Left-out

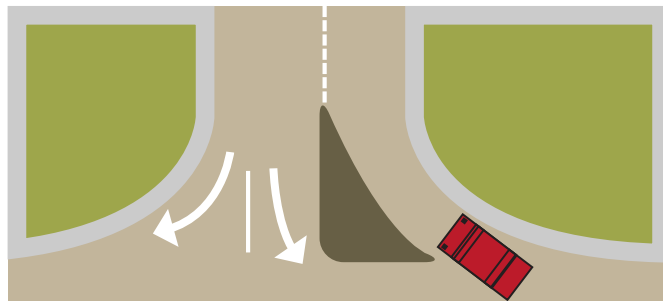

FIGURE 7.4.105 Restricted Median: Left-in Only

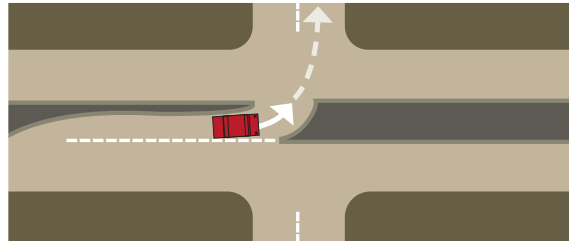

FIGURE 7.4.106 Restricted Median: Left-in and Left-out on One Side

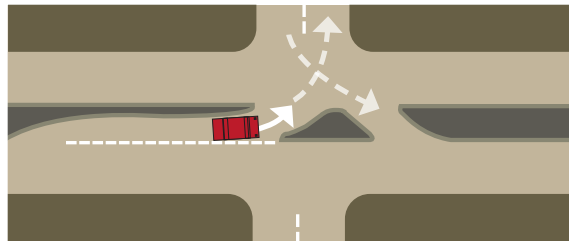
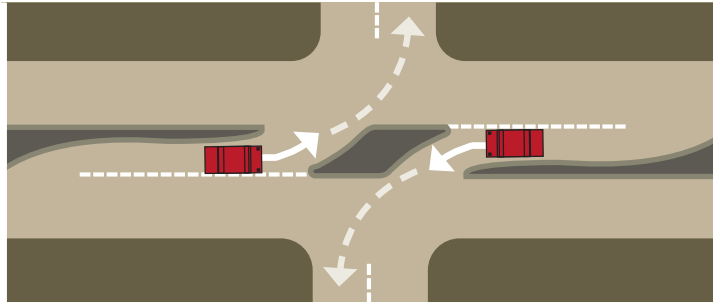

FIGURE 7.4.107 Restricted Median: Left-in Both Sides



7-4(I)(7)(v) Two-way Left-turn Lanes (TWLTL)

7-4(I)(7)(v)(a) Definitions and General Provisions

1. TWLTLs are continuous center lanes that allow motorists traveling in both directions to pull out of through lanes into a shared lane for left turns. TWLTLs offer spatial separation between opposing lanes of traffic and provide additional roadway capacity without adding general purpose lanes in each direction.

FIGURE 7.4.108 Two-way Left-turn Lane

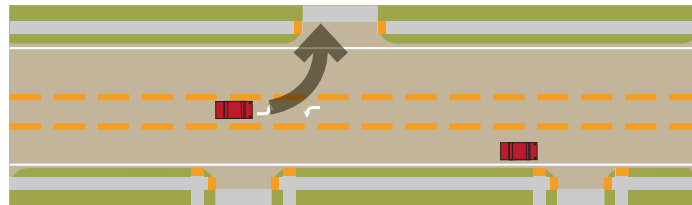

2. TWLTLs are recommended in locations with a high degree of land access, including a high intersection density and a large number of driveways, and where turning movements and business access on both sides of the street are desired.
3. TWLTLs are also appropriate where mid-block entrances are too close together to create dedicated turn lanes or turn bays.
4. Locations with few driveways or intersections are better served by medians and dedicated turn lanes.
5. TWLTLs are recommended in particular to preserve roadway capacity in the application of a road diet where a 4 or 6-lane roadway is converted to a 2 or 4 lane facility with a continuous center turn lane.
6. TWLTLs are not recommended in locations with traffic volumes above 30,000 ADT.

7-4(I)(7)(v)(b) Design Considerations

1. A TWLTL shall be 12-14 feet wide, measured from the middle of the striping on either side of the turn lane.
2. There should be no more than 2 through lanes in each direction adjacent to a TWLTL.
3. TWLTLs can create impediments for pedestrians as they add to crossing distance and may be incompatible with median refuge islands at mid-block crossings.

4. TWLTLs can lead to conflicting left-turn paths if driveways are poorly spaced and located. This situation may require raised medians in these areas to define left turn pockets and/or right-in right-out restrictions.

Part 7-4(J) Local Streets

This section provides guidance regarding the classification and design of local streets, private streets, stub streets, cul-de-sac, and single access to subdivisions. Local streets shall be designed to discourage high-speed driving and to support walking.

Section 7-4(J)(1) Local Street Classifications

There are 3 types of local streets, described below. The anticipated ADT for each type is provided in [TABLE 7.4.71](#).

1. **Access Local:** Loop streets, cul-de-sacs, and short segments that provide connections to other streets. Access locals are not continuous for more than 1 or 2 blocks.
2. **Normal Local:** Streets that direct traffic to major local streets or may connect directly to collectors or arterials.
3. **Major Local:** A street that conveys traffic from other local streets to collector or arterial streets. The intent of major local streets is to provide sufficient space for 2 vehicles to travel unimpeded in opposite directions at the same time.

TABLE 7.4.71 ADT Parameters for Local Streets

Street Type	ADT
Access Local	<250
Normal Local	250 - 1,000
Major Local	>1,000

FIGURE 7.4.109 Local Street Classification

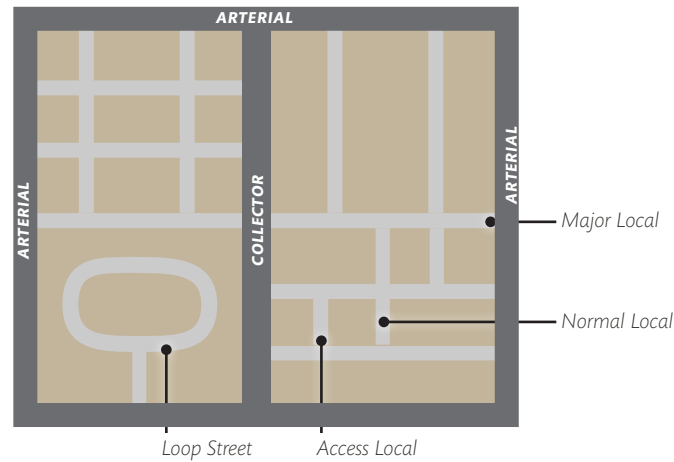

7-4(J)(1)(i) Trip Generation for Local Street Classification

A trip generation and distribution exhibit is required to classify new local streets. The traffic volumes shall be determined based on trip generation characteristics and the anticipated distribution of trips. The assumed ADT generated by different development types on local streets is provided in [TABLE 7.4.72](#). Additional information regarding trip generation and traffic studies is provided in [Article 7-5 Traffic Studies](#).

Type of Development	ADT per Unit
Single-family	10
Apartment/Townhouse	6
Non-residential or Mixed-use	Consult current ITE Trip Generation Manual

Section 7-4(J)(2) Local Street Design

7-4(J)(2)(i) Local Street Layout

1. Local street connectivity shall be consistent with standards in [Article 7-4 Design Standards](#) and the [LRTS Guide](#).
2. Block lengths shall be designed per [Part 7-4\(A\) Network Connectivity](#).
3. Block lengths of local streets in residential areas shall be no longer than 600 feet.

7-4(J)(2)(ii) Local Street Design Characteristics

1. Street design requirements for local streets are provided in [TABLE 7.4.73](#).
2. Pavement widths for streets adjacent to schools, within 150 feet of arterial or collector streets, and adjacent to large neighborhood parks should be designed to the larger end of the range of the "All Other Areas" categories.

3. Three (3) vehicle lanes may be provided as needed within 150 feet of intersections with collector or arterial streets, with 2 lanes for vehicles exiting and 1 lane for vehicles entering the Major Local street.
4. Right-of-way width requirements for extensions of existing roadways may be adjusted by the City Engineer if necessary to match existing right-of-way on the same street or to conform to drainage and/or landscaping requirements.
5. Bicycles may share the roadway on local streets. For additional information about bicycle lanes and bicycle routes, see [Part 7-4\(F\) Bikeways and Trails](#).
6. On-street parking is generally permitted on local streets, though on-street parking areas do not have to be designated (i.e. pavement markings, and signage), and additional right-of-way and pavement width are not required.
7. Bicycle lanes and designated on-street parking are discouraged on Access Local and Normal Local streets.
8. Additional road elements that may be added to the cross section for Major Local streets, depending on the context and location, include additional turning lanes, medians, bicycle lanes, designated on-street parking, and additional planting areas to accommodate large trees.
9. Intersections involving two local streets are generally served by stop or yield-sign controls or neighborhood traffic circles.
10. The following sections provide additional guidance on street element design:
 - a. [Part 7-4\(E\) Pedestrian Facilities](#) for guidance related to pedestrian facilities.
 - b. [Part 7-4\(F\) Bikeways and Trails](#) for bicycle facilities.
 - c. [Part 7-4\(H\) On-street Parking](#) for on-street parking.
 - d. [Section 7-4\(I\)\(6\)](#) for intersection design.
 - e. [Section 7-4\(I\)\(7\)](#) for medians and turn lane design.

TABLE 7.4.73 Local Street Design Standards

Corridor Type	Location	Design Speed (MPH)	Required Elements					Optional Elements	
			ROW Width (ft.)	Frontage Zone (ft.)	Sidewalk Width (ft.)	Landscape/ Buffer Zone (ft.)	Roadway Width (ft.) <small>(From curb face to curb face)</small>	Min. On-street Parking (ft.)	Min. Median (ft.)
Access Local	Citywide	15-25	44 - 46	0	5	4	26 - 28	N/A	N/A
Normal Local	Single-family Residential Areas	18-25	48 - 52	0	5	5	28 - 32	N/A	N/A
	All Other Areas	18-25	48 - 61	1-2.5	5	5	26 - 36	N/A	N/A
Major Local	Single-family Residential Areas	18-25	48 - 58	0	5	5	28 - 38	8	4 - 14
	All Other Areas	18-30	50 - 73	1-2.5	5	5-6	28 - 46	8	4 - 14

FIGURE 7.4.110 Typical Access Local and Normal Local Street Cross Section

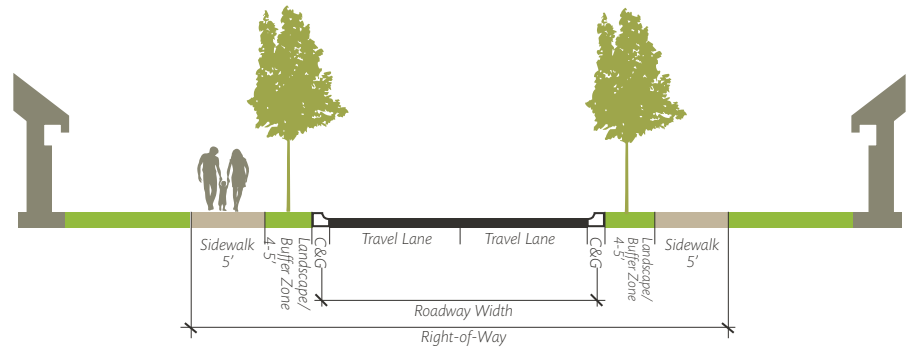

FIGURE 7.4.111 Major Local Street Cross Section with Designated Parking

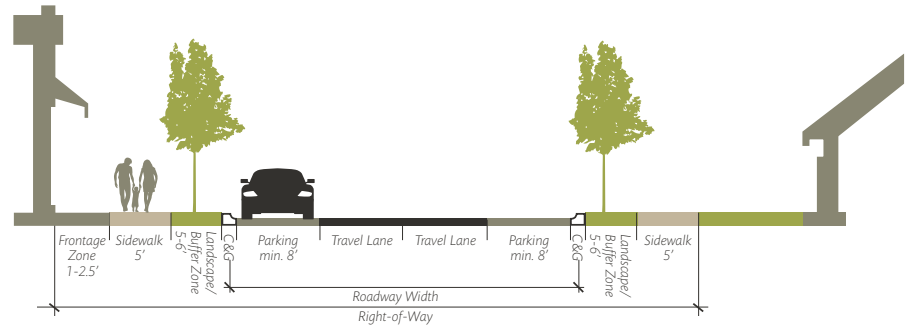
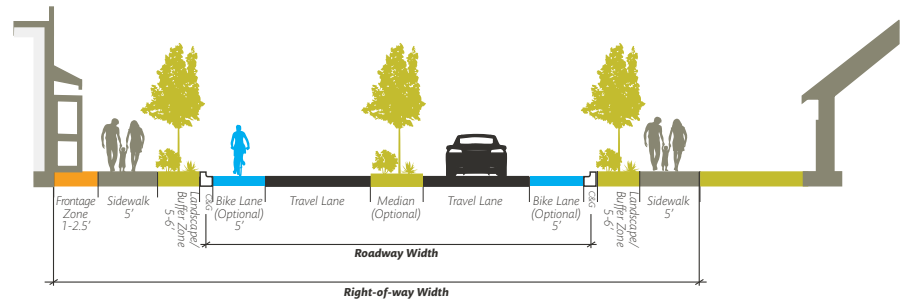

FIGURE 7.4.112 Major Local Street Cross Section with bicycle lanes



Section 7-4(J)(3) Stub, Cul-de-sac, and Loop Street Criteria

7-4(J)(3)(i) Stub Streets

1. Stub streets are the extension of a street past an intersection where a turnaround is not required. The length of a stub street is measured from the centerline of the intersecting street to the end of the stub street.
2. See additional requirements in [IDO Section 5-3\(E\)\(1\)\(d\) Stub Streets and Cul-de-sacs](#).
3. Stub streets shall follow design guidance for access local streets in [Section 7-4\(J\)\(2\) Local Street Design](#).

7-4(J)(3)(ii) Cul-de-sac and Hammerhead Streets

1. Cul-de-sac and hammerhead streets are short streets intersecting another street at one end and terminating at the other end with a vehicular turnaround. [FIGURE 7.4.113](#) and [FIGURE 7.4.114](#) show typical dimensions.
2. See [IDO Subsection 5-3\(E\)\(1\)\(d\) Stub Streets and Cul-de-sacs](#) and [Article 7-4 Design Standards](#) for appropriate locations and restrictions.
3. Cul-de-sacs and hammerhead streets shall follow design guidance for access local streets in [Section 7-4\(J\)\(2\) Local Street Design](#).
4. The maximum length permitted in a hammerhead or cul-de-sac street is as shown in [TABLE 7.4.74](#) and is measured from the centerline of the intersecting street to the center of the turnaround.

Min. F-F Street Width*	Max. Cul-de-sac Length
20 ft.	≤500 ft.
26 ft.	≤600 ft.

* Roadway width is measured from face of curb to face of curb.

FIGURE 7.4.113 Cul-de-sac Dimensions

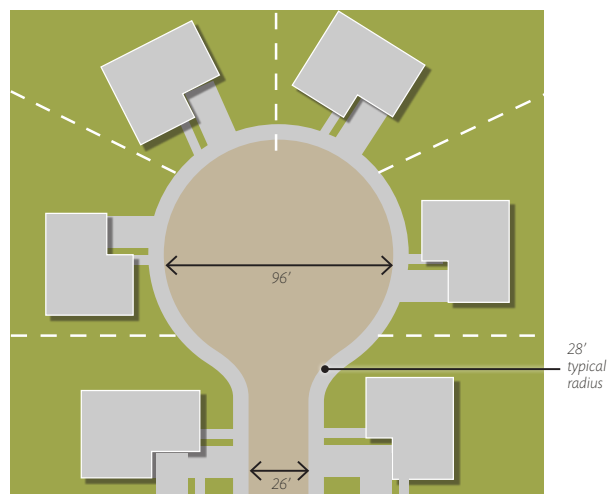
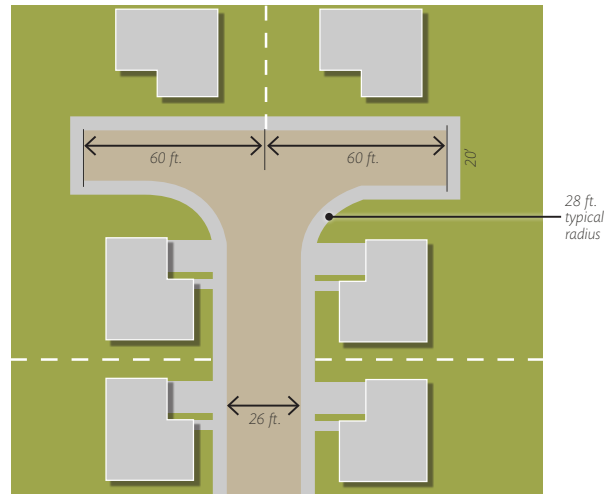

FIGURE 7.4.114 Hammerhead Dimensions



7-4(J)(3)(iii) Loop Streets

1. Loop streets shall have a maximum length of 1,320 feet, measured along a centerline, and shall be designated an access local street as described in [TABLE 7.4.73](#).
2. Loop streets shall be designed to prevent excessive speeds and have straight sections no longer than 600 feet.

Section 7-4(J)(4) Emergency Service Access to Local Streets

1. Fire access roads shall be designed per [Article 14-2 Fire Code \(ROA 1994\)](#).
2. A maximum of 30 dwelling units in a single- or two-family (i.e. duplex) residential subdivision may be served by a single point of access
3. A maximum of 100 dwelling units in a single- or two-family (i.e. duplex) residential subdivision may be served by a single point of access combined with a strategically located emergency access.
4. Single- or two-family residential subdivisions that contain over 100 units must provide 2 or more non-emergency access points.
5. An emergency access shall have all of the following:
 - a. Minimum 20 feet width with 28 foot radii at intersections with streets.
 - b. Improved low-maintenance surface (i.e. asphalt, concrete, or other approved driving surface capable of supporting 75,000 pounds).
 - c. Breakaway gate for closure during non-emergency times.

Section 7-4(J)(5) Private Streets

1. All private streets providing access to 8 or more dwelling units shall be built per [City Standard Specifications](#) and DPM requirements for local streets. Any deviation must be approved by the City Engineer.
2. The use of private streets in the design of exclusive access to lots is limited by the following requirements:
 - a. *The length, width, and permanent character of the private street must be suitably and legally defined by the plat establishing the lots being served. The lots served must abut or front the proposed private street.*
 - b. *The City Engineer shall determine that the proposed private street will always function as a street classified as a local street and designed per [Section 7-4\(J\)\(1\)](#) and that a City right-of-way would not better serve public purposes.*
 - c. *Easements for public utilities may be required.*
 - d. *Private streets shall be created by legal instrument that ensures future maintenance and operation as a private street.*

Section 7-4(J)(6) Private Ways

1. Private ways may be built for small subdivisions with 8 or fewer dwelling units.
2. Private ways shall be created by legal instrument that ensures future maintenance and operation as a private way. This may be done on a subdivision plat.
3. Private ways may be built per the DPM and [City Standard Specifications](#).
4. Private ways may be constructed of gravel or pavement.
5. The initial 25 feet behind the sidewalk on the intersecting street shall be paved, at a minimum, with 2 inches of asphalt on compacted subgrade as shown in the [City Standard Specifications](#).
6. The minimum design standards for private ways are provided in [TABLE 7.4.75](#).
7. The required access easement radii for a right angle turn in the easement as well as the connection to the public street is provided in [TABLE 7.4.76](#).

TABLE 7.4.75 Private Way Design Standards

Number of Dwelling Units with Direct Access	Min. Access Easement Width	Min. Road Improvements	Min. Pedestrian Improvements
1	15 ft.	15 ft.	N/A
2 - 3	22 ft.	22 ft.	N/A
4 - 8 (One Side Frontage)	29 ft.	24 ft.	1 5 ft. sidewalk
4 - 8 (Two Side Frontage)	34 ft.	24 ft.	2 5 ft sidewalks

TABLE 7.4.76 Easement Radii for Private Access Easements

Easement Width	Right Angle Turn within Easement	Connection to Public Street	Design Speed
15 ft. - 22 ft.	28 ft. Inside Edge Easement Radius	None	15 MPH
29 ft. - 34 ft.	50 ft. Centerline Radius	20 ft.	20 MPH

Section 7-4(J)(7) Entrance and Gate Requirements for Private Ways and Streets

1. All gated communities must include a turnaround for visitors at the gate so that the vehicle does not stand in or back into the City right-of-way.
2. Where a single gate is provided, the minimum width shall be 20 feet. For divided streets, the minimum width shall be 12 feet.
3. Additional entrance and gate requirements may be required by the Fire Marshal.

Part 7-4(K) Off-street Parking and Site Design

This section provides guidance on site design and off-street parking layout. The overall site design shall accommodate all modes of transportation including automobiles, pedestrians, bicyclists, and motorcyclists. To facilitate efficient parking operations, the designer shall also consider the interface of the site with adjacent development areas.

Section 7-4(K)(1) General Provisions

1. All sites and off-street parking areas shall be designed to comply with ADA/PROWAG standards.
2. The number of off-street, vehicle, bicycle and motorcycle parking spaces shall be provided as established in the [IDO Section 14-16-5-5 Parking and Loading](#).
3. Site design shall comply with design requirements and landscape buffers established by the [IDO Part 14-16-5 Dimensional Standards](#).
4. Parking and site layout shall be designed such that vehicles do not back into the City right-of-way, except single-family dwellings may back into local streets.

Section 7-4(K)(2) Bicycle Parking

Off-street bicycle parking location, layout and rack options vary widely. The following guidelines shall be considered when placing and designing bicycle parking areas and choosing rack options. Alternative rack design, placement, or installation methods not meeting the guidelines below may be considered and are reviewed on a case-by-case basis by the City Engineer.

1. All bicycle racks shall be designed according to the following guidelines:
 - a. The rack shall be a minimum of 30 inches tall and 18 inches wide.
 - b. The bicycle frame shall be supported horizontally at two or more places. Comb/toaster racks are not allowed.
 - c. The rack shall be designed to support the bicycle in an upright position. See the [IDO Section 14-16-5-5\(E\)](#) for additional information.
 - d. The rack allows varying bicycle frame sizes and styles to be attached.
 - e. The user is not required to lift the bicycle onto the bicycle rack.
 - f. Each bicycle parking space is accessible without moving another bicycle.
2. Bicycle parking spaces shall be located in a well-lit area, visible from and, where feasible, located within 50 feet of the primary pedestrian entrance it serves. Bicycle rack placement shall meet the following placement requirements. (See [FIGURE 7.4.115](#) for direction on bicycle stall layout.)

- a. Bicycle parking shall be separated from vehicle parking areas and driveways by a barrier, such as a curb, rail, or bollard, or be located to minimize the possibility of vehicles striking parked bicycles.
 - b. Bicycle racks shall be placed in a designated area and shall not infringe upon the width of the required clear pedestrian access route. (See [Part 7-4\(E\) Pedestrian Facilities](#).)
 - c. Bicycle racks shall not be placed directly in front of entrances or in locations that impede pedestrian flow.
3. Bicycle racks shall be sturdy and anchored to a concrete pad.
 4. A 1-foot clear zone around the bicycle parking stall shall be provided.
 5. Bicycle parking spaces shall be at least 6 feet long and 2 feet wide.

FIGURE 7.4.115 Bicycle Parking Stall Layout Options

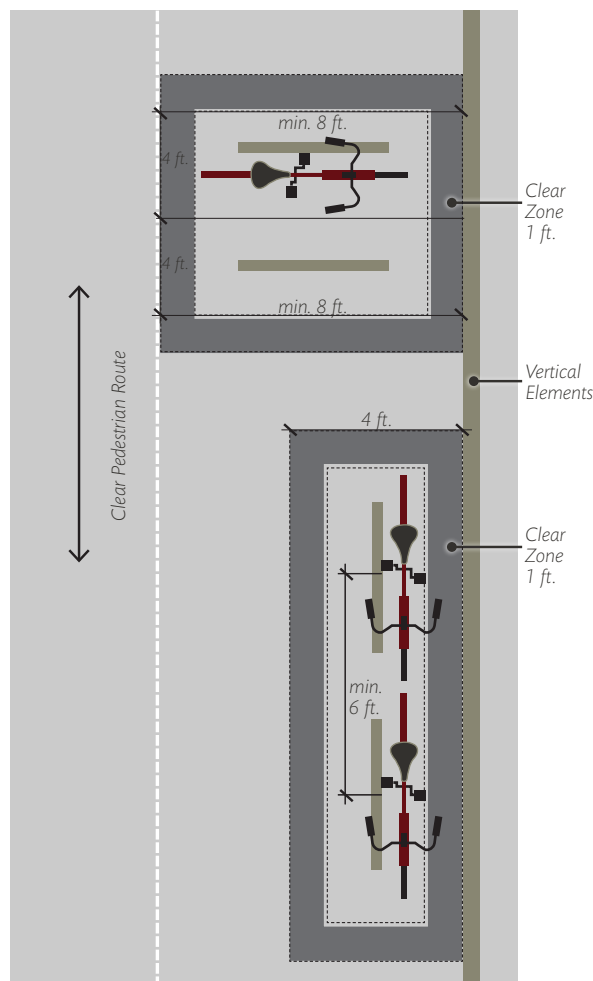

Section 7-4(K)(3) Motorcycle Parking

1. Motorcycle parking shall be a minimum of 4 feet wide and 8 feet long. (See [TABLE 7.4.77](#) and [FIGURE 7.4.116](#).)
2. Motorcycle parking spaces shall be located in a well-lit area that is visible from the primary building entrance on the site.

- Motorcycle spaces shall be designated with a posted upright sign, either free standing or wall mounted. Each sign shall be no smaller than 12 inches by 18 inches and shall have its lower edge no less than 4 feet above grade.

Section 7-4(K)(4) Standard and Small Car Parking

- Minimum parking stall dimensions are provided in [TABLE 7.4.77](#) and [FIGURE 7.4.116](#).
- If the premises contains more than 20 spaces, ¼ of the spaces may be compact parking spaces for small cars with dimensions per [TABLE 7.4.77](#).
- Compact parking spaces shall be identified by the word “Compact” on the pavement of each space.
- Vehicles may overhang walkways and landscape areas as long as the overhang does not negatively impact the proposed landscape or reduce the required pedestrian access route to less than 4 feet wide.
- The maximum overhang of parking spaces are 2 feet for standard parking spaces and 1.5 feet for small car spaces.
- Vehicles shall not overhang City right-of-way or access ramps.
- Parking spaces shall not cross over lot lines.
- All parking spaces must be clearly identified through use of parking blocks, stripes, or other acceptable means.

TABLE 7.4.77 Parking Stall Dimensions			
Type of Parking	Min. Width	Min. Length	Max. Overhang*
Standard	8.5 ft.	18 ft.	2 ft.
Small Car/Compact	7.5 ft.	15 ft.	1.5 ft.
Motorcycle	4 ft.	8 ft.	N/A
ADA Accessible	8.5 ft.	18 ft.	2 ft.

* Overhang not acceptable at ADA ramps.

FIGURE 7.4.116 Parking Stall Dimensions

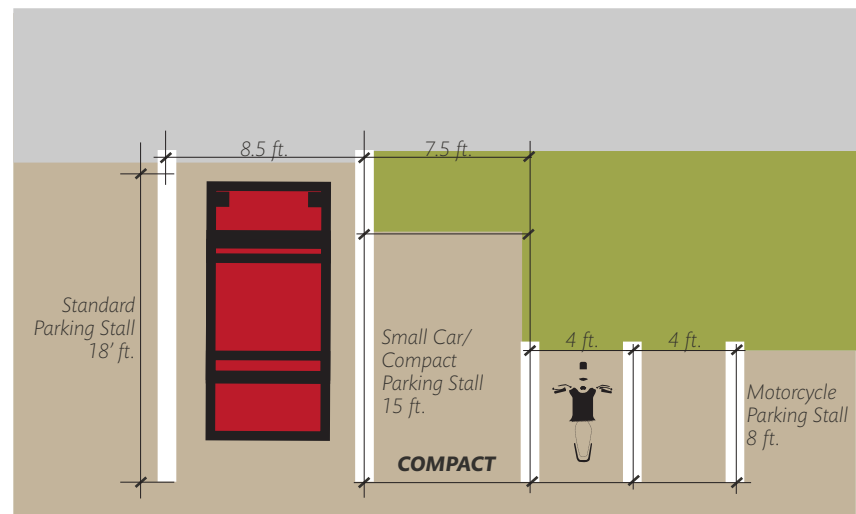

Section 7-4(K)(5) ADA Accessible Parking

1. ADA accessible parking shall be a minimum of 8.5 feet wide and 18 feet long. (See [TABLE 7.4.77](#) and [FIGURE 7.4.117](#))
2. Accessible parking spaces shall be located closest to the building entrances and dispersed among the various types of parking facilities and uses.
3. All accessible parking spaces shall include an access aisle.
4. Van access aisles shall be a minimum 8 feet wide; all others shall be a minimum 5 feet wide.
5. Access aisles shall not overlap the vehicular way.
6. Two (2) parking spaces may share a common access aisle.
7. Each access aisle must adjoin a pedestrian access route.
8. Angled van parking spaces shall have access aisles located on the passenger side of the parking spaces.
9. The accessible route cannot be located at the rear of the parking stall or adjacent to a vehicle route.
10. Access aisles shall have blue diagonal striping and the words "NO PARKING" in capital letters, each of which shall be at least 1 foot high and at least 2 inches wide, placed at the rear of the parking space so as to be close to where an adjacent vehicle's rear tires would be placed.
11. Accessible parking spaces shall have a clearly visible, blue, International Symbol of Accessibility painted on the pavement within the rear of the space.
12. A 12 inch by 18 inch sign with the International Symbol of Accessibility shall be provided at the head of each ADA accessible parking space. The sign must have the required language per [66-7-352.4C NMSA 1978](#): "Violators Are Subject to a Fine and/or Towing."
13. Where the total number of parking spaces provided is 4 or fewer, the International Symbol of Accessibility pavement marking is not required in the required accessible parking space.

FIGURE 7.4.117 ADA Accessible Parking Stall and Access Aisle Dimensions



Section 7-4(K)(6) Angled Parking

1. Angled parking stalls should accommodate a minimum 8.5' wide and 18' long vehicle space. (See [FIGURE 7.4.118](#) and [TABLE 7.4.78](#) and for additional information on layout options and dimensions.)
2. Parking barriers and/or extended shy zones are recommended to ensure that vehicles with long rear overhangs do not intrude into the required clear pedestrian access route.

FIGURE 7.4.118 Dimensions for Angle Parking

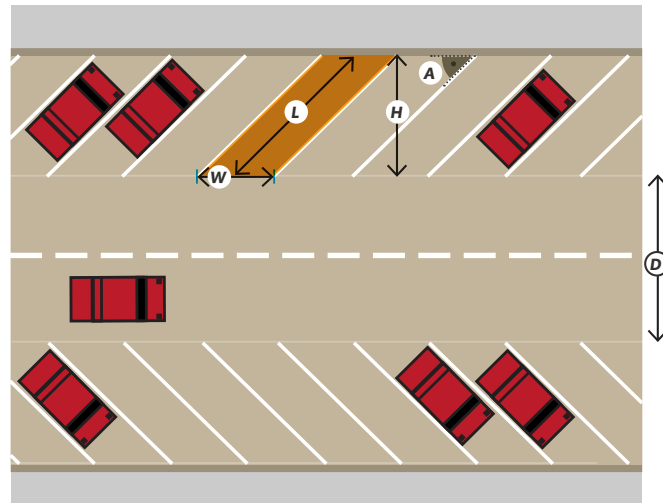

TABLE 7.4.78 Dimensions for Standard Angle Parking

Angle (A)	Stall Length (L)	Stall Width (W)	Stall Depth (H)	Drive Aisle (D)
30°	32.7 ft.	17 ft.	16.4 ft.	11 ft.
45°	26.5 ft.	12 ft.	18.7 ft.	11 ft.
60°	22.9 ft.	9.8 ft.	19.8 ft.	15 ft.
75°	20.3 ft.	8.8 ft.	19.6 ft.	22 ft.
90°	18 ft.	8.5 ft.	18 ft.	24 ft.

TABLE 7.4.79 Dimensions for Compact Angle Parking

Angle (A)	Stall Length (L)	Stall Width (W)	Stall Depth (H)	Drive Aisle (D)
30°	28 ft.	15 ft.	14 ft.	11 ft.
45°	22.5 ft.	10.6 ft.	15.9 ft.	11 ft.
60°	19.3 ft.	8.7 ft.	16.7 ft.	15 ft.
75°	17 ft.	7.8 ft.	16.4 ft.	22 ft.
90°	15 ft.	7.5 ft.	15 ft.	24 ft.

Section 7-4(K)(7) Off-street Loading Spaces

7-4(K)(7)(i) Dimensions of Off-street Loading Spaces

If off-street loading spaces are required by [IDO Subsection 5-5\(H\)\(1\)](#), the required dimensions of those spaces are provided in [TABLE 7.4.80](#).

TABLE 7.4.80 Off-street Loading Space Dimensions			
Zone District (per IDO)		Min. Width	Min. Length
Non-residential	First required space	12 ft.	65 ft.
	Additional spaces	10 ft.	25 ft.
Residential / Mixed-use	All spaces	9 ft.	25 ft.

7-4(K)(7)(ii) Design and Layout of Off-street Loading Areas

Off street loading areas shall comply with all of the following standards:

1. Trucks using the loading area shall not be required to back into a public street to leave the site.
2. Truck and loading operations shall not encroach into any pedestrian walkway, bicycle lane, City right-of-way, fire lane, or required setback.
3. Loading spaces shall not be located in a required front or side setback abutting any City right-of-way and, to the maximum extent feasible, shall be located to the rear of a site and away from adjacent residential areas.
4. For a site adjoining an alley that does not abut any Residential zone district, required loading spaces shall be accessed from the alley.
5. The design and layout shall comply with all applicable provisions in [IDO Subsection 5-5\(H\)](#).

Section 7-4(K)(8) Pavement of Parking Areas

Parking areas shall be paved per the following standards:

1. Pavement shall be maintained level and serviceable.
2. Where a site has 4 or more off-street parking spaces that require access off of an alley, the full width of the alley shall be paved from the parking access drive to a street, per the [City Standard Specifications](#).
3. Designated ADA accessible parking spaces and pedestrian pathways must be paved with a minimum 2 inch asphalt pavement over a 4 inch compacted subgrade or equivalent per City standards to ensure compliance with federal guidelines.
4. Additional requirements and information of acceptable pavement materials are provided in [Part 7-4\(C\) Pavement Design](#).

Section 7-4(K)(9) Curbing in Parking Areas

1. Curbing should be installed to delineate landscape, parking, and pedestrian ways and identify points of access.
2. Parking areas shall have barriers to prevent vehicles from extending over public sidewalk, City right-of-way, or abutting lots.
3. Additional requirements are provided in [Part 7-4\(D\) Curb and Gutter](#).

Section 7-4(K)(10) Grading in Parking Areas

1. The maximum grades in parking areas should not exceed 8%.

2. For major circulation aisles and adjacent to major pedestrian entrances, the grade shall be 5% or less.
3. ADA accessible parking spaces, access aisles, and access routes shall not exceed 2% in any direction.
4. Curb ramps shall not extend into any ADA accessible parking access aisle.

Section 7-4(K)(11) Sidewalk Connections

A separate pedestrian access route, referred to as a private walkway, shall be included connecting the public sidewalk to the buildings within the development. Additional requirements are provided in [Part 7-4\(E\) Pedestrian Facilities](#) and [IDO Subsection 5-3\(D\)\(3\) On-site Pedestrian Connections](#).

Section 7-4(K)(12) Site Access

Parking lot access shall be designed to reduce conflicts with pedestrians and vehicular traffic and allow efficient ingress and egress of a parking area. Additional site access requirements are provided in [Part 7-4\(B\) Site Access Points](#).

1. Adequate turning radii and queuing areas shall be maintained to provide continuous flow of traffic.
2. The design of the site access point should not impede pedestrian circulation and should facilitate efficient movement of pedestrians across the site access area.
3. Landscaped islands at the site access point may be provided to create a buffer and allow an adequate turning area.
4. At the site access point, a 15-foot radius should be used where only cars are to be accommodated.

FIGURE 7.4.119 Site Access Design

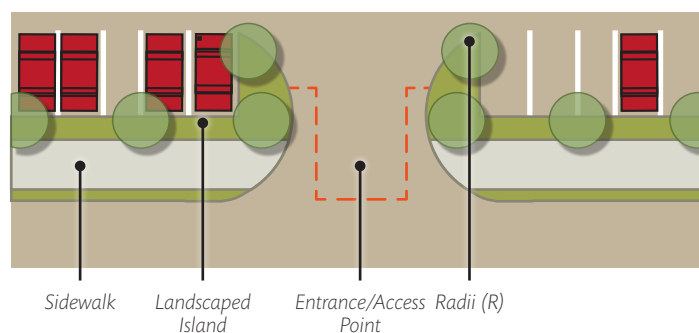

Section 7-4(K)(13) Fire and Emergency Access

Fire and emergency vehicle access shall be provided per [Article 14-2 Fire Code \(ROA 1994\)](#).

Section 7-4(K)(14) Solid Waste Access

Refuse vehicle maneuvering shall be contained on site. The refuse vehicle shall not back into the City right-of-way.

Section 7-4(K)(15) Access Throat Length and Queuing

1. For all new development projects, queuing needs and the number of lanes for site access shall be evaluated.
2. The location of any access aisle shall preserve the queuing area for peak traffic generation periods.
3. [TABLE 7.4.81](#) shall be used to determine the access point throat lengths necessary to make adequate provisions for queuing.
4. For those land uses that are not represented, comparable lengths should be established based on traffic generation characteristics contained in the [ITE Trip Generation Manual](#).

FIGURE 7.4.120 Throat Length

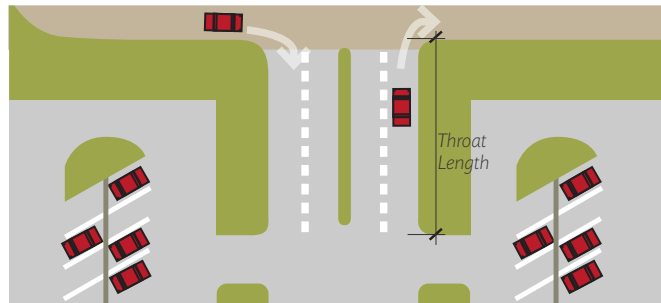

TABLE 7.4.81 Minimum Throat Length

Land Use	Size of development	Collector	Arterial
Light & Heavy Industrial	<100,000 sq. ft.	25 ft.	50 ft.
	100,000 - 500,000 sq. ft.	50 ft.	100 ft.
	>500,000 sq. ft.	100 ft.	150 ft.
Commercial Development	<50,000 sq. ft.	25 ft.	50 ft.
	50,000 - 100,000 sq. ft.	50 ft.	75 ft.
	100,000 - 200,000 sq. ft.	75 ft.	100 ft.
	>200,000 sq. ft.	100 ft.	125 ft.
Multi-family Development	<100 dwelling units	25 ft.	50 ft.
	100-200 dwelling units	50 ft.	75 ft.
	>200 dwelling units.	75 ft.	100 ft.

Section 7-4(K)(16) Site Layout and Circulation

1. Parking areas must provide internal circulation with a logical pattern that the driver can easily understand and follow.
2. The parking lot area should allow efficient movement of vehicles, bicyclists, and pedestrians.
3. Circulation shall be designed to avoid conflicts between vehicular, bicycle, and pedestrian traffic.
4. The parking layout should provide continuous flow of traffic through the lot.

5. Where a large number of compact parking spaces are provided, these spaces should be spread throughout the parking area instead of being clustered in one area.
6. A 5 foot keyway is required for dead-end parking aisles. (See [FIGURE 7.4.121](#)).
7. The minimum drive aisle dimensions are shown in [TABLE 7.4.82](#).
8. See additional requirements in [IDO Subsection 5-5\(F\) Parking Location and Design](#).

FIGURE 7.4.121 Keyway in Parking Area

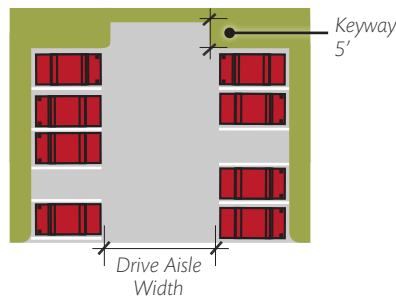

TABLE 7.4.82 Minimum Drive Aisle Width

Drive Type	Min. Drive Aisle Width
Two Way Traffic	22 ft.
Main Circulation Road	24 ft.
Fire Lane*	20 ft.

* The Fire Marshal may require additional width adjacent to tall buildings.

Section 7-4(K)(17) Parking Islands

1. In parking areas of 50 spaces or more, the ends of parking aisles shall be defined by parking islands. These islands define the parking stalls and provide adequate radii for vehicle turns and visibility.
2. Where the design vehicle is a passenger car, the radius should be 15 feet. (See [FIGURE 7.4.122](#).)
3. Where the aisles will function for deliveries by larger trucks, refuse, and/or fire vehicles, a 25-foot radius or larger should be used.

FIGURE 7.4.122 Parking Islands

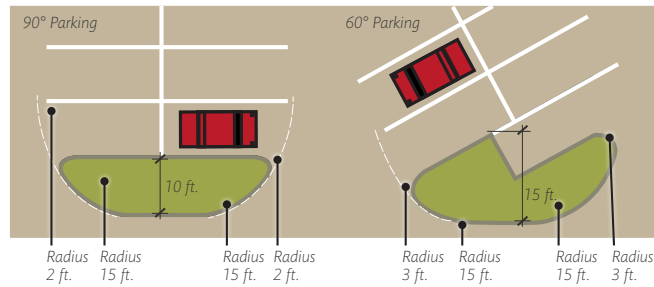

Section 7-4(K)(18) Service Areas

1. Service areas and service vehicle circulation requirements shall be accommodated in the site layout.
2. Site layout shall consider the circulation, backing, and storage requirements of the expected design vehicle.
3. Truck ramps, refuse/compactors, and similar facilities should be separated from the circulation aisles.
4. Visibility for parking and drive aisles shall be maintained in service areas.
5. Service vehicles shall not back into or from the City right-of-way

Section 7-4(K)(19) Signage & Striping

1. Adequate signing and striping shall be incorporated into the design of the parking area to convey to the motorist the proper use of the facility.
2. All one-way drives shall have "ONE WAY" and "DO NOT ENTER" signage and pavement markings.

Section 7-4(K)(20) Drive-through Facilities

1. Drive-through facilities shall be designed in accordance with requirements established by the [IDO Subsection 14-16-5-5\(l\)](#).
2. Drive-through queuing characteristics shall be accommodated in the site design.
3. Queuing of drive-through facilities should not interfere with either the access to the site, parking and circulation aisles, or the City right-of-way.
4. Each stacking space in the queuing lane shall be 20 feet long.
5. Queuing lanes shall be a minimum of 12 feet wide with a 25 foot minimum radius (inside edge) for all turns. A 15 foot radius may be used with an increase in lane width to 14 feet.
6. Uses not specified in [IDO Subsection 14-16-5-5\(l\)](#) shall feature the queue lengths associated with a similar use, as approved by the City Engineer.

Section 7-4(K)(21) Layout of Large Parking Areas

1. In large developments with more than 400 parking spaces a 24 foot wide circulation roadway shall be established to accommodate two-way traffic and emergency vehicles, and to facilitate loading and unloading activities.
2. No parked vehicles shall back into the circulation roadway.
3. The maximum drive aisle length is 400 feet, with 300 feet recommended, to discourage excessive vehicular speeds. Design that introduces curves

and/or breaks in the parking lot pattern should be used to help control speeds.

Section 7-4(K)(22) Traffic Circulation Layout (TCL)

1. The TCL site plans are required for commercial and institutional buildings, multi-family residential buildings, and commercial additions of 500 square feet or more. Information about TCL submittal requirements can be obtained from the City website.
2. The TCL must be stamped, signed, and dated by an engineer or architect licensed in the state of New Mexico.

Part 7-4(L) Traffic Calming

Section 7-4(L)(1) Neighborhood Traffic Calming

The Department of Municipal Development operates the City of Albuquerque [Neighborhood Traffic Management Program \(NMTP\)](#). The purpose of the program is to address speeding and cut-through traffic on local residential streets using a set of traffic-calming tools. These include physical tools, such as lane narrowing, turn restrictions, curb bulb-outs, and speed dips, as well as non-physical tools like radar speed signs and targeted enforcement. Further information about available strategies can be found in the Traffic Calming Toolkit.

The application process, warrants, and the procedure for implementing traffic calming requests can be found in the [NTMP Policy Manual](#).

Some traffic calming tools (e.g. speed humps, bulb-outs, lane narrowing, etc.) will reduce the hydraulic capacity of streets and may cause flows to exceed curb height. A hydraulic analysis of street flows may be required by the City Hydrologist prior to construction.

Section 7-4(L)(2) Speed Management on Major Roads

Traffic calming, or speed management techniques, may be considered on collector and arterial roadways depending on the location, the desired function of the roadway, roadway geometry including considerations such as sight distance, and/or observed traffic characteristics. Speed management on major roads should be implemented in a targeted manner since collectors and arterials also play a role in regional mobility and must balance the needs of all users. Any improvements shall consider LOS as well as [ABC Comp Plan](#) Table 7-5: Priority Street Element Matrix and are subject to approval by the City Engineer.

7-4(L)(2)(i) Definition

Speed management involves elements along a roadway that physically narrow the road and improve visual awareness among motorists. These techniques are intended to discourage high speed travel in locations with high levels of pedestrian activity. Beyond reduced speed and improved safety, benefits include additional space in the pedestrian realm for utilities, street furniture, and other amenities.

7-4(L)(2)(ii) Appropriate Locations

Though some speed management techniques, such as signal coordination and lane width reductions, can be introduced in most contexts, the introduction of certain speed management techniques depends on the location and context. In general, speed management techniques may be introduced in the following situations:

1. Within Centers
2. Near pedestrian generators, such as schools and retail centers
3. Along bicycle routes and bicycle boulevards
4. Along other Major Transit, Multi-modal, and Main Street Corridors as appropriate

7-4(L)(2)(iii) Speed Management Toolkit

Provided below are general speed management techniques that may be appropriate along collector and arterial roadways. Speed management measures are most effective when used in combination, and must be accompanied by appropriate signage.

1. **Intersection geometry improvements:** Physical changes that narrow a roadway to encourage slower vehicle speeds and reduce the crossing distance for cyclists and pedestrians. Examples include curb extensions and median refuge islands. See the [NACTO Urban Street Design Guide](#) for curb extension concepts.
2. **Median refuge islands:** Technique used to narrow roads, provide visual prompts to motorists, and allow for shorter pedestrian crossings. See the Pedestrian Facilities section for guidance on median refuge islands and the application of curb extensions at intersections.
3. **Road diets:** A range of techniques to encourage slower travel speeds and create space for other users. Concepts are divided into two categories:
 - a. **Road reconfiguration:** *Redesign of roadways to produce narrower and fewer travel lanes and increase the space within the right-of-way allocated for bicyclists and/or pedestrians. Redesigns may include other features to reduce travel speeds, including on-street parking, signage, and street trees or landscaping. Road reconfigurations may be achieved through restriping and reallocation of roadway space or as part of a reconstruction project.*
 - b. **Restriping and narrowing of travel lanes:** *Approach that maintains the same number of travel lanes, but narrows general purpose lanes to create space to add or widen bicycle lanes, insert marked buffers, and/or widen sidewalks. Travel lanes and protected turn lanes may be reduced to 10-11 feet.*
4. **Traffic signal timing:** Technique that sets signals for a target speed and requires moderate travel speeds for drivers to hit each traffic light in succession.
5. **Signage and radar speed signs:** Use of signage and technology to improve awareness and provide motorists feedback on their travel speeds.
6. **Roundabouts:** Intersection design in which all movements are one-way. Roundabouts can reduce crash severity while decreasing overall delay. See section [7-4\(l\)\(6\)\(i\) Intersection Traffic Control Typologies](#) for information on traffic circles and roundabouts.
7. **Vertical elements:** Design elements that cause motorists to slow down through deflection techniques such chicanes as road narrowing medians, or vertical speed control elements such as speed humps, speed cushions, and speed tables (which may be applicable to streets outside of neighborhood contexts).

Part 7-4(M) Street Lighting

Section 7-4(M)(1) Roadway Lighting Criteria

7-4(M)(1)(i) Definition of Terms

1. **Average Maintained Illuminance:** The output of the lamp and luminaire, after being reduced by maintenance factors (e.g. light loss depreciation and dirt depreciation), expressed in average-foot-candles (ft-cd or lux) for the pavement area.
2. **Correlated Color Temperature (CCT):** A characteristic of visible light describing the color a light emits comparable to that of the light source.
3. **IESNA RP-8:** Illuminating Engineering Society of North America (IESNA) provides recommended roadway design criteria in its document called [Recommended Practice 8, Roadway Lighting \(IESNA RP-8\)](#)
4. **Light Emitting Diode (LED):** A light source shown to have lower energy consumption and longer lifetime than incandescent light sources.
5. **Light Loss Depreciation:** The decline in the light lumen that occurs as a lamp is operated over time.
6. **LM-80-08:** IESNA Approved Method for Measuring Lumen Maintenance of LED Light Sources
7. **Luminaire Dirt Depreciation:** The process of dirt accumulating on luminaires, decreasing the total output of light and lowering the overall efficiency of the system

7-4(M)(1)(ii) General Provisions

1. The City of Albuquerque adheres to [IESNA RP-8](#) guidelines for roadway illuminance, uniformity ratios, and veiling luminance ratios. Also see [IDO Section 14-16-5-8 Outdoor Lighting](#) for more guidelines.
2. Low-power LED lights shall be installed on all streets.
3. All streets shall be illuminated to IESNA standards. Street lights shall be located at all intersections, on cul-de-sac streets over 200 feet in length, at right angle turns, and at mid-block locations where block lengths exceed 500 feet.
4. Street light electrical infrastructure wiring shall be aluminum with the standard aluminum label permanently affixed to the exterior of the street light pole above the electrical service hand-hole.
5. All street light poles shall be steel, aluminum, or other City approved and UL listed materials.
6. New wood and fiberglass poles are prohibited to be used for City assets.
7. [TABLE 7.4.83](#) shows the minimum average illuminance to be maintained in the City of Albuquerque.

TABLE 7.4.83 Minimum Average Maintained Illuminance. E_h

Pavement Classification	R1	R2 or R3	R4
E_h (ft-cd)	1.4	2.0	1.8

R1 = Portland cement concrete
 R2 = asphalt, aggregate consists of minimum 60% gravel passing 3/8-in sieve
 R3 = asphalt, rough texture (typical highway)
 R4 = asphalt, smooth texture

TABLE 7.4.84 Minimum Average Maintained Illuminance

Pavement Classification	E_h (ft-cd)
Portland cement concrete	1.4
Asphalt (aggregate minimum 60% gravel passing 3/8 in. sieve) asphalt (rough texture-typical highway)	2.0
Asphalt (smooth texture)	1.8

8. The City recommended ranges for the average maintained illuminance levels for various roadway classifications is provided in [TABLE 7.4.85](#). The table is derived for all types of road surface classification.

TABLE 7.4.85 Illuminance Method - Recommended Values

Roadway & Pedestrian Conflict Area		Pavement Classification (Minimum Maintained Average Values)			Uniformity Ratio	Veiling Luminance Ratio
Road	Conflict Area	R1 lux/ftc	R2 & R3 lux/ftc	R4 lux/ftc	E_{avg} / E_{min}	$L_{v,max} / L_{avg}$
Commuter Corridor	High	12.0/1.2	17.0/1.7	15.0/1.5	3.0	0.3
	Medium	9.0 / 0.9	13.0/1.3	11.0/1.1	3.0	0.3
	Low	6.0 / 0.6	9.0 / 0.9	8.0 / 0.8	3.0	0.3
Major Transit	High	8.0 / 0.8	12.0/1.2	10.0/1.0	4.0	0.4
	Medium	6.0 / 0.6	9.0 / 0.9	8.0 / 0.8	4.0	0.4
	Low	4.0 / 0.4	6.0 / 0.6	5.0 / 0.5	4.0	0.4
Local	High	6.0 / 0.6	9.0 / 0.9	8.0 / 0.8	6.0	0.4
	Medium	5.0 / 0.5	7.0 / 0.7	6.0 / 0.6	6.0	0.4
	Low	3.0 / 0.3	4.0 / 0.4	4.0 / 0.4	6.0	0.4

9. These illuminance guidelines are subject to the spacing to mounting height ratio.
10. The target spacing to mounting height (S/MH) ratio for highway, arterial, and collector streets is 3:5.
11. For local streets and alleys, pole heights and spacing will often be insufficient to achieve IESNA recommended illuminance levels without violating uniformity and veiling recommendations. The intent of these pole locations is to alert drivers to upcoming intersections and provide a source of orientation.

Section 7-4(M)(2) New Lighting System Considerations

1. Pole configurations and luminaires should be selected to distribute light in accordance with ANSI/IESNA standards for the most current [Recommended Practice for Design and Maintenance of Roadway and Parking Facility Lighting](#). See also the U.S. Department of Energy (DOE) [Model Specification for LED Roadway Luminaires](#).
2. Luminaire mounting height (MH) should vary in proportion with road width (RW).
 - a. As a default, the RW/MH ratio may vary between 1.0 and 2.75. In these scenarios, with a unilateral pole configuration, the S/MH ratio must be ≤ 5 .
 - b. Higher RW/MH Ratios will need shorter S/MH Ratios, between 3 and 5. Different solutions are possible depending on luminaire photometric distribution types, arm lengths, over hang, and luminaire tilt.
 - c. Software calculations using IESNA files, lighting depreciation factors (LLF) to verify maintained lighting levels, and appropriate roadway reflectance values for luminance may be required for verification.

Section 7-4(M)(3) Distribution Criteria

7-4(M)(3)(i) Vertical Light Distribution

1. For residential areas, mixed-use and commercial areas, all luminaires must have a full cutoff luminaire light distribution with zero candelas (intensity) at an angle of 90 degrees or above, or a Cutoff luminaire light distribution where the candela per 1,000 lumens does not exceed 25 (2.5%) at an angle of 90 degrees or above.
2. By establishing the standards for lighting fixtures in residential, intermediate, and commercial areas, rear obtrusive light can be minimized.

7-4(M)(3)(ii) Lateral Light Distribution

1. LED luminaire manufacturers generally offer light distributions based on National Electrical Manufacturers Association (NEMA) distribution types ranging from Type I to Type VII.
2. Roadway luminaires typically fall between Type II and Type V.
3. The selected optic type will depend on the specific configuration that the luminaire is deployed in.
4. Relevant variables include road width, pole spacing, and mounting height.
5. Light distributions for the same optic type may also vary from manufacturer to manufacturer.

Section 7-4(M)(4) Correlated Color Temperature (CCT)

1. A hierarchy of CCTs corresponding to roadway type and usage may provide benefits to citizens and tourists alike through improved wayfinding and ambience.
2. In general, lower traffic areas such as residential neighborhoods should receive warmer white (lower kelvin) luminaires, whereas higher traffic areas (major roads, highways) should receive cooler white (higher kelvin) luminaires.
3. Exceptions may be made for specific locations, such as Historic Old Town or Hunning Highland.

4. Lower color temperatures should be given preference in order to comply with American Medical Association (AMA) and International Dark-Sky Association (IDA) recommendations.
5. CCTs above 4000K shall be avoided.
6. The CCT hierarchies listed below shall be deployed for similar visual perception goals:

Local / Residential Street	Collector Street / Major Transit Corridor	Commuter Corridor
3000K	3500K	4000K

7. LED technologies and CCT availabilities and efficacies are routinely evolving. These standards should be revised in accordance with industry best practice.

Section 7-4(M)(5) Luminaire Criteria

Luminaires shall satisfy all system design criteria listed above. In addition, all luminaires should meet or exceed the following luminaire level criteria.

7-4(M)(5)(i) Performance Criteria

1. Efficacy (lumens/Watt): > 90 lm/W
2. Color Rendering Index (CRI): > 65
3. Lumen Maintenance (L70): L70 > 50,000 hours as supported by LM-80 and TM-21 documentation.
4. CCT: As specified in [ANSI C78.377](#)

NOTE: Adapted from [ANSI C78.377](#).

Manufacture Rated Nominal CCT (K)	Allowable IESNA LM-79 Chromaticity Values	
	Measured CCT (K)	Measured Duv
3000	2870 to 3220	-0.006 to 0.006
3500	3220 to 3710	-0.005 to 0.007
4000	3710 to 4260	-0.005 to 0.007

7-4(M)(5)(ii) Controls Criteria

1. Luminaire shall be fully prewired and shall incorporate an [ANSI C136.41](#) compliant 7-pin receptacle.
2. If a dimmable LED driver is specified, its 0-10V or DALI control wires shall be connected to the receptacle pads as specified in [ANSI C136.41](#); connection of the two remaining pads shall be by Supplier, as directed by Owner.

7-4(M)(5)(iii) Identification Criteria

1. Luminaire shall have an external label per [ANSI C136.15](#).
2. Luminaire shall have an internal label per [ANSI C136.22](#).

7-4(M)(5)(iv) Interference and Power Quality Criteria

1. Luminaire shall comply with [FCC 47 CFR Part 15](#) interference criteria for Class A (non-residential) digital devices.
2. (For residential areas) [FCC 47 CFR Part 15](#) interference criteria for Class B shall be required. Reference [FCC 47 CFR 15.105](#).
3. Luminaire shall comply with section 5.2.5 (luminaires rated for outdoor use) of [ANSI C82.77](#) at full input power and across specified voltage range.

7-4(M)(5)(v) Electrical Safety Testing Criteria

1. Luminaire shall be listed for wet locations by a U.S. Occupational Safety Health Administration (OSHA) Nationally Recognized Testing Laboratory (NRTL).
2. Luminaire shall have locality-appropriate governing mark and certification.
3. Luminaire shall meet the performance requirements specified in [ANSI C136.2](#) for dielectric withstand, using the DC test level and configuration.

7-4(M)(5)(vi) Electrical Immunity Criteria

1. Luminaire shall meet the performance requirements specified in [ANSI C136.2](#) for electrical immunity.
2. Manufacturer shall indicate on submittal form whether failure of the electrical immunity system can possibly result in disconnect of power to luminaire.

7-4(M)(5)(vii) Painted or Finished Surfaces Exposed to the Environment

1. Shall exceed a rating of 6 per ASTM D1654 after 1000 hours of testing per ASTM B117.
2. The coating shall exhibit no greater than 30% reduction of gloss per ASTM D523, after 500 hours of QUV testing at ASTM G154 Cycle 6.

Section 7-4(M)(6) **Street Lighting Development Build out Requirements**

1. In new subdivisions, the developer is required to adhere to the National Electrical Code (NEC) and the International Building Code (IBC) when designing streetlight infrastructure associated with the new development. This includes wiring, voltage drop method, and circuit sizing. The City adopts the most recent versions of the NEC and IBC.
2. The developer shall install a Public Service Company of New Mexico (PNM) Metered Service for all street lighting to allow full measurement of all electrical usage for street lighting luminaires.
3. NEMA 3R - Electrical service disconnecting equipment shall be required to provide life safety to all future maintenance associated with the streetlight infrastructure.
4. Design load calculations shall be required along with permitting and code inspections on all new subdivision developments.
5. In new subdivisions, the developer submits a copy of the plat with required street lighting marked the Traffic Engineer.

6. Once approved, the Traffic Engineer will then forward the street light installation plat to PNM for design of the street lighting system.
7. The developer shall install the street lights and work with PNM on the installation of electrical service to the subdivision.
8. The developer is responsible for charges PNM accesses on customer built / sales agreement contracts to energize subdivision."
9. In new subdivisions, the developer is required to submit 1 hard copy and 1 electronic copy of the final as-built plat (city owned street light facilities only) with required street lighting, junction boxes, termination points, and wire sizing to the Traffic Engineer.
10. The developer shall submit 1 hard copy and 1 electronic copy of the final as-built plat of all facilities installed on behalf of PNM (including existing easements noted).
11. The developer is fully responsible for the construction of the streetlight infrastructure as well as all coordination required with PNM for a completed project. Reference this DPM for required location of streetlights and any specific infrastructure list requirements as applicable.
12. Street light electrical infrastructure wiring shall be aluminum with the standard aluminum label permanently affixed to the exterior of the street light pole above the electrical service hand-hole.
13. All street light poles shall be metal, aluminum, or other approved UL listed materials. Wood poles are prohibited to be used for City assets.
14. The developer shall follow the PNM Electric Service Guide in the design and installation of all electrical power for all street light installations. See the PNM website: <http://www.pnm.com/esg>.

Part 7-4(N) Traffic Control and Development Requirements

Section 7-4(N)(1) Traffic Control & Phasing Plan

1. A critical element to maintaining safe conditions during street construction activities includes traffic control plans and phasing of construction activities. All construction activities shall address these elements through a plan that will identify the phasing of construction activities and the necessary traffic control devices in accordance with the latest edition of the [MUTCD](#).
2. Roadway projects often impede drastically on the pedestrian, bicycle and transit routes. Provisions shall be included in all traffic control and phasing plans for reasonable and continuous access to these modes of traffic.
3. The right-of-way for a street typically accommodates many different underground and overhead utilities. The designer of a construction project needs to coordinate design activities with the other users of the right-of-way including existing and future utilities. The traffic control and phasing plans need to incorporate provisions for these other users.
4. Construction activities within the right-of-way require an excavation permit. Prior to the issuance of the permit, plans must be submitted with appropriate approvals that define the construction activities, appropriate traffic control measure, and evidence of notification through the [811 Call Before You Dig](#).

Section 7-4(N)(2) Traffic Construction and Fees

1. The Department of Municipal Development Construction Services Division (DMD/CSD) is responsible for coordinating most activities conducted in the City right-of-way, including issuance of barricade and excavation permits, inspection of all barricaded sites, etc.
2. During large City construction projects, special events, and during the holiday season, construction moratoriums are instituted to ensure safe and efficient road conditions for the traveling public. Contact SMS/CSD for additional information on construction moratoriums prior to construction.
3. Restoration fees are required on any street that has been newly constructed or has received major reconstruction or maintenance within the past 5 years.

Part 7-4(O) Naming Streets

1. The naming of streets within the City of Albuquerque shall follow [Part 6-5-1 Street Names \(ROA 1994\)](#). The policy applies to all streets that normally provide primary access to abutting property, whether by City right-of-way or by private way.
2. The City Engineer shall approve every new or changed name of a street within its planning and platting jurisdiction.
3. Where a street is or clearly will be both within and outside of the City of Albuquerque, the City shall confer with other local governments and seek a mutually satisfactory name.

Section 7-4(O)(1) Method of Naming

All street names in the city shall be named using any of the following methods:

1. By plat dedicating City right-of-way for an unnamed local or collector street, or by the continuation of a named principal or minor arterial.
2. By the adoption of a surveyed street line with name pursuant to [Part 6-5-3 Future Street Lines \(ROA 1994\)](#).
3. By adoption of a resolution by the City Council concerning the name of a specific principal or minor arterial street.

Section 7-4(O)(2) Street Designations

1. New or the continuation of a principal and minor arterial as defined by LRTS shall be designated "Boulevard".
2. Local and collector streets that run essentially North-South shall be designated "Street" or "Drive."
3. Local and collector streets that run essentially East-West shall be designated "Road" or "Avenue."
4. Local street cul-de-sacs may be designated "Court" or "Place", depending on the length of the cul-de-sac. ("Place" is to be used for cul-de-sacs at or near maximum length).
5. Circular turn-arounds with fewer than 6 lots may not require a street name.
6. An additional street name may be required where the change in direction of the street is greater than 90 degrees in order to comply with [Part 6-5-1 Street Names \(ROA 1994\)](#).
7. In places where the appropriate street designation is not clear, the City Engineer shall determine the designation.

Section 7-4(O)(3) Street Names

1. The name of a new street should be the name of an existing, nearby street that is essentially in line with it, unless the City Engineer finds that such name continuation would not be helpful to motorists searching for an address.
2. If this does not apply, new streets shall be named per the following policies:
 - a. *Grouping of names with similar content, such as: cities, trees, names, etc., is desirable.*
 - b. *Alphabetical sequences of street names, such as: Arizona St., California St., Carolina St., etc., is desirable.*
 - c. *Names with double meaning or names that are difficult to spell or pronounce are usually undesirable.*
 - d. *Names already in use for streets in another area and not essentially in line with the new street are unacceptable.*
 - e. *Names over 13 letters, including spaces, are unacceptable. Street designations, such as Boulevard and Drive, and quadrant designations, such as NE, are not counted toward the 13 allowed letters.*

Section 7-4(O)(4) Procedure

1. To change the name of an existing street, a request is filed with the City Surveyor as the designee of the City Engineer.
2. For new streets, the developer will apply for and submit a preliminary plat for review and approval by the City Surveyor. The City Surveyor will accept the developer's proposal for street names that are consistent with [Part 6-5-1 Street Names \(ROA 1994\)](#) and the previous guidelines. The City Engineer reserves the right to name streets where the City Engineer finds that the developer's name or designation is not consistent with City policies and/or the public welfare.
3. Appeal of the City Engineer's decision is to the Environmental Planning Commission (EPC). The EPC decision may be appealed to the City Council.

Section 7-4(O)(5) Markings

1. Street markings in accordance with the [MUTCD](#) and current [City Standard Specifications](#) shall be included in the construction of new streets.
2. The layout of these markings need to be shown in the plans and included in the work to be performed by the contractor.

Section 7-4(O)(6) Signage

1. Signs shall be installed in accordance with [MUTCD](#) and current [City Standard Specifications](#) in the construction of new subdivisions.
2. For new construction, the layout of these signs need to be shown in the plans and included in the work performed by the contractor.
3. All signs are installed by the developer at the developer's expense.
4. The developer of a subdivision pays a street name sign fee for each intersection at the time of application as set forth in [IDO Section 14-16-5-4 \(Subdivision of Land\)](#).

Section 7-4(O)(7) Traffic Signals

1. See [Section 7-4\(I\)\(6\)](#) for design guidelines and [Part 7-5\(C\) Traffic Study Warranting Criteria](#) for signal warranting information. The determination of

appropriateness and location of traffic signals shall be at the discretion of the City Engineer.

2. The latest edition of the [MUTCD](#) and current [City Standard Specifications](#) shall be used to define the design of these elements. Where traffic signals may be warranted at a future date, the installation of a portion of the future signal elements including foundations, needs to be included in the construction of the streets.
3. Where signalization is not likely in the near future, only the underground conduit and pull boxes need to be constructed.

Section 7-4(O)(8) Barricades at Ends of Pavements Signage

1. A Type III barricade (per [MUTCD](#)) is required at the end of any street pavement within or at the limits of a project regardless of the class of street involved or how soon additional pavement will be placed beyond the current project limits.
2. The only exception is where the Traffic Engineer determines that the unpaved portion of the street beyond the project limits has been and will continue to be open to and used by through traffic.
3. The installation of the barricade must be shown on the plans and included as a part of the street improvements.

ARTICLE 7-5 TRAFFIC STUDIES

Part 7-5(A) Background and Purpose

The City of Albuquerque requires that traffic impacts be considered as part of the development review process. There are two types of traffic analyses that may be required:

1. **Traffic scoping form (TSF):** includes a basic overview of roadway and transportation conditions.
2. **Traffic impact study (TIS):** requires an in-depth examination of the potential impacts of new development on nearby roadways.

The purpose of these studies is to assess the changes to the transportation system that a proposed development may create and to identify transportation improvements (i.e. mitigation measures) to be provided by the site developer to address the impacts of additional traffic associated with the development. This section clarifies the purpose and need of a [TSF](#) and a [TIS](#), when such analyses are required, and the expected structure and contents of a [TIS](#).

TSFs and TISs vary in complexity based on the scale, location, and type of development, and are ultimately intended to ensure that new developments can be accommodated and integrated within the City's transportation system. Design solutions and mitigation measures should be appropriate for the situation, financially reasonable, and balance the needs for site access, through traffic, and the safety of all travelers.

Where a [TIS](#) is required, the Traffic Engineer shall work with the project developer on the scope and parameters of the [TIS](#) and to review the findings of the report.

Traffic scoping forms and traffic impact studies play an important role in identifying appropriate motor-vehicle related improvements, but those strategies must be complementary with other roadway needs. The [ABC Comp Plan](#) establishes transportation policies and priorities that vary based on land development forms and the desired transportation infrastructure for the location. In particular, there are several types of Centers and Corridors where accommodating transit, bicycle, and pedestrian travel must be considered alongside vehicle throughput. (See [Article 7-3 Roadway Design Context](#) for additional information on Centers and Corridors.) Considering the site context is important as not all locations should be treated equally and not all roads should serve the primary function of moving large volumes of cars long distances. Accordingly, acceptable LOS, the typical measure of roadway performance in a [TIS](#), may vary depending on the location, and the same standards cannot be applied equally in all situations.

Part 7-5(B) Traffic Scoping Form and Traffic Impact Study

Section 7-5(B)(1) Traffic Scoping Form (TSF)

The first step in the evaluation of potential roadway impacts of a new development is a [Traffic Scoping Form \(TSF\)](#). All development projects and sites that involve construction of greater than 5,000 square feet of commercial space or generate traffic above basic thresholds require a traffic scoping form. The information provided in the [TSF](#) has 2 purposes:

1. To allow the Traffic Engineer to identify reasonable modifications that can be made to site plans that support the function of the transportation system and ensure safe and efficient access to and from the site to the adjacent roadway.
2. To determine if the site's impacts will meet the thresholds requiring a [Traffic Impact Study \(TIS\)](#). See [Part 7-5\(C\) Traffic Study Warranting Criteria](#).

The traffic scoping form contains information regarding the proposed development, including description of the project uses and expected number of daily visitors. A [TSF](#) must be included alongside the site plan as part of an EPC, DRB or building permit application.

The applicant must submit an estimated number of daily trips generated by the site, as well as during the AM and PM Peak if known; assumptions will be made by the Traffic Engineer if such information is not provided. Depending on the location or magnitude of impacts a full [TIS](#) may be required; otherwise only a [TSF](#) is required. The traffic scoping form should be completed by the applicant and does not require the certification of a licensed engineer. The [TSF](#) shall be submitted before a building permit is issued.

City of Albuquerque staff will review the [TSF](#) and estimated trip generation levels to determine if further actions by the developer are required, including a [TIS](#). Based on the findings of the traffic scoping form, the Traffic Engineer may require mitigation measures for roadway improvements or investments in transit, bicycle, or pedestrian infrastructure.

The [TSF](#) can be found on the City of Albuquerque website at the following link: <http://documents.cabq.gov/planning/DesignReviewServices/TrafficScopingForm.pdf>

Section 7-5(B)(2) Traffic Impact Study (TIS)

Where weekday levels of traffic are expected to exceed certain thresholds, a [TIS](#) shall be required. (See [TABLE 7.4.75](#) and [Part 7-5\(C\) Traffic Study Warranting Criteria](#).) Unlike a traffic scoping form, where the requirements include a basic assessment of existing conditions, the expectations for a [TIS](#) are much greater. In particular, the [TIS](#) must consider the LOS for roadway segments affected by the proposed development. In addition to the impacts of the proposed development, potential mitigation measures on travel patterns in the project "influence area" should be evaluated. If the scale of the project is large enough, a traffic impact study may require analysis utilizing socioeconomic forecasts

and should consider travel demand model results from the most recent approved dataset from MRCOG.

A [TIS](#) includes all of the following:

1. Review of existing conditions
2. Proposed site characteristics, including land uses and projected phasing of the development
3. Vehicle trips generated by the development site
4. Traffic analysis of affected intersections and roadways as a result of planned development
5. Site access requirements
6. Summary of findings
7. Mitigation measures

The [TIS](#) must be completed by a professional engineer licensed in the State of New Mexico, preferably with a PTOE certification and experience in preparing Traffic Impact Studies. A [TIS](#) shall be considered valid for 3 years from the date of approval by the Traffic Engineer.

An update to the trip generation analysis may be required if there is a change in the development or land use from the approved [TIS](#).

Upon approval by the Traffic Engineer, an update to the trip generation analysis may also be used in lieu of a new [TIS](#) if more than 3 years have passed since the approval of the original [TIS](#) and no significant changes to the site or surrounding area have taken place.

See [Part 7-5\(E\) TIS Report Elements](#) below for the full set of requirements for a [TIS](#).

Part 7-5(C) Traffic Study Warranting Criteria

Warranting criteria are used to determine if a [TSF](#) or a [TIS](#) is required as part of the following development activities:

1. Zoning Map Amendment (Rezoning)
2. Building permit for new building or change of use resulting in traffic above the levels in [TABLE 7.5.87](#)
3. Site plan
4. Subdivision
5. Master Development Plan

A [TIS](#) is generally required based upon the scale of the project and expected levels of traffic generation. [TABLE 7.5.87](#) indicates the conditions that warrant a [TSF](#) or [TIS](#) by location. In all instances where "TIS" is indicated in the table, a traffic scoping form must first be completed by the applicant and reviewed by the Traffic Engineer before a TIS should begin. The trip generation levels indicated in [TABLE 7.5.87](#) are based on site characteristics provided by the developer and reviewed by the Traffic Engineer. Volume-to-capacity (V/C) levels are calculated by the MRCOG Congestion Management Process and based on current roadway conditions. This data is available for all collector and arterials roadways in the City of Albuquerque through the [Transportation Analysis & Querying Application](#) (TAQA) tool.

Projects may be exempt from a TIS depending on their location or if the impacts are below certain thresholds. Regardless of the expected trip generation rates, large development projects are exempt from a TIS if the site is located Downtown, in an Urban Center, or within 660 feet of a Premium Transit station. The locations exempt from a TIS are marked by high degrees of non-automobile travel, lower parking requirements, and are typically zoned for mixed-use development, which reduces trip generation levels.

TABLE 7.5.87 Traffic Analysis Requirements by Location

	10-100 AM or PM peak hour trips	10-100 AM or PM peak hour trips	> 100 peak hour trips; Existing V/C <0.5	> 100 peak hour trips; Existing V/C >0.5
Center	Premium Transit Station	TSF	TSF	TSF
	Downtown	TSF	TSF	TSF
	Urban Center	TSF	TSF	TSF
	Activity Center	TSF	TSF	TIS
	Employment Center	TSF	TSF	TIS
Corridor	Major Transit	TSF	TSF	TIS
	Multi-modal	TSF	TSF	TIS
	Commuter	TSF	TIS	TIS
	Other / No Designation	TSF	TIS	TIS
	Main Street	TSF	TSF	TSF

Section 7-5(C)(1) TSF Warranting Criteria

A [TSF](#) is required for the following projects or sites:

1. Project/site generates 10 total trips during the AM or PM peak hour
2. Project/site contains more than 10 residential units
3. Project/site where uses have not yet been identified
4. Project/sites with a drive thru lane (e.g. fast food restaurant)
5. Project/sites with gas station and/or convenience center
6. Project/site contains a non-residential use of more than 5,000 feet
7. Tenant improvement application generating additional 10 total trips during the AM or PM peak hour

A [TSF](#) may also be required or waived at the discretion of the Traffic Engineer. The Traffic Engineer will review the results of the traffic scoping form and make a determination if a [TIS](#) is required.

Generally, a [TSF only](#) – and not a TIS – is required under any of the following circumstances:

1. The project will result in fewer than 100 AM or PM peak hour trips.

2. The project is located Downtown, within an Urban Center, or within 660 feet of a Premium Transit station.
3. The project is located along a Main Street Corridor.
4. The project will generate more than 100 weekday AM or PM peak hour trips and is located along a roadway where the existing AM or PM peak hour volume-to-capacity (V/C) ratios are below an average of 0.5.

If the Traffic Engineer determines that a roadway abutting a project site is fully constructed and auto-oriented mitigation measures are impractical or unlikely to improve vehicle LOS, a traffic scoping form only may be required instead of a [TIS](#). In these circumstances, the project may still be subject to non-auto oriented mitigation measures as determined by the Traffic Engineer, such as improved sidewalks, transit amenities, etc. See [Section 7-5\(E\)\(9\) Recommendations & Mitigation Measures](#) for more information on potential mitigation measures.

Section 7-5(C)(2) TIS Warranting Criteria

A [TIS](#) may be required depending on the results of the [TSF](#). A [TIS](#) is warranted under either of the following conditions:

1. The project will generate more than 100 AM or PM peak hour trips per day and is located along a Commuter Corridor or non-designated or “other” corridors.
2. The project will result in more than 100 AM or PM peak hour trips per day and is located in a Center or along a Corridor where the AM or PM peak hour volume-to-capacity ratios already exceed 0.5. Exceptions include Downtown, Urban Centers, Premium Transit station areas, and Main Street Corridors.

Part 7-5(D) Traffic Analysis Procedures

Section 7-5(D)(1) Traffic Scoping Form

A [TSF](#) contains an initial analysis performed by the site developer and reviewed by the Traffic Engineer to consider general impacts associated with the site. The following items are required in a traffic scoping form:

1. Development information, including proposed land use and site activities
2. Facility type(s), including square footage and number of residential and/or commercial units.
3. Traffic considerations, including estimated number of daily trips to the site (i.e. trip generation).
4. Presence and general condition of pedestrian and bicycle facilities within and across the study area.
5. Preliminary site plan (include building size in square feet).
6. Other items as requested by the Traffic Engineer.
7. The Traffic Engineer will review the traffic scoping form to determine if a full [TIS](#) is required. Additional considerations in the determination of whether a [TSF](#) is sufficient or if a [TIS](#) is required include:
8. Location in a Center or along a Corridor
9. Daily traffic volume and peak hour link volume-to-capacity ratios (most current existing – available via the [TAQA tool](#))
10. Presence of transit, bicycle, and pedestrian infrastructure

Section 7-5(D)(2) Traffic Impact Study (TIS)

7-5(D)(2)(i) Draft TIS Scoping Letter

If a [TIS](#) is deemed necessary, the site developer must prepare a draft [TIS](#) scoping letter that proposes the parameters for the [TIS](#) and identifies a study area. Potential parameters in the scoping letter may include:

1. Study area limits
2. Single or multi-phases of development
3. Site trip generation assumptions, including pass-by and internal capture trips
4. Adjacent developments
5. Other growth estimates
6. Build-out phases/horizon year
7. Capacity analysis/LOS analysis
8. Multi-modal considerations
9. Crash/safety considerations
10. Other planned or programmed roadway improvements
11. Other planned developments with background traffic
12. Neighborhood concerns
13. Applicable codes and public policies

7-5(D)(2)(ii) TIS Scoping Meeting

The Traffic Engineer will review the [TIS](#) scoping letter and schedule a [TIS](#) scoping meeting with the site developer and affected agencies to confirm the parameters of the [TIS](#). Data collection needs will be defined at this time. Vehicular and non-motorized traffic counts may be required for intersections within the study area, or as directed by the Traffic Engineer. All additional topics and the agreed upon [TIS](#) parameters shall be summarized in a final [TIS](#) scoping letter. This document shall be included in the appendix of the [TIS](#).

7-5(D)(2)(iii) TIS Report Preparation and Review

The developer shall collect traffic data and prepare a [TIS](#) according to the agreed upon parameters. The developer will prepare the [TIS](#) with the elements listed in [Part 7-5\(E\)](#) and begin identification of and traffic, transit, or pedestrian mitigation measures. The City will review the [TIS](#) and provide comments as needed.

7-5(D)(2)(iv) Mitigation Measures

Mitigation measures should be proposed in the draft [TIS](#) as a way to moderate traffic generated by the development. Recommendations shall follow [Section 7-5\(E\)\(9\) Recommendations & Mitigation Measures](#) and consider a complete streets solution. The City and the developer will come to an agreement on the extent and nature of mitigation measures, and those measures will be included in the final [TIS](#).

Steps in TSF and TIS Report Preparation and Review (in order):

- a. TSF submitted by developer.
- b. Review of TSF by City Traffic Engineer (Follow steps c-j if a TIS is required).
- c. Draft TIS scoping letter submitted by developer.
- d. City review of TIS scoping letter.
- e. TIS scoping meeting to confirm TIS parameters.
- f. TIS report preparation and submittal by developer.
- g. Review of draft TIS report by City staff. Staff comments provided.
- h. Identification and agreement of mitigation measures (additional meeting for negotiation may be required).
- i. Submit final TIS report.
- j. City approval of TIS.

TIS Report Elements

1. Executive Summary
2. Introduction
3. Existing Conditions
4. Proposed Site Traffic Characteristics
5. Future Traffic Conditions and Analysis Years
6. Traffic Analysis
7. Site Access Requirements
8. Summary of Findings
9. Recommendations and Mitigation Measures
10. Appendix

Part 7-5(E) TIS Report Elements

The [TIS](#) shall include the following elements. Revision of requirements may be requested on a case-by-case basis at the [TIS](#) scoping meeting.

Section 7-5(E)(1) Executive Summary

The Executive Summary should include the following items:

1. Site location and study area
2. Development description and timeframe for completion
3. Summary of findings
4. Recommendations and mitigation measures

Section 7-5(E)(2) Introduction

7-5(E)(2)(i) Study Purpose

A general statement describing the intent of the report, and the reason it is being submitted (e.g. in support of a site plan, subdivision, etc.).

7-5(E)(2)(ii) Study Procedures

1. Information sources: The applicant must provide documentation of their sources for trip generation and other factors related to expected travel demand within the influence area(s).
2. Scope: The influence area encompasses the roadway elements that are assumed to be impacted by the proposed development. The influence area must be confirmed by the Traffic Engineer in the initial scoping meeting with the study preparer. The scope should consider the timeframe for site development.
3. LOS: The desired LOS for signalized intersections varies depending on the location, with lower levels of service and higher levels of congestion acceptable in Centers and along certain Corridors as generally identified in [ABC Comp Plan](#) Policies 6.1.4 through 6.1.9. This approach acknowledges that vehicle throughput and reduced auto delay is not the only objective in many situations. See [TABLE 7.5.88](#) for acceptable LOS by location and

corridor type and [TABLE 7.5.89](#) for acceptable LOS along Main Street Corridors.

4. Outside of designated Centers, the standard LOS for most arterials shall be LOS D where the roadway is controlled by traffic control devices (i.e. signalized or stop controlled intersections). For intersections, this applies to the average for each approach; however, the LOS for all approaches and movements must be reported in the [TIS](#).

TABLE 7.5.88 Desired LOS by Location and Corridor Type

Functional Classification & Roadway Type	ABC Comp Plan Center Type						
	Transit Station Area	Downtown	Urban Center	Activity Center	Village Center	Employment Center	Outside Center
Premium Transit	E-F	E-F	E-F	E-F	E-F	E-F	E-F
Major Transit	E	E-F	E	E	D-E	D-E	D-E
Multi-modal	E	E	E	E	D-E	D-E	D-E
Commuter	E	E	D-E	D-E	D-E	D-E	D
Other Arterial	E	E	E	D-E	D-E	D-E	D
Minor Arterial	E	E	D-E	D-E	D-E	D	D
Collector	E	D-E	D	D	C-D	C-D	C-D

TABLE 7.5.89 LOS for Main Street Corridors

LOS	E
Design Speed	25-30
Priority Travel Mode	Pedestrian

Section 7-5(E)(3) Existing Conditions

The description of existing conditions should refer to data that is no more than 3 years old. This information should include all of the following:

7-5(E)(3)(i) General Area Characteristics

1. Location within the City of Albuquerque (vicinity map).
2. General land use development adjacent to and at the site.
3. Existing zoning at the site and for adjacent lands.
4. Site plan including existing and proposed access locations.
5. Other planned and approved developments, including description of the location and type of other planned and approved developments in the influence area (the City will provide required information).

7-5(E)(3)(ii) Area Street Network

A detailed description of the street network in the influence area, including major roadways, and all information necessary for capacity analysis.

7-5(E)(3)(iii) Existing Traffic Volumes

The [TIS](#) may use data from the MRCOG Traffic Counts Program for link-level data for all arterials and collectors in the influence area. (See the [TAQA tool](#).) An applicant should collect their own data if conditions have changed since the most recent count or if there is reason to believe the available counts are inaccurate.

For intersections where existing traffic counts and/or turning movement counts are not available, the applicant may be required to collect traffic counts data. The duration of the traffic counts and location of turning movement counts will be determined in consultation with the Traffic Engineer during the [TIS](#) scoping meeting. As the peak hours are the primary interest in the [TIS](#), the turning movement counts can generally be limited to a 4-hour turning movement count, with 2 hours in the AM peak period and 2 hours in the PM peak period. Longer count times may be required by the Traffic Engineer if the existing intersection is known or expected to warrant a traffic signal; additional traffic volume data may also be requested to evaluate the need for traffic signalization.

7-5(E)(3)(iv) Existing Levels of Service

A description of the existing LOS for the study intersections using the latest version of a traffic analysis software approved by the Traffic Engineer.

7-5(E)(3)(v) Existing Transit Service

A description of the existing services, including frequency and span of weekday service, regional destinations served by adjacent transit service, as well as transit service amenities and bus stops in the project influence area. All proposed transit services in the influence area should be described.

7-5(E)(3)(vi) Bicycle and Pedestrian Considerations

A description of the type and quality of pedestrian and bicycle infrastructure, including pedestrian access to transit stops. Gaps in the bicycle and pedestrian network in the influence area must be identified. Bicycle and pedestrian counts are required for sites or projects located in high pedestrian or bicycle activity areas (see section 23-3.5), and may be requested by the Traffic Engineer as part of vehicle counts data collection efforts.

7-5(E)(3)(vii) Safety Evaluation/Crash Data

An evaluation of crashes over the 3-5 most recent years for which data is available and other safety considerations may be required.

Section 7-5(E)(4) Future Traffic Conditions and Analysis Years

7-5(E)(4)(i) Project Implementation Year

Traffic forecasts shall be developed for the year the development is expected to be completed. Phased analysis may be required depending on the size and scale of the project, or as directed by City staff. Large projects with regional

impacts may require that additional phases of development be evaluated, including horizon year analysis. Traffic volumes must account for 3 conditions: Site traffic, Growth in through traffic, other planned development.

7-5(E)(4)(ii) Site Traffic

The sum total of traffic attributable to the site development in the implementation year. The site traffic, or build traffic, plus the background traffic represents the total traffic on the study area roadway system.

7-5(E)(4)(iii) Growth in Through Traffic

Through traffic can be estimated using growth factors based on the most recent 10 years of historical volume data. The use of growth factors is most appropriate for development periods of 5 years or less.

Growth rates should be based on a 10-year historical growth derived from the MRCOG Traffic Flow Maps. The minimum annual growth rate to be used is 0.5%. Growth rates should be defined in the [TIS](#) scoping letter and reviewed with respect to reasonableness in comparison to roadway capacity limitations and the long-range traffic forecast from the MRCOG regional travel demand model. Growth rates may also consider recent developments and their impacts on traffic volume patterns in the study area.

7-5(E)(4)(iv) Other Planned Development

Other off-site development that is to occur prior to the project implementation year must be accounted for, and the traffic associated with this development must be included in the analysis. Where previous impact studies have been produced, the City will provide relevant data to the applicant.

The sum of the existing traffic, growth in through traffic, and the traffic generated by off-site development in the study area represents the background traffic for the implementation year analysis.

7-5(E)(4)(v) Consideration of Programmed Roadway Improvements

Transportation system improvements in the influence area that are programmed or committed to occur during the forecast period should be included in the analysis. The study should cite all projects in the influence area included in the City's Capital Improvement Program and the region's Transportation Improvement Program (facilitated by MRCOG).

Section 7-5(E)(5) Proposed Site Traffic Characteristics

7-5(E)(5)(i) Site Development Characteristics

The development characteristics must include the following:

1. An estimate of implementation phasing of the proposed development, to include the location and estimated year of occupancy of each phase

2. The specific type of land use to be implemented in each project phase; for example, gas station, hotel, residential dwelling units, etc., and the size and of type of proposed development (e.g. square feet of commercial space, number of dwelling units, etc.). The land use type and intensity should be expressed in the same terms as indicated in the [ITE Trip Generation Manual](#) for a given land use type.
3. Proposed access locations for each project phase, indicated on a drawing of the roadway network and showing intersections of interest, as defined in the scoping letter, and proximity to existing or proposed signalized intersections on the adjacent roadway system.

7-5(E)(5)(ii) Trip Generation

Provide a table showing the trips generated for the proposed development, and other planned developments in the influence area. Data for other planned developments may be provided by the City, including previous impact studies, as appropriate. The source of trip generation rates shall be from the current edition of the [ITE Trip Generation Manual](#) or other resources sponsored by the [ITE Transportation Planning Council](#). Assumptions regarding the types of trips (e.g. pass-by, diverted link, primary, etc.) must be clearly stated, and discussed with City staff at the scoping meeting. The influence area varies depending on the size of the development.

Other trip generation rates that represent local or site-specific conditions (e.g. mixed-use trip generation rates) may be used as prescribed by the Traffic Engineer, or as suggested by the study preparer and agreed to by the Traffic Engineer. In the latter case; however, the burden of justifying the validity and use of trip rates other than those in the ITE manual is on the study preparer.

7-5(E)(5)(iii) Other Trip Generation Considerations

1. Pass-by Traffic and Internal Capture
In the [TIS](#) scoping letter, the applicant will identify the amount of any pass-by or internal capture trips that will be used in the traffic analysis.
 - a. *Pass-by refers to the existing trips along a route that may visit the site*
 - b. *Internal capture is the result of mixed-use activity in which 1 trip to the site results in visits to multiple businesses, or if there are trips to the new development that are generated within the site, such as in a development with a residential component. See [ITE Trip Generation Manual](#) for additional guidance.*These assumptions shall be reviewed by the City, with Traffic Engineer approval documented in the response to the scoping letter or other formal written communication.
2. Transit
For sites in Centers or along Premium Transit and Major Transit Corridors, a percentage of trips to the site may be assumed to be completed via transit. This rate should be consistent with transit mode share data for the region or the corridor, if available, or based on a national study or reference manual.

7-5(E)(5)(iv) Trip Distribution

Trip distribution shall be the percentage of traffic travelling a specific route to or from the site that passes through the intersections of study determined in the

TIA scoping letter. The trip distribution informs the traffic assignment discussed below. This distribution is to be determined using the most recently-approved socioeconomic forecast from the MRCOG and will be based upon appropriate radii or distribution areas around the site, depending on the type of development. Land uses that serve regional markets should consider potential trips generated from a larger radius. The study area(s) and trip distribution methodology must be approved by the Traffic Engineer at the scoping meeting.

7-5(E)(5)(v) Traffic Assignment

The number of trips entering and exiting the study site. These assignments will generally be required for both the morning and evening peak hour conditions. Assignment to specific movements and intersections will use logical routing onto the major street system and intersections of study. All trips shall be assigned to the access points, and all primary trips shall be assigned to the off-site intersections that will be evaluated within the study area. Pass-by trips should only assigned to the site access points and internal capture trips should not be assigned to an access.

Section 7-5(E)(6) Traffic Analysis

7-5(E)(6)(i) Intersection and Roadway Analyses

1. Identify intersections and roadways to be studied (includes all site access points).
2. Identify existing signal timing patterns for signalized intersections (to be provided by the Traffic Engineer).
3. Calculate intersection LOS and link-level volume-to-capacity ratios for the AM and PM peak periods under the following conditions:
 - a. Existing traffic (link-level data available through the [TAQA tool](#))
 - b. Project implementation year (includes other planned developments)
 - i. Baseline scenario, without proposed development (background traffic only)
 - ii. Build scenario, with proposed development (background plus site traffic)
4. The analysis of existing, or other warranted, signalized intersections shall be based on the operational/design procedures in the [HCM](#) or equivalent document as approved by the Traffic Engineer for the project implementation year.
5. Analysis of unsignalized locations, including major access driveways shall be based on the methodology contained in the [HCM](#), or an alternative approach approved by the Traffic Engineer.
6. Assumptions regarding vehicle queuing, peak hour factors, heavy vehicle percentages, arrival types, right-turns-on-red, etc. may be included in the [TIS](#) report as needed.

7-5(E)(6)(ii) Identify Alternative Intersection and Roadway Designs

Alternative configurations shall be proposed for each intersection and roadway that fails to maintain the standard levels of service in the implementation year when considering either of the following conditions:

1. Background traffic only

2. Background plus site traffic

General description of roadway and intersection improvements are required for the implementation year, as deemed appropriate by the Traffic Engineer. The Traffic Engineer may waive this requirement if additional capacity is not feasible.

7-5(E)(6)(iii) Evaluate Alternative Intersection and Roadway Designs

The link-level capacity and intersection LOS of each of the alternative intersection and roadway designs shall be determined using the operational/ design procedures of the most current [HCM](#) for the implementation year. Intersection analysis may be performed for the horizon year using the planning or operational methods of the most current [HCM](#), or as deemed appropriate by the Traffic Engineer.

7-5(E)(6)(iv) Perform Signalization and Stop Sign Warrant Analyses

All locations meeting signal and stop sign warrants based on traffic volume in the implementation year should be identified. If an intersection is found to meet signal warrants based on the criteria contained in the [MUTCD](#) in the project implementation year, a signalized intersection operational analysis shall be performed using the procedures contained in the [HCM](#). Recommendations for signal installation should be made as signal warrants are met. Upon review of the recommendations contained in the [TIS](#), the Traffic Engineer will make a determination of whether the signal should be installed and/or provisions made for future signal installation. This determination shall be included in the final copy of the [TIS](#).

Section 7-5(E)(7) Site Access Requirements

A description of the improvements needed to meet design and operational standards both on and off site. Required contents include the following:

1. Site Access and Circulation Plan
2. Roadway improvements
 - a. On-site
 - b. Off-site
 - c. Implementation phasing
3. Transportation System Management actions
4. Site design features such as turning lanes, median cuts, queuing requirements and site circulation, including driveway signalization and visibility.

Section 7-5(E)(8) Summary of Findings

A summary of the major implications of the proposed site development, including potential changes in LOS and other transportation conditions. Other considerations in this section may include discussion of illumination, traffic control alternatives, and observed deficiencies that are not identified through the analyses.

Section 7-5(E)(9) Recommendations & Mitigation Measures

Actions required to ensure that the roadway(s) affected by the project meet design and operations standards and to provide appropriate accommodations for bicyclists and pedestrians in the project area. Recommendations and mitigation measures should respond to the summary findings from the [TIS](#).

Mitigation measures may be related to roadway improvements, including intersection improvements or changes to the roadway configuration, as well as infrastructure for alternative travel modes (i.e. transit, bicycle, or pedestrian improvements). Appropriate mitigation measures depend on the location and the desired infrastructure improvements in the project location. See [ABC Comp Plan](#) Chapter 7 Urban Design (7.A.6.2) and [Article 7-3 Roadway Design Context](#) for additional information.

Multi-modal LOS analysis should be used as a diagnostic tool when identifying alternative mode mitigation measures and for evaluating the potential impacts of roadway-oriented mitigation measures in high bicycle and/or pedestrian activity areas.

7-5(E)(9)(i) Roadway Mitigation Measures

Mitigation measures may be requested following the completion of the traffic scoping form and a [TIS](#), and must be proposed as part of a [TIS](#) if the impacts of project cause the roadway LOS to exceed the standards prescribed for the project location.

The Traffic Engineer may determine that auto-oriented mitigation measures are not required because the roadway is fully constructed, no additional right-of-way is available, or if no measures are practical because the LOS cannot be substantially improved. In such cases alternative mode mitigation measures may be required.

Roadway mitigation measures may include, but are not limited to, the following:

1. Access management: closure of access points as part of a new development on a fully built-out street.
2. Geometric improvements: turn lanes and other auxiliary lanes
3. Street restriping: additional travel lanes within existing right-of-way or reallocation of lane widths.
4. Street widening and other physical improvements: additional travel lanes or other capacity expansion techniques; these measures must be demonstrated to be physically feasible.
5. Traffic signal operations improvements – upgraded signals, signalization of un-signalized intersection, signal optimization, etc.
6. Transit capacity improvements – contributions toward expanded transit service.

7-5(E)(9)(ii) **Alternative Mode Mitigation Measures**

The goal of non-motorized mitigation measures is to reduce the demand for trips by single-occupancy vehicles and to increase opportunities for travel by alternative modes.

Mitigation measures may be related to the desired infrastructure improvements for the corridor type. Improvements to sidewalks and the pedestrian realm, transit amenities, and bicycle infrastructure may be requested as a mitigation measure in lieu of a roadway improvement.

Alternative mode mitigation measures are most appropriate along the corridor fronting the site or at adjacent intersections in Centers and Premium Transit station areas and along Major Transit, Multi-modal, and Main Street Corridors.

Multi-modal accommodations are required in all circumstances for the frontage to the site and City right-of-way within the development. These accommodations may include:

- *Bicycle infrastructure – bicycle lanes, bicycle buffers, bicycle paint*
- *Connect sidewalk to curb for transit landing area*
- *Mid-block pedestrian crossings / HAWK signals*
- *On-site bicycle racks*
- *On-street parking*
- *Pedestrian connection from site to transit stop*
- *Restriping plan with narrower traffic lanes*
- *Street trees/landscape buffers*
- *Transit station amenities (e.g. but stop bench or shelter)*
- *Widen sidewalks/bring sidewalks into ADA/PROWAG compliance*

Transportation demand management strategies may be proposed to offset or reduce trip generation through carpool or ridesharing programs, contributions to transit service, on-site facilities for bicyclists, among other options.

Part 7-5(F) Neighborhood Impact Assessment (NIA)

The Curb cut ordinance requires the preparation of an NIA for all public, private or charter schools requesting access to City of Albuquerque streets.

- *Charter school: A public school established under the authority of §§ 22-8B-1 to 22-8B-17.1 NMSA 1978.*
- *Private school: A school established, conducted and primarily supported by a non-governmental entity in which instruction is offered by 1 or more teachers and is discernible as a building or group of buildings generally recognized as an elementary, middle, junior high or high school or any combination of those.*
- *Public school: As defined at § 22-1-2 NMSA 1978 a part of a public school district that is a single attendance center in which instruction is offered by 1 or more teachers and is discernible as a building or group of buildings generally recognized as either an elementary, middle, junior high or high school or any combination of those and includes a charter school.*

Section 7-5(F)(1) NIA Purpose/Scope

A NIA is a process to evaluate the overall effects that may result from the approval of curb-cut applications to allow access to public rights-of-way from public, private or charter schools, and to identify methods to mitigate such impacts to a reasonable level.

1. The permit applicant shall schedule an NIA scoping meeting for the NIA following the procedures as listed in [Section 7-5\(D\)\(2\) Traffic Impact Study \(TIS\)](#).
2. The traffic engineer will determine at the NIA scoping meeting whether a Site Traffic Assessment (STA) or a [TIS](#) is required.
3. An STA: analysis of site access (driveways), the need for turn lanes in advance of the site and impacts on signals downstream and upstream of the site. An STA is a lower level of analysis than a [TIS](#).

Section 7-5(F)(2) NIA Minimum Requirements

An NIA shall include, at a minimum, all of the following:

4. A description of the project.
5. The baseline community data that identifies existing conditions with respect to adjacent land uses, traffic patterns, traffic turning movements and volumes, nearby multimodal transportation options, area pedestrian movements, and any other relevant information as determined at the time of scoping.
6. An analysis of the neighborhood impacts, if any, including but not limited to:
 - a. *Impacts on pedestrian and bicycle circulation, and pedestrian and bicycle routes.*
 - b. *Potential automobile and pedestrian conflict points.*
 - c. *Potential noise and air quality impacts resulting from stacking of idling vehicles or vehicle circulation.*
 - d. *Consistency with existing or planned transit routes and stops.*
 - e. *Other potential impacts as determined by the Planning Director, City Engineer, or their designees.*
7. If required, a [TIS](#) as described in [Section 7-5\(B\)\(2\)](#).
8. An STA, shall be conducted by a professional engineer licensed in the State of New Mexico with traffic engineering experience. The STA shall include an appendix with support data for analysis and capacity analysis and shall be signed and sealed in compliance with city standards by the engineer that prepared the report. At minimum and as more fully defined at the time of NIA scoping, it shall address all of the following:
 - a. *The impact that motorists arriving and departing from the school site will generate on traffic operations in the general vicinity.*
 - b. *The site's total capacity for student enrollment.*
 - c. *Anticipated student enrollment.*
 - d. *Scope of required analysis.*
 - e. *Need for a student drop off and pick-up queuing lane.*
9. An evaluation of reasonable alternatives, if any, and their anticipated effectiveness in mitigating potential impacts. The NIA shall include a justification by the applicant for the selection of a particular alternative or why no other reasonable alternatives existed.

ARTICLE 7-6 DEFINITIONS

A

Access Local Street	Access local streets are loop streets, cul-de-sacs, and short segments that provide connections to other streets. Access locals are not continuous for more than 1 or 2 blocks. Anticipated ADT for access locals is 250 vehicles per day or less.
Activity Center (ABC Comp Plan)	Activity Centers provide convenient, day-to-day services at a neighborhood scale to serve the surrounding area within a 20-minute walk or a short bicycle ride.
ADA Accessible Parking	An area on street or in a private property delineating a vehicular parking spot that is accessible to all, including those with physical disabilities.
Angled Parking	An area on street or in a private property delineating a vehicular parking spot at an angle from the curb or access aisle.
Arterial/Collector Spacing	The distance between major roads along a corridor.
Average Daily Traffic (ADT)	The average 24 hour volume of vehicles, being the total volume during a stated period divided by the number of days in that period. Normally, this would be periodic daily traffic volumes over several days, adjusted for days of the week or seasons of the year.

B

Basic Transit Stop	Consists of an accessible boarding and alighting area with easily identifiable signage indicating the location of the stop.
Bicycle Boulevard	Enhanced bicycle routes designed to encourage the through-movement of bicycles while maintaining local access for motor vehicle travel.
Bicycle Buffer	The physical space that separates bicyclists from motorists.
Bicycle Facilities	Facilities including on-street bicycle lanes, separated multi-use paths, and buffers that provide additional comfort and safety for cyclists
Bicycle Lane	A lane on the roadway that has been designated by striping and pavement markings for preferential and exclusive use by bicyclists.
Bicycle Parking	An area on street or in a private property delineating a bicycle parking spot with a bicycle rack.
Bicycle Route	Designated roadways in which cyclists share roadway space with motorists.
Block length	The length of roadway between two intersections.
Bus Bays	A dedicated zone on the side of a roadway for passenger boarding and alighting that prevents travel lanes from being blocked when buses stop to pick up and drop off passengers. Bus bays have a protected zone with entrance and exit tapers.
Bus Turnouts	A dedicated zone on the side of a roadway for passenger boarding and alighting that prevents travel lanes from being blocked when buses stop to pick up and drop off passengers.

C

Center (ABC Comp Plan)	Area of relatively intense development characterized by a variety of uses that allow for many different activities. When capitalized, refers to Centers as designated by the ABC Comp Plan.
Channelized Right Turn Lanes	An intersection type that provides for free-flow or nearly free-flow right turn movements usually with the use of curb islands.
Charter School	A public school established under the authority of NMSA 1978 §§ 22-8B-1 to 22-8B-17.1.
Community Principal Arterial	An arterial street designed to ensure that a particular mode is not to be prioritized at the expense of others, and that the corridor is meant to bring people to an area as opposed to through the area (as is the case with regional principal arterials).
Commuter Corridor (ABC Comp Plan)	A higher-speed and higher-traffic volume route for people traveling across town, usually via limited-access roadways.
Corridors (ABC Comp Plan)	A network of roadways that collectively meet the travel needs of Albuquerque and Bernalillo County residents.
Complete Streets	Roadway(s) with cross sections built at a human scale, designed and operated for equal access by all users, including pedestrians, bicyclists, motorists and transit riders of all ages and abilities, to allow comfortable and convenient street crossings, and pedestrian access to adjacent land uses.
Controlled Pedestrian Crossing	A location where vehicles are managed with traffic control devices that may facilitate pedestrian crossing.
Corral	A pen or enclosure for use in bicycle or motorcycle parking.
Cross Slope	The slope measured perpendicular to the direction of travel.
Cul-de-sac	Short streets intersecting another street at one end and terminating at the other end with a vehicular turnaround.
Curb and Gutter	The area along the edge of a street that separates the elements in the Pedestrian Realm from the Travel Way and serves an important role in stormwater management.
Curb extensions	A traffic calming measure, primarily used to extend the sidewalk, and to reduce the crossing distance for pedestrians.
Curb Radius	The curvature along the curb line.
Curb Ramp	Provides access between elevated pedestrian facilities and road surfaces at pedestrian crossings.
Curb Ramp Counter Slope	The change in grade at the bottom of the curb ramp and adjoining road surface.
Curb Return	The curved section of curb connecting a street to an intersecting street or driveway.

D

Dedicated Transit Infrastructure	The portion of the road or right-of-way allocated exclusively for transit vehicles and associated improvements.
----------------------------------	---

Design Speed	The speed motorists are intended to travel under free-flow traffic conditions.
Design Vehicle	The least maneuverable vehicle that routinely uses a street or a facility.
Designated Pedestrian Crossing	The location where pedestrians are encouraged to cross a roadway, as indicated by a combination of signal devices, signage, or pavement markings.
Detectable Warning Surface (DWS)	Distinctive surface pattern of domes detectable by cane or underfoot that alert people with vision impairments of their approach to street crossings and hazardous drop-offs, such as elevated transit loading area.
Diagonal Curb Ramps	A curb ramp located at the corner of an intersection that directs the user to the center of the intersection.
Directional Curb Ramps	A curb ramp with a running slope that is in-line with the direction of sidewalk travel.
Downtown	Albuquerque's Downtown serves as a regional hub for concentrated job and commercial activity supported by high-density housing and includes a wide variety of land uses.
Drivepad	The portion of a driveway in the right-of-way that connects a street to a commercial or residential driveway.
Driveway	An area on private property where vehicles and bikes are operated or allowed to stand.
E	
Effective Curb Radius	The curvature vehicles follow when turning at an intersection.
Employment Center	Employment Centers are intended to remain predominately industrial, business, and retail centers.
F	
Frontage Zone	The segment between the sidewalk and the property line, which may be located within City right-of-way.
H	
Hammerhead Street	Short street intersecting another street at one end and terminating at the other end with a vehicular turnaround.
High Bicycle Activity Areas	Facilities approaching and within an ABC Comp Plan Center, Premium Transit station area, or school. Other high activity areas include neighborhoods with an average residential density of 10 units per acre or more.
High Pedestrian Activity Areas	ABC Comp Plan Centers, Main Street Corridors, and Premium Transit station areas, as well as areas surrounding big box stores or clusters of retail activity, school zones, locations where buildings with zero setback are present, and neighborhoods with an average density of 10 units per acre. Multi-modal and Major Transit Corridors may also be considered high pedestrian activity areas depending on the surrounding land uses.
High Volume Traffic Generators	A site with over 25 vehicles entering or exiting per hour.

I

- Intersection The location where two roadways (public or private) intersect.
- Intersection Crosswalk The pedestrian path across an intersection, whether it is marked or not.
- Intersection Sight Distance The distance required for drivers to be able to see a control device well in advance of performing a required action.

K

- Keyway An area at the end of dead-end parking aisles for the maneuverability of vehicles.

L

- Landscape/ Buffer Zone An area between the curb and the sidewalk that provides space for signage, utilities, storm water catchment, landscaping, street furnishings, and driveway aprons.
- Level of Service (LOS) A qualitative measure used to relate the quality of motor vehicle traffic service. LOS is used to analyze roadways and intersections by categorizing traffic flow and assigning quality levels of traffic based on performance measure like vehicle delay, speed, density, congestion, etc.
- Long Range Bikeway System (LRBS) The regional network consisting of all existing and proposed bikeway and trail facilities.
- Long Range Roadway System (LRRS) The regional network consisting of all existing and proposed arterial and collector roadways.
- Low-density Residential Single family, mobile home, duplex, and townhouse developments.

M

- Main Street Corridor (ABC Comp Plan) Main Street Corridors are intended to be lively, highly walkable streets lined with local-serving businesses.
- Major Local Street Conveys traffic from other local streets to collector or arterial streets. The intent of major local streets is to provide sufficient space for 2 vehicles to travel unimpeded in opposite directions at the same time. Streets with an anticipated ADT of 1,000 vehicles per day or greater are classified as major local streets.
- Major Roads Roads classified as arterials or collectors.
- Major Transit Corridor Major Transit Corridors are anticipated to be served by high frequency and local transit (e.g. Rapid Ride, local, and commuter buses).
- Medians The center portion of the roadway that separates general purpose travel lanes moving in opposite directions.
- Mid-block Crossing A form of designated pedestrian crossing that is not located at an intersection.
- Mini Clear Sight Triangle A triangular area at all drivepads that should be clear of visual obstruction.

Mitigation Measures	Infrastructure that helps to moderate the effect of traffic generated by a development.
Motorcycle Parking	An area on street or in a private property with a sign delineating a motorcycle parking spot.
Multi-modal Corridor (ABC Comp Plan)	Multi-modal Corridors are intended to encourage the redevelopment of aging, auto-oriented commercial strip development to a more mixed-use, pedestrian-oriented environment that focuses heavily on providing safe, multi-modal transportation options.

N

Neighborhood Roadway Network	The local streets, often in a residential area, that are surrounded by the regional roadway network.
Neighborhood Traffic Circles	Small raised islands placed in intersections around which traffic circulates.
Normal Local Streets	Streets that direct traffic to major local streets or may connect directly to collectors and arterials. Streets with anticipated ADT from 250 to 1,000 vehicles per day are classified as normal local streets.

O

On-street Parking	Dedicated areas generally on the edge of the travel way and adjacent to the curb for vehicles to park.
-------------------	--

P

Parallel Curb Ramps	Curb ramp with running slopes that are in-line with the direction of sidewalk travel.
Parallel Parking	A vehicular parking area parallel to the road, in line with other parked vehicles
Park and Ride Facilities	Parking lots or formal station facilities that allow commuters and other transit users to leave their vehicles and transfer to public transit vehicles
Parking Islands	The ends of parking aisles that define parking stalls and provide adequate radii for vehicle turns and visibility.
Parklet	Also parquitos, Small public areas or commercial spaces supporting an adjacent business in which a curbside parking space is replaced with a seating area or gathering space that encourages additional activity along a street.
Paved Trails	also multi-use trails or shared-use trails, Are facilities that are dedicated for pedestrians and cyclists and are designed for use by people of all abilities for transportation and recreational purposes.

Pedestrian Access Route	An accessible corridor for pedestrian use within the pedestrian realm of the City right-of-way. The public access route is the path that provides continuous connection from the City right-of-way to building or property entry points, parking areas, public transportation, and/or other destinations. This route should be firm, stable, and slip-resistant and should comply with maximum cross slope requirements. The PAR should be at least 4 feet wide.
Pedestrian Realm	An area that includes the landscaping area and pedestrian access route (i.e. sidewalk, trail)
Permeable Pavement	A paving material that allows for infiltration of fluids.
Perpendicular Curb Ramps	A curb ramp that has a running slope that cuts through or is built up to the gutter grade break at right angles.
Premium Transit Corridor (ABC Comp Plan)	Premium Transit Corridors are intended to feature high-quality, high-capacity, high-frequency public transit (e.g. bus rapid transit).
Private school	A school established, conducted and primarily supported by a non-governmental entity in which instruction is offered by 1 or more teachers and is discernible as a building or group of buildings generally recognized as an elementary, middle, junior high or high school or any combination of those
Private Street	A street that is privately owned providing access to 8 or more dwelling units.
Private Ways	A street that is privately owned providing access to small subdivisions with 8 or fewer dwelling units.
Public School	As defined at § 22-1-2 NMSA 1978 a part of a public school district that is a single attendance center in which instruction is offered by 1 or more teachers and is discernible as a building or group of buildings generally recognized as either an elementary, middle, junior high or high school or any combination of those and includes a charter school.

Q

Queue Jump Facilities	Short transit-only facilities at intersections that are combined with signal prioritization to allow for buses to enter traffic flow ahead of general purpose travel lanes.
Queuing	A line of vehicles waiting as in a drive through facility.

R

Refuge Islands	Median refuges or pedestrian safety islands (referred hereafter as “refuge islands”) are protected spaces in the center of the roads, and may be located at signalized or unsignalized intersections or at mid-block crossings.
Regional Principal Arterial	Facilities where higher speed vehicle travel should be preserved and where access management strategies could be pursued.

Regional Roadway Network	The system of collector and arterial roadways (also referred to as major roads) that provide mobility and access across the city.
Reverse Angle Parking	also back-in angle parking, A parking configuration intended to improve the safety of on-street parking on bicycle routes.
Right-of-way	That area of land deeded, reserved or dedicated by plat or otherwise acquired by any unit of government for the purposes of movement of vehicles, bicycles, pedestrian traffic, and/or for conveyance of public utility services and drainage.
Road Diet	A range of techniques to encourage slower travel speeds and create space for pedestrian, bicycle, and transit users.
Roadway Reconstruction	Projects that include the construction of new curbs or the horizontal relocation of the curb line.
Roundabouts	A form of intersection control in which motorists (and cyclists) travel counter-clockwise around a center island and yield at entry points to traffic.
Running Slope	The slope measured parallel to the direction of travel.
S	
Separated Bicycle Lanes	also protected bicycle lanes or cycle tracks, Include some form of vertical element to separate the bicycle lane from automobile travel lanes.
Sharrow	A shared bicycle lane marking placed in the travel lane to indicate where vehicles and bicycles share a travel lane.
Shoulder	The space between the outside of the driving lane and the curb or roadway edge, and generally serve as a buffer, to provide space for disabled vehicles on high-speed roadways, and to provide space for maintenance and emergency vehicles
Sidewalks	A hard-surfaced walk or raised path and any curb ramps or blended transitions along and generally paralleling the side of the streets for pedestrians.
Signalized Intersection	Intersection locations where vehicles are managed through a traffic signal.
Signalized Pedestrian Crossing	A designated pedestrian crossing in which traffic is forced to stop and the pedestrian is protected via a traffic signal or pedestrian-activated signal device.
Slip Ramp	A curb ramp used to connect an on-street bicycle facility to an off-street bicycle facility.
Stopping Sight Distance	The length of roadway visible to the driver and sufficiently long enough to enable a vehicle traveling at or near the design speed to stop or change lanes before reaching a stationary object in its path.
Stub Street	The extension of a street past an intersection where a turnaround is not required.
Super-elevation	Vertical design of roadways where the outside edge of pavement is higher than the inside edge.

T

Traffic calming Devices	also speed management techniques, used to control motor vehicle speeds and discourage through-vehicle trips.
Traffic Impact Study (TIS)	An in-depth examination of the potential traffic impacts of new development on nearby roadways.
Traffic Scoping Form (TSF)	An overview of roadway and transportation conditions at proposed development.
Transit Station	Usually associated with a premium service such as Bus Rapid Transit, transit stations are distinguished from transit stops by having level-boarding platforms and passenger amenities such as ticket vending machines and real-time transit information, as well as common transit stop amenities such as seating, shelters, and/or leaning rails.
Travel Lane	Dedicated area for vehicle traffic.
Travel Way	Area that includes the curb-to-curb area used for vehicle and bicycle travel.
Trip Generation Analysis	Analysis of the vehicular trips generated for a proposed development.
Turn Lane	A dedicated space for vehicles to complete a turning movement without blocking the flow of traffic.
Two-way Left-turn Lane (TWTL)	A continuous center lane that allows motorists traveling in both directions to pull out of through lanes and into a shared lane for left turns.

U

Uncontrolled Pedestrian Crossing	A location where pedestrians may cross a roadway where vehicles are not controlled.
Unsignalized Intersections	An at-grade intersection in which the flow of traffic is not controlled by a traffic signal. Unsignalized intersections may be STOP-sign controlled, YIELD sign-controlled, or uncontrolled.
Urban Center	Urban Centers are walkable districts that incorporate a mix of employment, service, and residential uses at a density and intensity lower than Downtown but higher than neighborhood-serving Activity Centers.

W

Walkways	A passage or path for walking located on private property, which often connects the sidewalk to a building entrance or connects between different buildings on a site.
----------	--

