

CONCRETE PAVEMENT

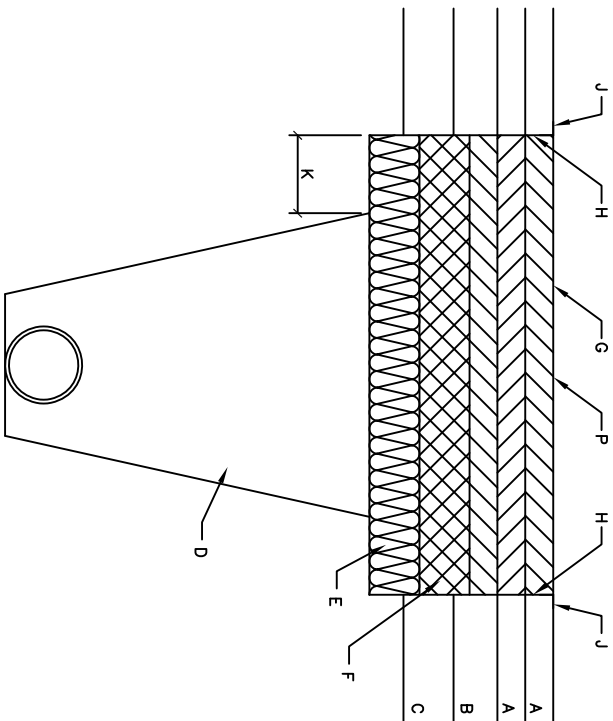

ASPHALT CONCRETE PAVEMENT

1. COMPACTION AS DETERMINED BY ASTM D1557 MAX DENSITY.
2. TRENCH CUT WIDTHS SHALL BE MIN. WIDTH REQ'D. FOR UTILITY INSTALLATION, ECONOMICAL BACKFILL COMPACTION AND COMPLIANCE WITH CURRENT AND APPLICABLE SAFETY REGULATIONS.
3. ALL PAVEMENTS CUT EDGES WILL BE TRIMMED TO PRESENT AN EVEN LINE PRIOR TO REPLACEMENT OF PAVING MATERIAL. "STITCH" CUTTING OF PAVEMENT WILL NOT BE PERMITTED. ADDITIONAL 2" THICKNESS OF ASPHALT CONC. REQ'D ON PAVEMENT CUTS LESS THAN 8' WIDE FOR ASPHALT CONC. PAVEMENT CUTS 8' OR MORE IN WIDTH AND LONGER THAN 100' SHALL BE PLACED WITH LAYDOWN MACHINE TO A DEPTH EQUAL TO THAT OF ASPHALT CONC. REMOVED.
- 4.

GENERAL NOTES:

CONSTRUCTION NOTES:

- A. EXISTING ASPHALT PAVEMENT.
- B. EXISTING BASE MATERIAL (ABC, BTB, CTB)
- C. EXISTING SUBGRADE
- D. COMPACTED FILL, 95% COMPACTION
- E. SUBGRADE TO MEET OR EXCEED APPARENT P-V VALUE OF ADJACENT SOIL, BY SOIL CLASSIFICATION (2 FEET MIN.).
- F. MATCH EXISTING BASE MATERIAL PLUS AN ADDITIONS 2" OF THICKNESS - 95% COMPACTION
- G. MATCH EXISTING ASPHALT CONCRETE SECTION PLUS AN ADDITIONAL 2" OF THICKNESS
 - a) FOR RESIDENTIAL STREETS, SURFACE COURSE SHALL BE 1 1/2" THICK, TYPE C
 - b) FOR MAJOR LOCAL STREETS, SURFACE COURSE SHALL BE 2" THICK, TYPE B
 - c) FOR ALL OTHER STREETS, SURFACE COURSE SHALL BE 2" THICK, S-III
- H. SAW CUT OR BLADE-CUT ASPHALT PAVEMENT. SAW CUT ONLY ONE THIRD CONC. DEPTH
- J. TACK COAT
- K. 12" CUT-BACK
- L. MATCH EXISTING CONCRETE PAVEMENT THICKNESS, 6" MINIMUM, 4000 PSI
- M. EXISTING CONCRETE PAVEMENT
- N. JOINTS TO BE TOOLED & SEALED IN ACCORDANCE WITH ENGINEERS REQUIREMENTS
- O. 6" CONC. TREATED BASE (CTB), OGFC OR PMSC REQUIRED IF OGFC OR PMSC EXISTS ON ADJACENT PAVEMENT
- P.

REVISIONS	CITY OF ALBUQUERQUE
10/2022	PAVING CITYWIDE PAVEMENT CUTS FOR ALL UTILITIES
DWG 2465	OCTOBER 2022