

**GENERAL NOTES:**

1. CROWN ON STREET SHALL BE AS FOLLOWS:
  - a. 32' STREET = 4"
  - b. 40' STREET = 5"
  - c. LESS THAN 32' STREET, PAVEMENT SLOPE = 2%
2. ALL SUBGRADE COMPACTION FOR C & G SHALL EXTEND 12" MIN ON EITHER SIDE OF C & G OR CURB SECTION.
3. SUBGRADE PREPARATION UNDER SIDEWALK AND DRIVE PADS SHALL BE INCLUDED WITH THE PARTICULAR ITEM.
4. FINISH GRADE AT PROPERTY LINE SHALL BE BASED ON A MIN 2% SLOPE FROM TOP OF CURB.
5. ALL ASPHALT CONCRETE (AC) PAVEMENT SHALL COMPLY WITH SECTION 116.
6. ALL PORTLAND CEMENT CONCRETE (PCC) PAVEMENT SHALL COMPLY WITH SECTION 101.
7. IN ACCORDANCE WITH COA DPM THE FOLLOWING APPLIES UNLESS AUTHORIZED OTHERWISE BY THE CITY ENGINEER:
  - \* RESIDENTIAL STREETS SERVING 50 LOTS OR LESS SHALL BE DESIGNED AS LOCAL RESIDENTIAL STREETS.
  - \* RESIDENTIAL STREETS SERVING MORE THAN 50 LOTS WITH AN ANTICIPATED AWDT < 3000 SHALL BE DESIGNED AS MAJOR LOCAL STREETS.
8. FOR SUBGRADE R-VALUE < 50, PAVEMENT SECTION SHALL BE DESIGNED IN ACCORDANCE WITH DPM CH. 7.
9. SUBGRADE PREPARATION SHALL BE PERFORMED AFTER ALL SUBSURFACE UTILITIES ARE CONSTRUCTED.

**CONSTRUCTION NOTES:**

- A. SIDEWALK AT STANDARD SETBACK.
- B. SIDEWALK ADJACENT TO CURB. (NON-STANDARD, VARIANCE REQUIRED).
- C. CURB AND GUTTER HEIGHT TO BE SPECIFIED ON PLANS
- D. ASPHALT CONCRETE (AC) OR PORTLAND CEMENT (PCC) PAVEMENT.
- E. 12" COMPACTED SUBGRADE PREP, 95% COMPACTION.

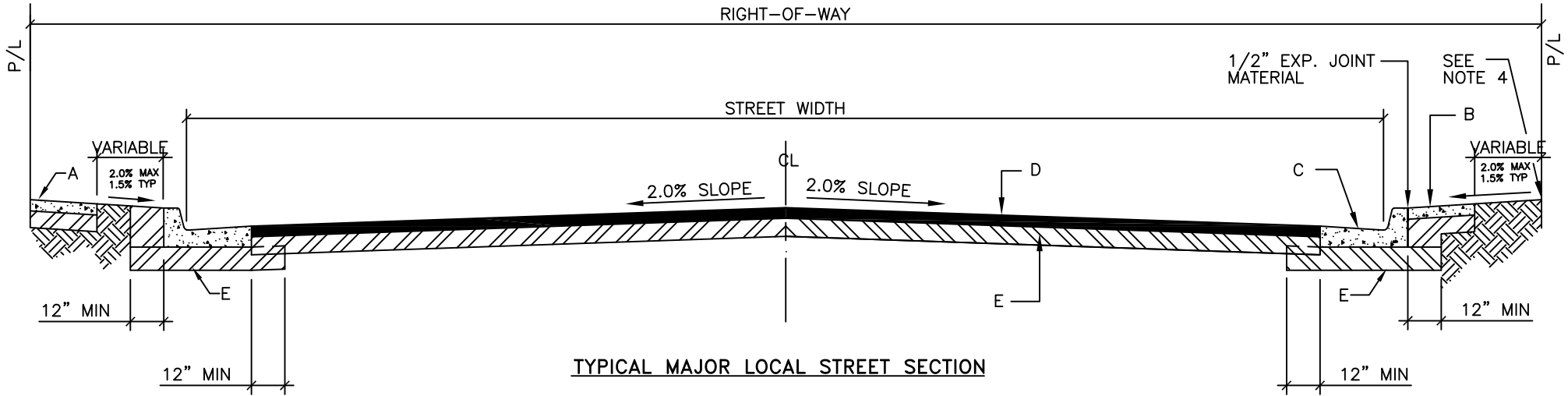

**TYPICAL MAJOR LOCAL STREET SECTION**

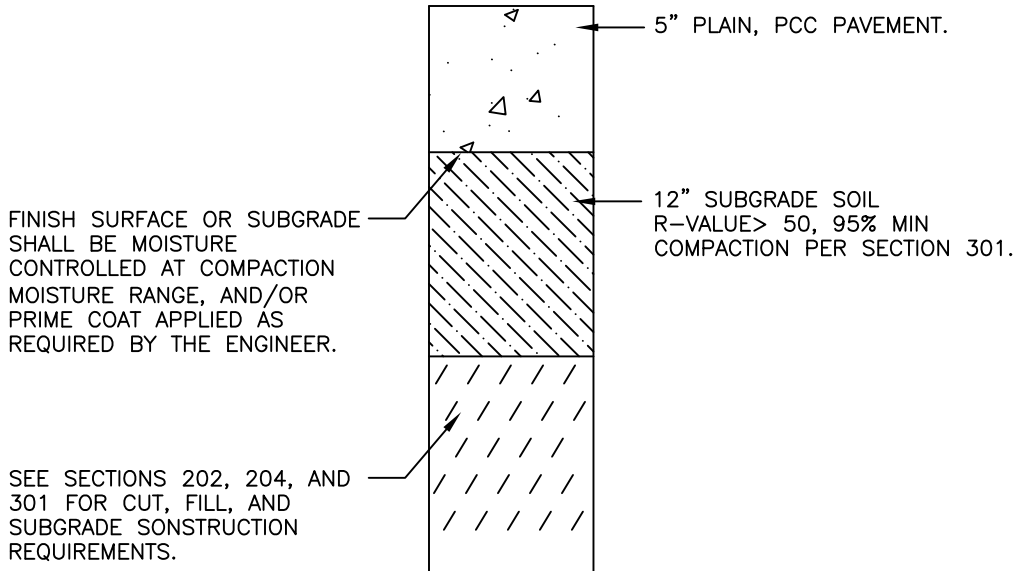

**RIGID PAVEMENT SECTION**

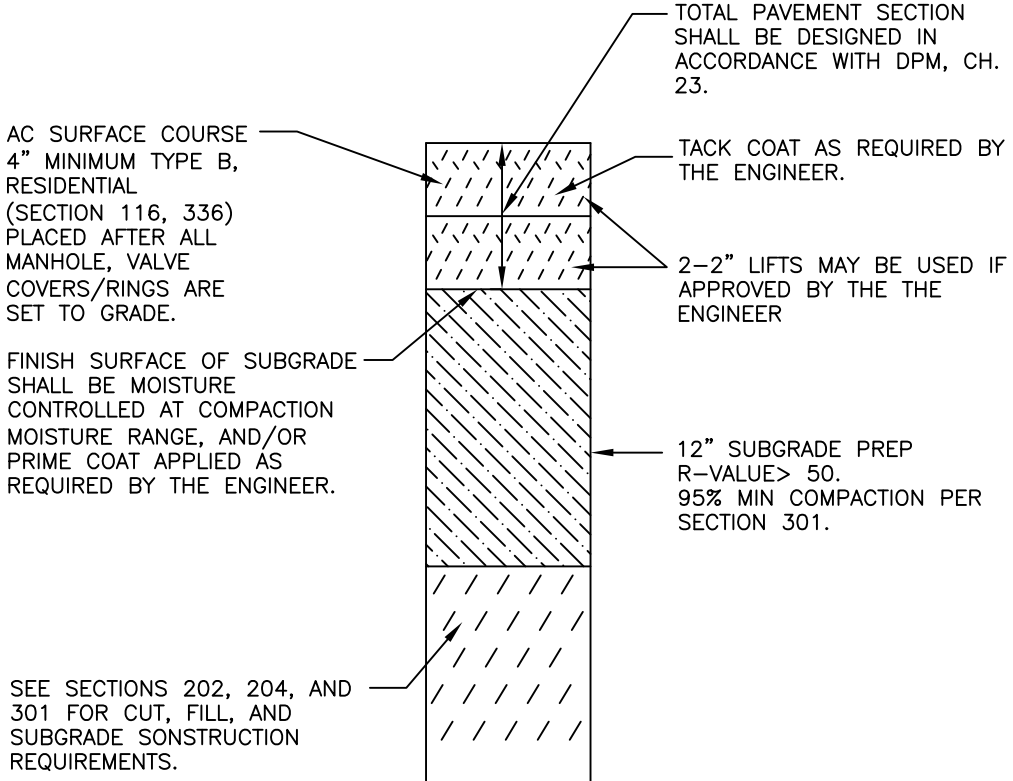

**FLEXIBLE PAVEMENT SECTION**

REVISIONS	CITY OF ALBUQUERQUE
10/2022	PAVING MAJOR LOCAL STREET SECTION DWG. 2405B      OCTOBER 2022